

SECTIONAL ELEVATION AA'

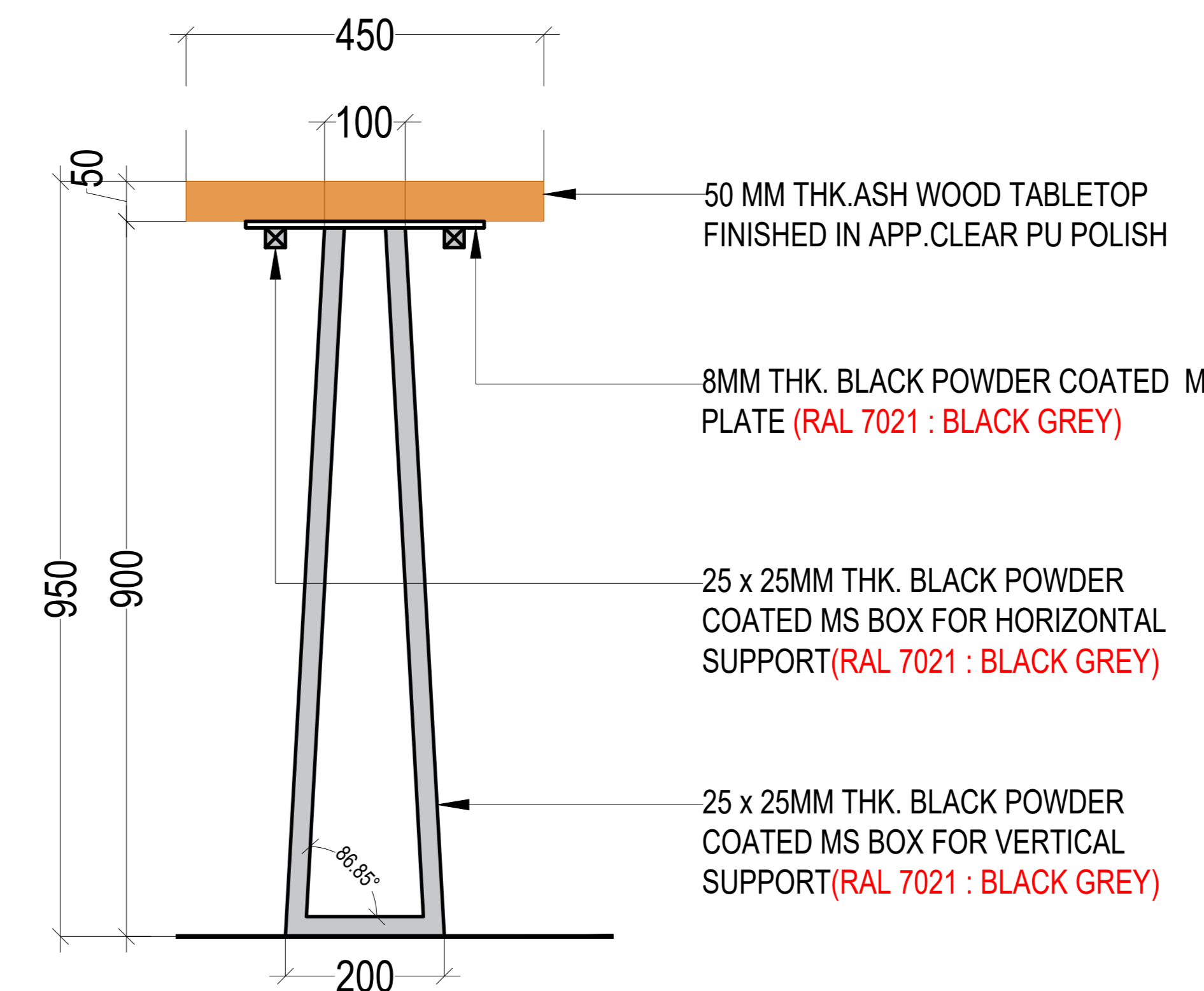

SIDE ELEVATION

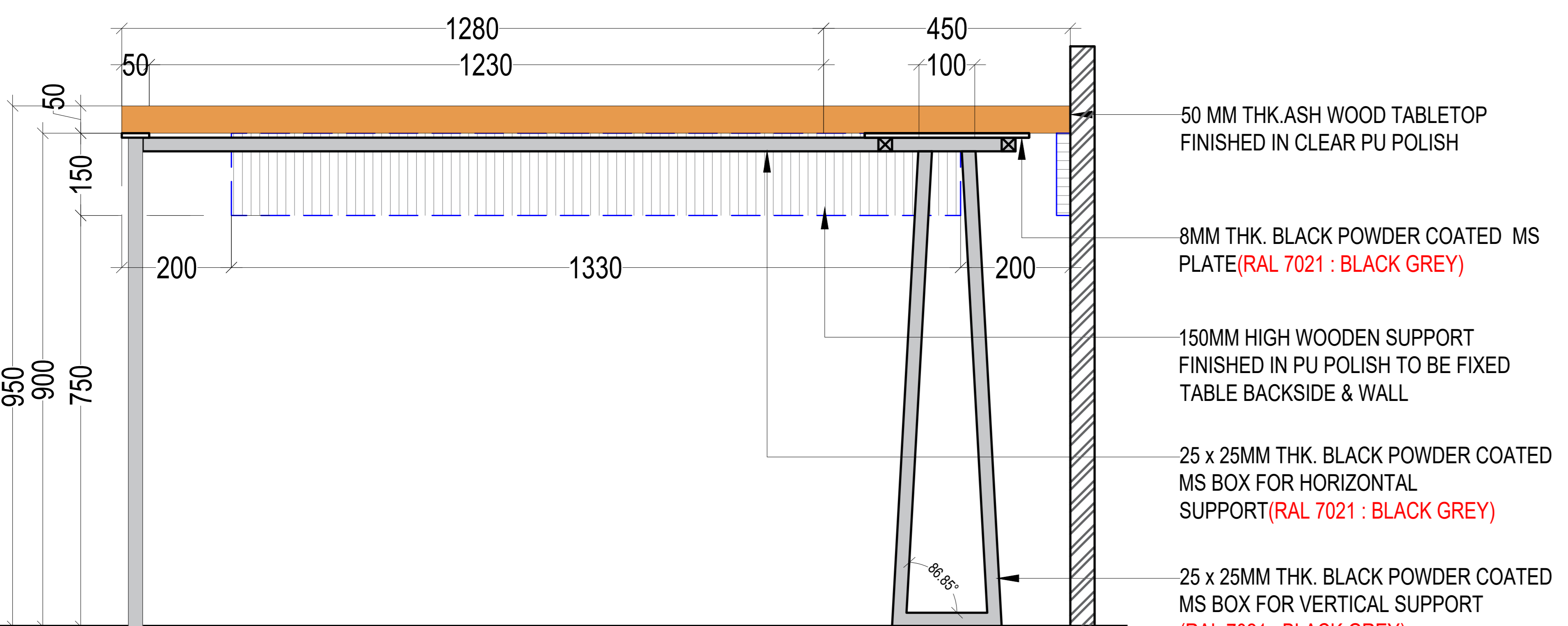

SECTIONAL ELEVATION BB'

"L" SHAPED 2-TOP HIGH TABLE
Counter height
Description:
Wood top with a powdercoated metal side leg. To be fixed to a divider or wall

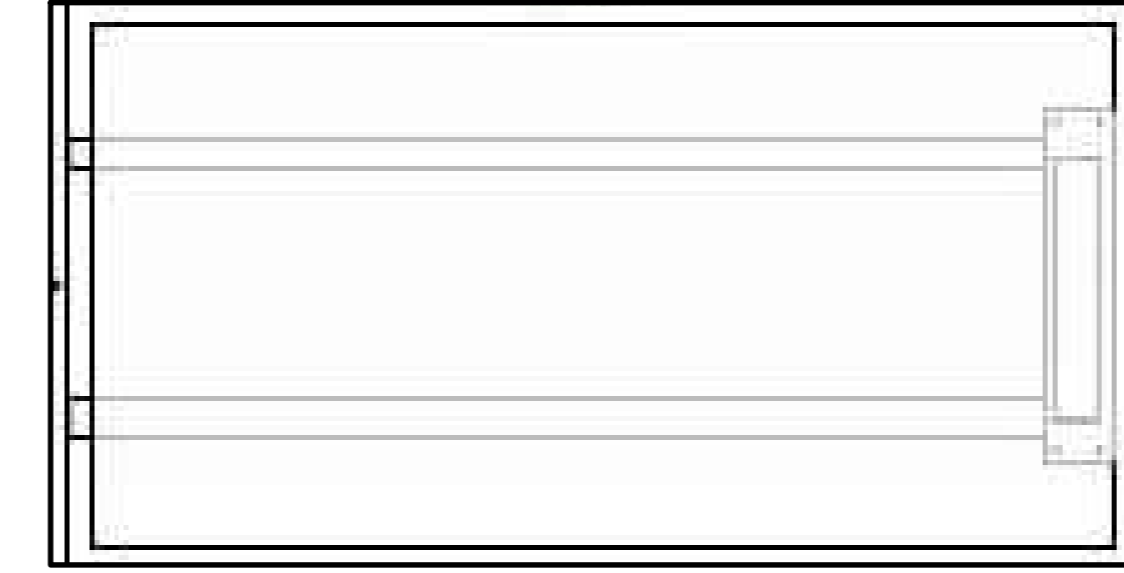
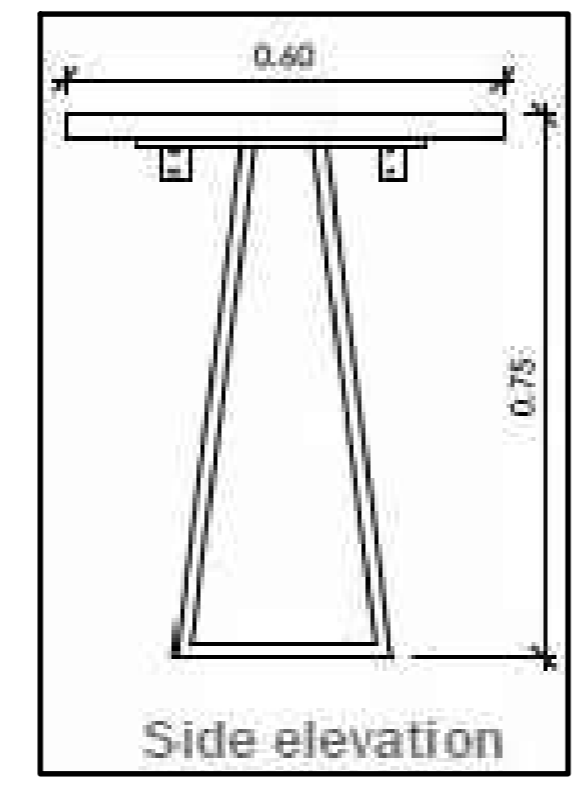

REFERENCE

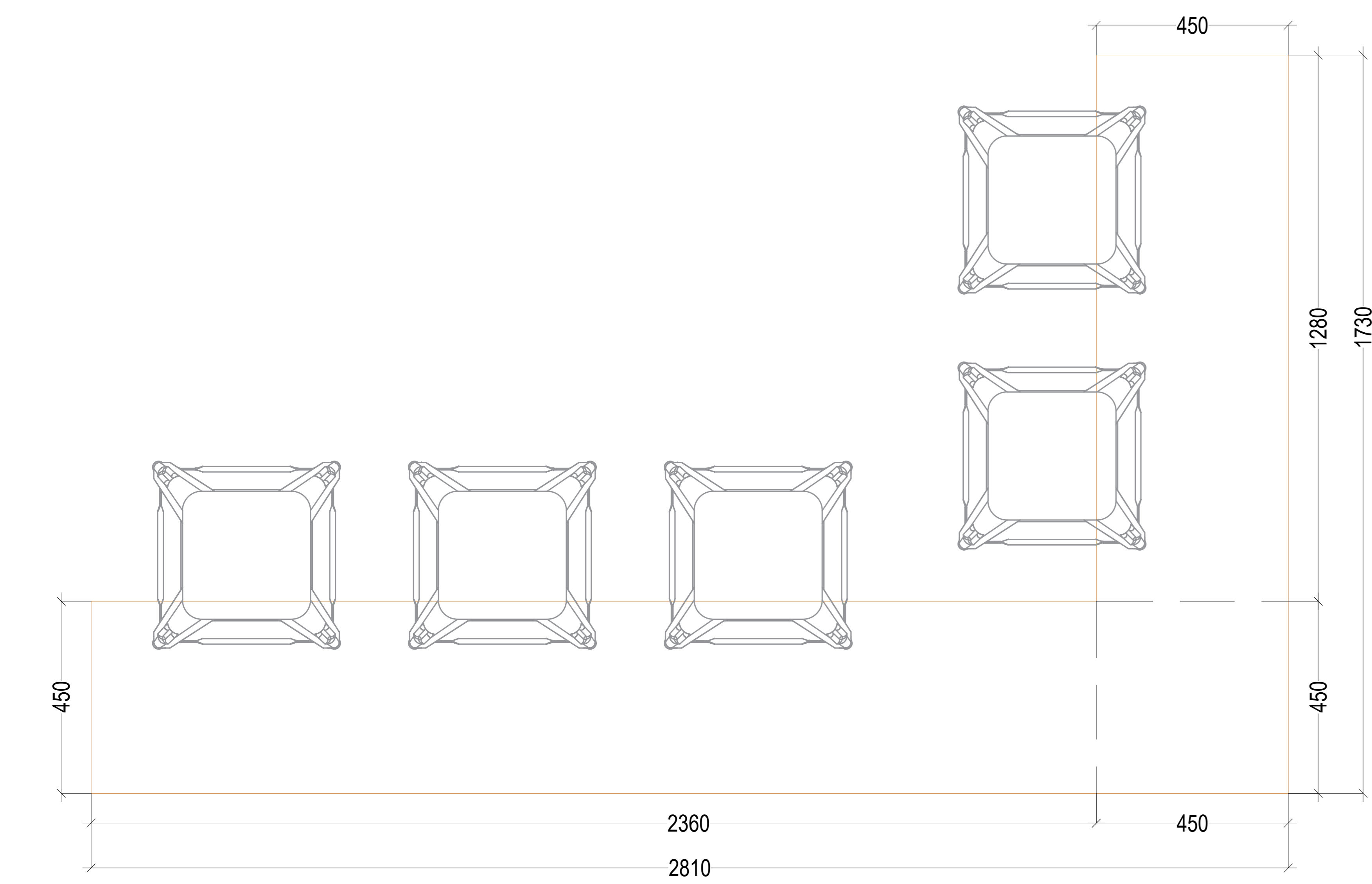

PLAN

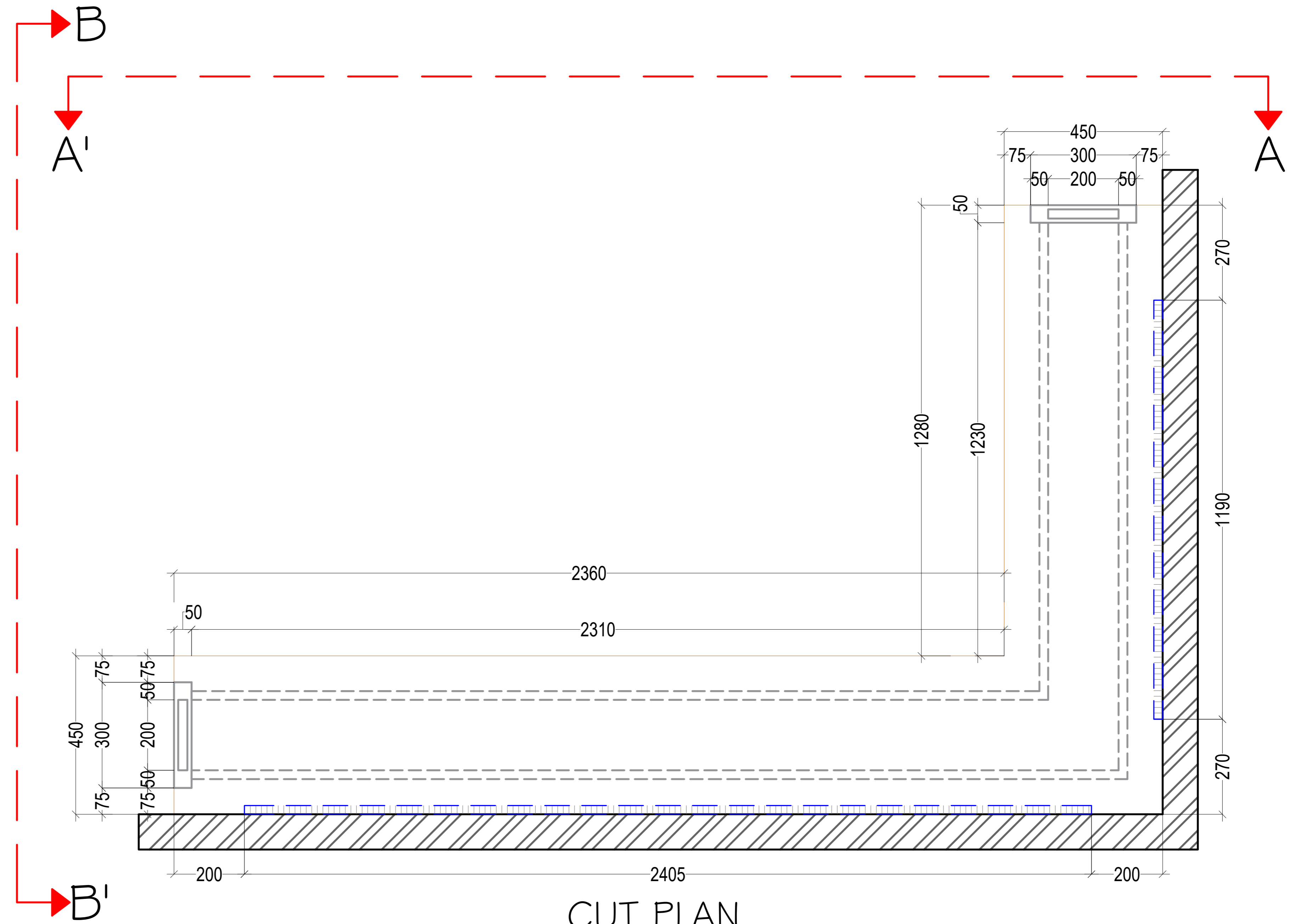

CUT PLAN

NOTES:
 • ALL DRAWING IS IN MM
 • THIS DRAWING IS A RIGHT & PROPERTY OF ARCHITECT NOT TO BE PRODUCED, COPIED, HANDED OVER TO THIRD PARTY OR USED FOR ANY OTHER PURPOSE OTHER THAN FOR WHICH IT IS INTENDED AND REMAIN OUR SOLE PROPERTY.
 • ONLY WRITTEN DIMENSIONS TO BE FOLLOWED.
 • THE CONTRACTOR MUST CHECK ALL DIMENSIONS & DETAILS & BE RESPONSIBLE FOR THE SAME ANY DISCREPANCY SHALL BE BROUGHT TO THE NOTICE OF THE ARCHITECT
 • THIS DRAWING SHOULD BE READ IN CONJUNCTION WITH RELEVANT WORKING & DETAILED DRAWINGS.
 • ALL DIMENSIONS SHALL BE VERIFIED ON SITE PRIOR TO START OF WORK

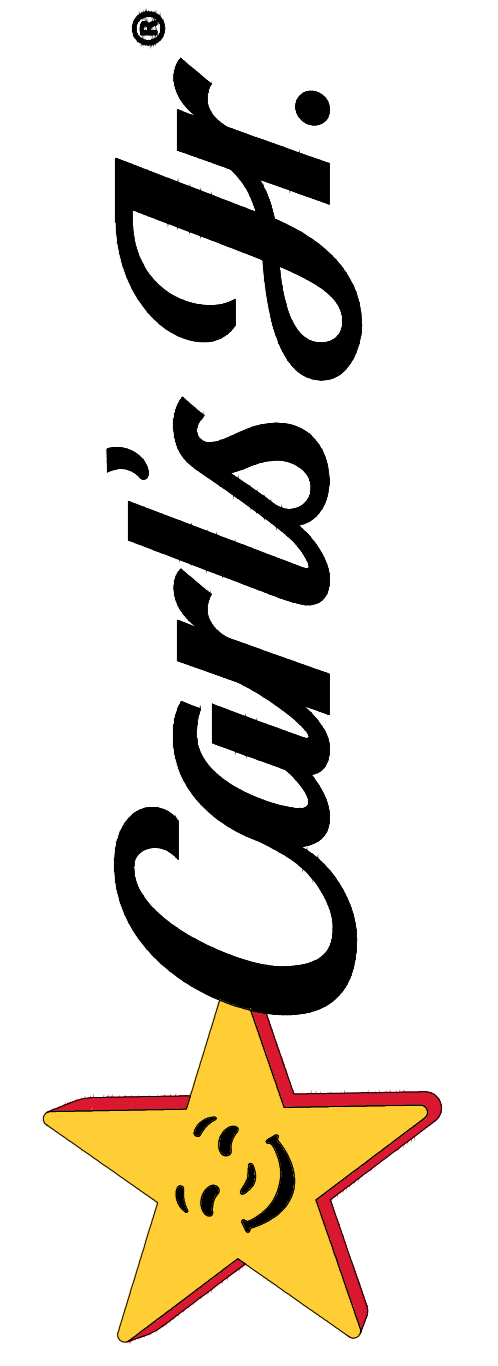

03			
02	15-01-2024	GFC DRAWING ISSUED	R1
01	30-12-2023	TENDER DRAWING ISSUED	R0
NO	DATE	DESCRIPTION	REMARK
		REVISION	

PROJECT TITLE
D-16A_CARL'S JR.

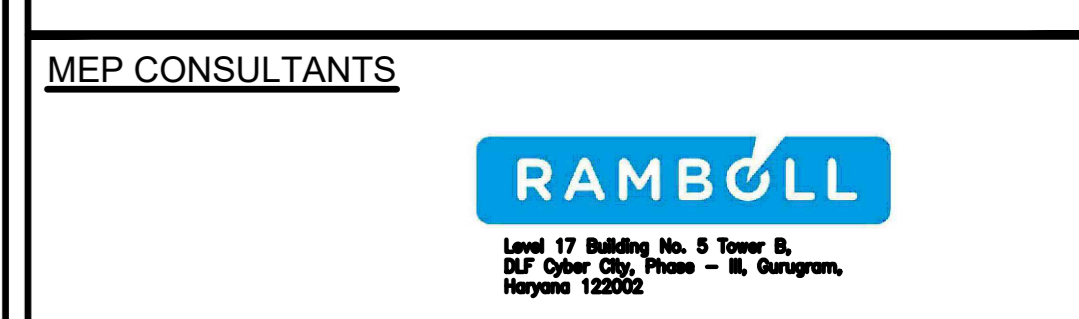

STRUCTURAL CONSULTANTS



SIGNATURE AND STAMP		COMMENTS
		TENDER
		SUBMISSION
		PRELIMINARY
		ADVANCE
		EXTRA COPY
		EXPLANATION
		APPROVAL
		EXECUTION

DRAWING TITLE
L-SHAPE TABLE DETAIL
CARL'S JR.

DATE : 30-12-2023	NORTH	REVISION
CHECKED BY : JINSHA		R0
DRAWN BY : FASAL		SCALE
SUPERCEDED Y/N		NTS
DRG. NO : LKO_DSHA_CARL'S JR._D-16A_GFC_R0_240116_23		