



COMMERCIAL KITCHEN DESIGNERS

TENDER DOCUMENT FOR MANUFACTURING, SUPPLY
COMMISSIONING & INSTALLATION OF KITCHEN EQUIPMENT

CLIENT NAME: TRAVEL FOOD SERVICES

PROJECT NAME: IRISH HOUSE

PROJECT LOCATION: HYDERABAD

CONSULTANT: - COMMERCIAL KITCHEN DESIGNERS

16, Kadambari, Devi Chowk, Shastri Nagar,

Dombivli (West) – Pin 421202.

Email – amit@commercialkitchendesginers.net



COMMERCIAL KITCHEN DESIGNERS

INSTRUCTIONS TO ALL BIDDERS

Preparation and Presentation of Bids:

All prices to be quoted to be in Indian Rupees & Foreign Currency wherever applicable. Cost should be inclusive of freight charges for imported bought out equipment, for custom fabricated equipment and local equipment. These freight costs should be shown separately.

Bids are to include price of each item, with a separate subtotal price for buy out equipment, delivery charges, and installation and performance bond. Any changes which come additional to this charge to this – which could be levies or taxes or any other form of duties, should be mentioned separately with each of the items and that the grand total price stated should include these details. Bids must strictly follow the item nos. mentioned against each equipment and should the vendor be awarded the order all equipment and parts shall carry the details on each piece to help the projects and technicians at site to identify the equipment and relate it to the Design Drawings.

The bid is to also state any deviations or an exception to any item and it acknowledges any addendum or change orders.

All fabricated equipment shall be manufacturer acceptable to **CLIENT**.

Site Storage:

No provision shall be made for the receipt or storage of any items delivered to the job site before the commencement of installation except as negotiated with **CLIENT**. All items must be received and accounted for by the Kitchen Equipment Contractor.

Errors and Omissions.

It is the responsibility of the bidder to report upon discovery during preparation of bid, any errors, ambiguity and omissions in drawings or specifications, at which time CKD will issue an addendum to all bidders. Unless expressly stipulated and in a timely manner, no additional allowances will be made for contractors or manufacturers for errors, omissions or ambiguities not reported at the time of bidding.

General and Specific Conditions:

All bidders shall submit the details in accordance to the General and Specific Conditions.

Commencement and Completion of Work:

Equipment shall be installed in accordance with the dates provided by **CLIENT**. The act of submitting a bid for the work of this project implies agreement by the bidder to confirm to this schedule.



COMMERCIAL KITCHEN DESIGNERS

Caution:

Each bidder is cautioned to carefully review all bid documents and become familiar with same. These documents will become a part of the **Kitchen Equipment Contract** and will be firmly followed throughout the bidding process and life of the project.

GENERAL CONDITIONS

A. Contract Documents:

Contract documents shall consist of: The specifications which consist of Instructions to bidders, General Conditions, Equipment Schedule, General Material Specification, General Manufacturing Guidelines, Equipment Layout drawing.

- 1) The drawings and specifications are said to be complimentary so that any work exhibited in the drawing and not mentioned in the specifications and vice versa is to be executed the same as if both were mentioned in the specification and exhibited in the drawings to the true intent and meaning of the said drawings and specifications when taken together.
- 2) Titles and headings to sections in this contracted document are introduced for convenience and shall not be taken as a correct or complete segregation of several units of material and labour. No responsibility either direct or implied will be assumed by CLIENT for errors or omissions by the Kitchen Equipment Contractor, due to real or alleged errors in arrangement or content of matter in the contract document.
- 3) The drawing and specifications are advisory and for information only. They are not intended to be, and shall not be used for construction purposes unless mutually agreed with CKD. They are to be used by licensed architects and Engineers for preparing stamped and sealed documents and for Kitchen equipment contractor for preparing dimensional roughing drawings, brochure and shop drawings.

B. The contract documents from the contract:

The contract represents the entire and integrated agreement between the parties hereto and supersedes all prior negotiations representations or agreements either written or oral including the bidding documents.

C. The Work:

The term work shall include all labour necessary to produce and install the equipment required by the Contract Documents.

II. Review of the Contract Documents.

Kitchen equipment contractor shall carefully compare and shall at once report to the owners any errors, ambiguities, inconsistencies or omissions that he may discover. Unless expressly stipulated and in a timely manner, Kitchen Equipment Contractor shall be directly liable to CLIENT for damages resulting from any such errors, inconsistencies or omissions arising out of any such errors. Kitchen equipment contractor shall not do any work without receiving written prior checking from CKD.



COMMERCIAL KITCHEN DESIGNERS

III. Assignment of Contract:

Kitchen Equipment Contractor shall not assign those contracts or any part thereof without written consent of CLIENT.

IV. Access Authority and Stoppage:

- 1) The work shall be available for inspection at any time by CLIENT & CKD.
- 2) All rejected work or material shall be immediately replaced by the Kitchen Equipment Contractor.
- 3) Work may be stopped by CKD & CLIENT if it is not being done in strict accordance with the specifications, or until any objectionable man or material is removed from the premises. The contract may be declared forfeited for non-performance when not being executed according to the meaning and execution of the contract, drawings and specifications.
- 4) Such stoppage, suspension or forfeiture shall not in any way invalidate any terms of the contract and no extra charge will be allowed to the Kitchen Equipment Contract by reason of such stoppage or suspension.
- 5) **Samples**
Submit samples of materials and parts of work requested by CKD & CLIENT for adequately judging the quality of work.
- 6) **Shop Drawings**
Submission of Shop drawings for each individual equipment is responsibility of KEC, the same will be checked and approved by CKD / CLIENT. the kitchen Contractor shall re-verify the actual site dimensions and conditions in compliance with requirements with specific conditions. The re checking of such drawings vis a vis the site shall not relieve the Kitchen Equipment Contractor from the responsibility of any deviations from the drawings and specifications unless such deviations are approved in writing by CKD.
- 7) **Emergency Repairs**
CLIENT reserves the right at all times to make emergency repairs without voiding or impairing guarantee or reliving Kitchen Equipment Contractor of responsibility during guarantee period. Any place of equipment producing objectionable noise and the equipment not being of set standards should be must be immediately, removed or repaired at the cost of the Kitchen Equipment Contractor.
- 8) **Supervision, Fabrication, Installation Procedures:**
Kitchen Equipment Contractor shall supervise and direct the work, using his best skill and attention. He shall be solely responsible for all construction means, methods, techniques and procedure for coordinating all portions of work, under contract and installation with the General Contractor so as not to interfere with or delay the overall construction of the project.
- 9) **Labour and Material**
Unless otherwise specially noted, Kitchen Equipment Contractor shall provide and pay for all labour, materials, equipment tools, transportation and other facilities and services necessary for proper execution and completion of work.



COMMERCIAL KITCHEN DESIGNERS

10) Delivery of Materials.

No provision shall be made for receipt or storage of any items delivered to the job site before commencement of installation except as negotiated with CLIENT. All items must be received and accounted for by the kitchen Equipment Contractor until acceptance by CLIENT.

11) Cutting and Fitting

Kitchen Equipment Contractor shall do all cutting and fitting on equipment for other sub-contractors to make their work fit, or as directed by CKD / CLIENT. No cutting, drilling or altering of any kind of activity to the building by the Kitchen Equipment Contractor without first obtaining an approval from the architectural representative shall be done.

12) Patching of Finish Surfaces:

Kitchen Equipment Contractor shall be responsible for all patching on the ceiling of the kitchen, floor or wall surfaces required by reason of his work and caused by negligence of his employees. Patches of any kind required will be repaired and charged by CLIENT to party causing damage.

13) A competent service representative of Kitchen Equipment Contractor shall be present when equipment installed is put into operation. He shall lubricate and put into proper operation all equipment and instruct CLIENT employees in proper use and maintenance of all items in contract.

14) Cleaning Up and Safety

The Kitchen Equipment Contractor shall keep his areas of responsibility clean and free from all debris and shall leave his area in finished condition. Should the Kitchen Equipment Contractor not clean up a place then CLIENT reserves the right to clean up the place and debit the same to the Kitchen Equipment Contractor. All norms pertaining to fire regulation shall be followed stringently by the Kitchen Equipment Contractor at the installation site.

SPECIFIC CONDITIONS

A. Works Included:

Furnished all labour, material and services necessary for installation of food service equipment in strict accordance with the specifications applicable drawings and local codes including that which is reasonably inferred:

- 1) The equipment shall be delivered and installed on schedule. The Kitchen Equipment Contractor shall be responsible for coordinating the work with the General Contractor.
- 2) Field dimensions before fabrication.
- 3) Indirect waste piping to floor sinks.
- 4) Cutting of holes in equipment for pipe, drains, electric outlets etc. as required for this installation. Work shall conform to the highest standards of workmanship.
- 5) All work involved in making stands and support for all equipment requiring them.
- 6) Repair of all damage to the premises as a result of this installation and daily removal of all debris left from the Kitchen Equipment Contractor from site at his expenses.
- 7) Food service and equipment and fixtures shall be cleaned and ready for operation at the time the site is turned over to CLIENT.



COMMERCIAL KITCHEN DESIGNERS

B. DRAWINGS

The drawings, which constitute a part of the contract, indicate the arrangement and location of equipment. Should it be necessary to deviate from this arrangement in order to meet structural conditions, such deviations shall be made without expense to CLIENT.

- 1) The data given herein on the drawings is reasonably exact, but extreme accuracy is not guaranteed. Drawings and specifications are for the assistance of the Kitchen Equipment Contractor and the exact locations and distances and levels will be governed by the building. Kitchen Equipment Contractor shall accept his contract with this understanding.
- 2) The Kitchen Equipment Contractor shall check at site all the existing civil and utility services and shall provide all equipment to suit building conditions and utilities. No extra charges shall be allowed for utility changes to fit equipment during installation and connection.

C. REGULATIONS

- 1) Work materials shall be in full accord with latest rules and or regulations of agencies / authorities having jurisdiction.
- 2) Regulation, including building codes, steam codes, gas codes and other codes applying to this jurisdiction.
- 3) Electrically operated equipment, fabricated or otherwise shall conform to the norms of the latest national and electric codes.
- 4) Steam heated equipment shall be manufactured in accordance with all national and local codes governing steam equipment.
- 5) Gas fired equipment shall also conform to all rules as laid down by the local / national bodies.
- 6) When seismic rules are applicable the equipment shall be installed in accordance with those regulations.
- 7) Ruling and interpretation of the various governing bodies shall be considered a part of the regulations.

D. ELECTRICAL WORK

- 1) The Kitchen Equipment Contractor shall for all fabricated equipment, furnish and install, all outlets, switches, controls, conduits, service fittings and panel boards on equipment wherever necessary.
- 2) All electrical equipment to have the local approval and to be in accordance with job requirement at site.
- 3) All conduit wiring shall be concealed wherever possible. Conduits shall be continuous from outlet to outlet to panels and the panels to the outlet.
- 4) The Kitchen Equipment Contractor shall supply on each motor driven appliance or electrical equipment and a suitable control switch or starter of proper type which should be in accordance to the local rules and regulations.
- 5) All switches, controls, shall be conspicuously labelled as to use with name plates screwed to the adjacent surfaces.
- 6) All electrically heated, fabricated equipment shall be internally wired to a thermostatic control and an "on/off" red neon light indicator, both to be mounted in the terminal box with a removable access panel and located outside the heated panel. Wiring to be heat resistance Teflon coated properly insulated.



COMMERCIAL KITCHEN DESIGNERS

E. VENTILATION WORK

- 1) Provide all labour, material and services required, verify sizes and location of duct connections and provide all exposed duct work from the hoods, ventilators, dish washers to building duct within the room
- 2) All Exhaust hoods to be provided with Bulk Head lights with Teflon coated heat resistance wiring.
- 3) Hoods will have oil drip trays for collection of grease.

F. PANS and INSERTS

All equipment's unless specifically specified shall be rated to receive all Gastro norm pans.

G. PLUMBING WORK

- 1) Provide suitable pipe slots, chases and or /do all drilling, punching and cutting of equipment required to provide access for mechanical connections and or runs. Such work performed at the job site shall be of same quality as similar work in the shop.
- 2) Kitchen Equipment Contractor to provide all taps and wastes as required for sinks and related plumbing requirements. Taps make and design to be confirmed with CKD / CLIENT.
- 3) Indirect waste piping to floor sinks. Indirect waste from the ice bins or the ice pans or similar items shall be insulated to prevent condensation.
- 4) All pipes shall have pipe threads.

H. START UP AND DEMONSTRATION

Kitchen Equipment Contractor shall provide service representative to be present when installation is put into operation and to remain on the premises for a minimum of 7 days after the entire space is put into operational use. The Kitchen Equipment Contractor shall also provide a maintenance schedule to CLIENT.



COMMERCIAL KITCHEN DESIGNERS

GENERAL MANUFACTURING GUIDELINES

Stainless Steel

- Where Stainless Steel is specified, it shall conform to the trade name austenitic 18 – 8 type 304, be finished with chrome content ranging from 17% to 19% nickel, 7% to 9% maximum carbon content of 0.11%.
- Stainless Steel shall be free from scale and all surfaces shall be polished to No. 4 commercial finish

WELDING

- All welding shall be done in a thorough manner, with welding rod of the same composition as sheet or parts welded. All welding should be of Argon Arc type and they shall be complete welds, strong and ductile, with excess metal ground off and joints finished smooth to match adjoining surfaces, Welds shall be free of mechanical imperfections such as gas holes, pits, runs, cracks, etc, and shall have same colour as adjoining surface. All joints in tops of fixtures, tables, drain-boards, exposed shelving, sinks etc. shall be Argon Arc welded. All equipment's herein specified which is constructed of more than 1 (one) piece or sheet of metal, shall be continuously butt – welded together, with welds ground smooth and polished.
- All welded joints shall be homogeneous with the sheet metal itself. Where sheet size necessitates a joint, such joints shall be welded. Tops of fixtures shall be fabricated in the factory with welded joints to reduce field joints to minimum.
-
- Where fixtures join, tops of such fixtures shall be continuous with welded joints, except in the case of field joints. Joints made in the field shall be closely butted, pulled together in field, field welded, ground and polished smooth in accordance with specification. Top of fixture shall be of maximum length with welded factory joints to permit bringing of the fixtures to their final position in order to reduce field joints to absolute minimum. Wherever welds occur on surface not finished by grinding and polishing, such welds and accompanying discoloration shall be suitably coated in the factory by means of a metallic basic paint over two coats of red – oxide to prevent the possibility of progressive corrosion of such joints.
- All welding must be so done as to avoid any inflammation and bending of sheets as per possible and should have this factored in being carried out on the shop floor.
- When legs are being welded to shelves proper jigs should be used to ensure no undue bending of the last part of the legs, which shall not be acceptable under any circumstances.



COMMERCIAL KITCHEN DESIGNERS

SOLDERING AND BRAZING.

- Soldering where required shall be done with solder consisting of 75 percent pure tin and 25 percent lead. Stainless steel requiring soldering shall be first thoroughly cleaned of surface oxides and shall then be treated with suitable stainless steel soldering flux shall be passively cleaned and the entire soldered joint cleaned with liquid alkaline or a neutralizing reagent to prevent any attack on stainless steel by the soldering flux.
- Particular and special care shall be given to neutralizing of all excess soldering flux in no case shall soldering be relied upon for stability of seams or joints. Soldering shall serve only as a filter to prevent leakage. Soldering shall not at any time be used in or on containers or food handling equipment coming in contact with foods.
- Brazing shall not apply to joining of brass or copper pipe and tubing to brass and bronze connecting fittings, particularly in the case of steam coils. All steam coils requiring dip tinning shall be first brazed with surplus flux removed so that the metal is exposed and then dipped. Low temperature melting silver base hard solder will be considered the equivalent of brazing.
- Brazing or hard silver solder shall not in any event replace a welding operation and no stainless steel to stainless steel joints are to be made by brazing or hard silver soldering.

Grinding, Polishing, Finishing.

- All welded exposed joints shall be suitably flush with the adjoining material and nearly finished to harmonize therewith. Where material has been sunken or depressed by welding operation such depressions, shall be suitably hammered and preened flush to adjoining surface, and if necessary, again ground to eliminate low spots. All ground surfaces shall then be polished or buffed to match the adjoining surfaces, consistent with good workmanship. Care shall be exercised in all grinding, operations to avoid excessive heating and metal discoloration. In all cases grain of rough grinding shall be removed by successive polishing operations. Texture of final polishing operations shall be uniform and smooth, consistent with reasonable care and good workmanship. General finish of all equipment shall be of a high-grade MATT FINISH (satin finish using imported buffs)
- Butt joints and contact joints, wherever they occur, shall be close fitting and shall not require solder as filler. In no case is any soldering operations to be done where dependence is placed solely on soldering for strength and stability or joint or fixture itself. Wherever breached bends occur, they shall be free of undue exudence and where such break – work does mar uniform appearance of material all such marks shall be removed by suitable grinding, polishing and finishing. Wherever sheared edges occur, they shall be free of burns. Fins or irregular projections and shall be finished over such sheared edges. Where mitres or bull nosed corners occur, they shall be neatly ground to uniform condition. In no case overlapping materials will be acceptable.
- At all times emphasis will be placed on production of equipment of quality finish, consistent with high grade manufacturing practices.



COMMERCIAL KITCHEN DESIGNERS

- All exposed surfaces shall be duly buffed and polished.

Handles, Brackets, Locking Devices and Hardware

- Wherever equipment is provided with handles, knobs, hinges, brackets or other miscellaneous hardware, all shall be of either heavy satin finish chrome plated brass or stainless steel or of metallurgical composition specified. These and such other items that may be required to be provided by the kitchen equipment manufacturer they shall be of uniform type, quality, shape etc. and shall be approved by the Owner/ Consultant.
- All drawers enclosed cabinets, refrigerators, storage bins shall be furnished with extra heavy duty, security type of cylindrical locking devices which shall be chrome plated. All devices shall be approved prior to installations.

Sound Deadening

- Underside of all stainless-steel tops for tables, counters, sinks, dish and pot tables with angle frame work shall be treated with a coating of “**Carbonized**” aluminium finish or approved equivalent paint.

Protection Against Corrosion

- Wherever a welding operation occurs on stainless steel the possibility of corrosion must be entirely eliminated. Bolts and screws may be welded by an accepted process that will eliminate the possibility of carbide precipitation. Each joints of welding shall be carefully finished to eliminate the possibility of progressive corrosion. The underside of each weld should be suitably ground or coated to prevent the possibility of oxidation and progressive corrosion. Welding done by any process, which eliminates or reduce carbide precipitation in connection with bolts and screws, need not be so treated. All welded joints shall be suitably treated to prevent or eliminate the possibility of corrosion. Welds done to holds tops with under frame work s shall be only of tack weld type and not continuous welding type.

Bolt Construction:

Wherever possible all equipment should be free of bolts, screws and rivet heads, wherever bolts are used to fasten trim to panelling or body warmers, cabinets, counters, etc and more particularly to fasten tops of counters, dish – tables, etc. to top framing, such bolts and screws shall be of the concealed type. Wherever threads of bolts and screws occur on inside of fixtures and are either visible or might come in contact with hands or wiping cloth, such bolts and screw threads shall be capped with a suitable lock washer and acorn nut. Also, the screw heads wherever visible must be of star screw type – so that the same can be counter sunk type of installation. Where screw threads are not visible or readily accessible, they may be capped with a standard lock washer and steel nut treated to prevent rusting or corroding. Wherever bolts are screws are welded to the underside of trim or tops, the reverse side of the weld shall be neatly finished, uniform with adjoining surface of trim or top. Depressions at these points shall not be acceptable



COMMERCIAL KITCHEN DESIGNERS

Material and Workmanship

All materials, equipment etc. shall be new and of the type specified and shall be in undamaged condition when handed over to the Owner. All workmanship shall be of best quality by craftsman skilled in their respective trades. Appliances shall be of rigid construction, free from objectionable vibrations and quiet in operation.



COMMERCIAL KITCHEN DESIGNERS

GENERAL MATERIAL SPECIFICATIONS FOR KITCHEN EQUIPMENTS

TOPS

Made of 16 SWG 304 Quality 18/8 Grade Stainless Steel duly 120 Grit matt polished with all resulting edges rounded with no bur or other excess material left. Top will be turned down 2" and 1/2" underneath in channel shape on all exposed sides, in case of sunk in tops wherever mentioned the sides shall be raised by 3/4" on all exposed sides, where tables are placed against building walls, they will be turned up at back 6" returned 1" at 45 degree to wall with all exposed ends closed, argon arc welded and smooth polish.

UNDERSIDES

Undersides of all Stainless-Steel Tops for Table Counters will be mounted on 32 x 32 x 3 mm Stainless Steel Angle (*202 Quality*) frame work with cross angles of maximum of 30" from centre to centre, duly secured with welding.

UNDERSHELVES

Under shelves wherever called for will be constructed of 18 SWG 304 Quality 18/8 Grade Stainless Steel Sheeting uniformly matt polished with 120 grit and reinforced with 32 x 32 x 3 mm Stainless Steel angle frame (*202 Quality*). All Shelves will be turned down 1 1/2" and 1/2" underneath on all sides with resulting corners cut out to fit contour of legs. Shelves for Hot case will be perforated shelves.

LEGS/UPRIGHTS

All legs/uprights will be constructed of 1 1/2" Dia. Stainless Steel tubes / 32x 32 MM Square Pipe of 16 SWG 304 Quality, spaced not more than six feet on centre. All legs will be fitted with Ferro 1000 nylon adjustable 1 1/2" bullet feet. Units more than 1800 mm in length will have 3 pairs of uprights.

CROSS BRACINGS

Front to back forming a 'H' frame where required will be constructed of 1" dia. Stainless Steel tubes of 16 SWG 304 Quality. All cross bracings will run horizontal and level between all legs approximately 6" above floor level. All joints will be completely welded around entire perimeter forming complete seal, with all welds ground and polished to match adjacent work.



COMMERCIAL KITCHEN DESIGNERS

SINK

All sinks will be constructed of 16 SWG, 304 quality Stainless Steel with radius corners, argon arc welded, smooth ground and uniformly finished, duly fitted with 1 ½” dia. BSP drain coupling and 1 ½” Dia ball valve and /OR faucet as mentioned in individual input listing (Do not make Faucet Hole on the unit without the sample of plumbing fitting).

STAINLESS STEEL STORAGE RACK

Shelves will be made of 18 SWG 304 Quality 18/8 Grade Stainless Steel Sheeting. Each rack will have number of shelves as specified in the description and reinforced with 1”x3”x1” inverted 16 SWG Stainless Steel Channel. Uprights of 1 ½" Dia 16 SWG Stainless Steel pipes 304 Quality fitted with Nylon bullet feet.

BAIN MARIE WATER CHAMBER

Made from 18 SWG, 304 quality Stainless Steel, argon arc welded fitted with 1”dia. Lever operated drain valve for easy drain out and provided with cavity to house water immersion heater for efficient heating & duly insulated with 1” thick glass wool.

INTERIOR OF HOT CABINET / PLATE WARMER

All interior of Hot Cabinets and Plate Warmers will be constructed of 18 SWG 304 Quality 18/8 Grade Stainless Steel beaded panels duly insulated with 2” thick glass wool insulation with thermostatic control from 0 – 110 degree C. Thermostat is of EGO make (Germany). The Control panel die pressed & flushed with the front.

SLIDING DOORS

Wherever provided to cabinets as non-insulated will be constructed of 18 SWG 304 Quality 18/8 Grade Stainless Steel beaded panels and as insulated door will be constructed of 19 SWG 304 Quality 18/8 Grade Stainless Steel beaded panels duly mounted on top hung easy rolling nylon rollers and Stainless Steel guiding rails below.

BLINDER / ENCLOSURES

Made of 20 SWG 304 Quality 18/8 Grade Stainless Steel Sheeting uniformly polished and duly beaded from all sides.



COMMERCIAL KITCHEN DESIGNERS

OVERHEAD SHELVES

Wherever provided will be made of 18 SWG 304 Quality 18/8 Grade Stainless Steel double beaded on all sides duly reinforced and fixed on 1" Dia., 16 SWG Stainless Steel tubular pipes at the height as reinforced with 1"x3"x1" 16 SWG Stainless Steel Channels.

WALL SHELVES

Made of 18 SWG 304 Quality 18/8 Grade Stainless Steel Sheeting with 1 1/2" wall 3 sides and double beaded downwards at front duly secured with 16 SWG 304 Quality 18/8 Grade Stainless Steel Wall Bracket.

WALL STORAGE CABINET

Constructed of 18 SWG 304 Quality 18/8 Grade Stainless Steel hinged doors wherever mentioned not exceeding 15" length. Doors shall be provided with pad lock facility. Heavy duty angle shall be mounted below the cabinet, and shall be fixed on wall with Anchor Bolts.

FRONT / CONTROL PANELS

All equipment will have the front panel made of 18 SWG 304 Quality 18/8 Grade Stainless Steel duly beaded and die pressed for safety operations.

POT RACK

Made of 1 1/2" Dia. Stainless Steel pipes 304 Quality 18/8 Grade for uprights and 3/4" Dia. Stainless Steel pipes for shelves. The unit will be fitted with adjustable Bullet legs Ferro Nylon Make.

ELECTRICALS

All electrically operated equipment's will be thermostatically controlled with indicating bulbs duly fitted with best quality branded heaters and heat resistant Teflon coated copper wire.



COMMERCIAL KITCHEN DESIGNERS

GAS EQUIPMENTS

All gas equipment's will be duly connected with best quality copper pig tails, needle valves and burners will be off heavy-duty industrial type and to be operated at 4.5 PSI gas pressure. Gas inlet will be on both sides towards back of the equipment.

REFRIGERATED EQUIPMENTS

All cold or refrigerated equipment's will have inner camber made out of Stainless Steel 21 SWG sheet of 304 quality. It will have radius bending inside for hygiene and easy cleaning. Outer body made out of Stainless-Steel Sheet of 18 SWG of 304 quality. Doors will have pad lock facility. Each Chamber will be provided with SS racks.

COMPRESSORS

All compressors for cold units will be of Kirloskar make only. Other accessories of reputed make.

INSULATIONS

All equipment's will be suitably insulated with 1" Thick high quality mineral glass wool/asbestos. Oven will be insulated with 3" thick glass wool. Cold or Refrigerated equipment's will have insulation of P.U.F (Poly Urethane Foam) 2" thick.

MARBLE TOPS

Wherever called for will be of ¾" thick white marble duly places on ¾" thick marine ply and framed with 16 SWG Stainless Steel all sides to prevent slipping with neoprene rubber shock absorbent strips.

COUNTER/TABLES TOP:

Single top Counter/Tables required, wherever specified. KEC to check the feasibility in terms of entry of the equipment into the site. If KEC feels that getting required equipment at site in one piece, they need to inform the consultant and divide accordingly with provision of welding at site.



COMMERCIAL KITCHEN DESIGNERS

GENERAL CONDITION FOR MODULAR EQUIPMENT

The bidder shall study the specifications before preparing their bids and shall clearly indicate any changes or deviations from those given in the documents in their jobs. Deviations should be shown in a tabular form clearly indicating item wise deviation alongside original specifications so these may be considered during evaluation of the bid.

The bidders are required to quote on the following basis:

- Ex- factory / work basis.
- Packing & forwarding.
- Loading/ unloading at ports and at Project Site.
- Transportation from works to site.
- All applicable taxes and duties.
- Installation cost with details.

01. Kitchen Equipment contractor (K.E.C.) shall ask the owner in writing within one week of receiving tender documents-for any clarifications and shall promptly bring to the owner's attention any discrepancy, duplication or omission that may come to his notice.

02. A. K.E.C. shall furnish total price installed, with break-up of prices giving F.O.B. (U.S.\$) rates and onwards, including cost of sea-worthy packing/containerization, sea-freight, insurance, import duty, octroi (if applicable), customs clearance charges, work contract tax, C.S.T., service charge and any other costs etc.

B. K.E.C. should confirm that all equipment quoted would carry manufacturer's warranty of 12 months from the date of complete handing over.

C. It shall be the responsibility of the K.E.C. for complete work including supply, assembly, and installation, commissioning, testing & handing over to clients.



COMMERCIAL KITCHEN DESIGNERS

SPECIAL CONDITIONS FOR MODULAR KITCHEN EQUIPMENT

KITCHEN EQUIPMENT CONTRACTORS (K.E.C.).

- Shall ask the owner in writing within two weeks of receiving tender documents for any clarifications and shall promptly bring to the owner's attention any discrepancy, duplication or omission that may come to his notice.
- K.E.C. shall furnish separate prices- ex- factory for each & every piece of equipment and indicate the cost of local freight separately or shall indicate F.O.B prices for each item.
- K.E.C. shall indicate separately the cost of sea worthy packing / containerization and the estimated cost of inland transportation, Sea freight and import duties as applicable.
- K.E.C. shall indicate separately for each item or a lump sum cost, for installation, testing & commissioning. Connection of all utilities will be done by other agencies as per the utilities plan to be submitted by K.E.C. within 3 weeks of placing orders.
- K.E.C. should confirm that all equipment quoted will carry manufacturers' warranty of 12 months from the date of commissioning & handing over.
- K.E.C. should base the quotation keeping in view the following terms of payment and should indicate any other terms of payment at the same time indicating the percentage impact on the basic prices quoted as per the stipulated terms of payment.
- The K.E.C. shall study all the drawings and specifications and shall clearly indicate any change or deviation in his bid from those given in the drawings and specifications, so that they can be taken into consideration at the time of making comparison of prices.
- For any deviations in the Make & Model Nos., the K.E.C. shall indicate the compatibility of the production capacity, thermal rating of insulation, consumption of utilities i.e. electricity water, steam etc. and the power rating of the motor, pumps, heaters, burners etc.
- K.E.C. shall submit two (2) sets of catalogue cut in original of all equipment quoted. The item no. and quantities shall be clearly indicated on top right side of the catalogue. Accessories and optional equipment included in the prices shall be clearly indicated in red.
- K.E.C. shall submit a list of factory recommended spare parts for one (1) year satisfactory operation along with prices with the quotation.
- K.E.C. shall be required to submit two copies of catalogue cuts & installation drawings of all equipment in order to obtain owner's approval prior to shipment of goods.
- K.E.C. is required to fill up the time frame schedule as indicated below:



COMMERCIAL KITCHEN DESIGNERS

DESCRIPTION	TIME IN WEEKS
<ol style="list-style-type: none">1. APPROVAL OF CATALOGUES & BY CLIENT2. MANUFACTURE AND DELIVERY TO PART OF SHIPMENT3. TRANSPORTATION4. CUSTOM CLEARANCE5. INSTALLATION OF EQUIPMENT INCLUDING HOOK-UP6. TESTING & COMMISSIONING7. HANDING OVER	
<ul style="list-style-type: none">• Successful K.E.C. will be required to submit fabrication drawings with detail to scale not less than 1:25 for any custom built equipment ordered for owner's review and approval prior to manufacture. Drawings should show details of construction and materials to be used and indicate the requirements of plinths depressions, drains etc. required to be provided by others.• K.E.C. will be required to submit samples of materials and components in order to satisfy the owner in advance of the standards and quality of work man ship, i.e. handles, section of panels, interlocking arrangements of panels, hinges and other such hardware shall be submitted for approval along with the drawings.• K.E.C. is required to verify all dimensions from site of all equipment ordered with him and of other equipment that may have impact on his equipment being procured from elsewhere.• All items shall suit space conditions all dimensions given are approximately only and in all cases, where equipment is intended to occupy fixed locations and spaces, the physical condition of the building are to control and absolute sizes.• K.E.C. shall furnish all necessary information and measurement of the job site. This information shall be secure by others at the site of installation.• K.E.C. shall be required to liaise with project manager regarding accessibility of his equipment and to the site of location and make necessary arrangement for their access.• The K.E.C. shall provide all necessary holes and / or opening in the equivalent, which may be required for the proper installation of the plumbing, electrical, ventilating and refrigeration connections.• K.E.C. shall submit a program of manufacturing, delivery and installation and the likely date for inspection within (2) weeks of placing orders.• K.E.C. will be required to show the equipment to the owner's representative during fabrication i.e. prior to assembly and before dispatch.	



COMMERCIAL KITCHEN DESIGNERS

Design Parameter for Chiller





- Supplier shall submit a separate data sheet showing the B.T.U's table, as per their calculations for each of the Cold Room, for review by clients/ consultants. Following considerations to be taken
Temperature of incoming products as fresh @ 24 Deg. C to 30 Deg C to be considered
- The perishables product load to be stored and withdrawn from the Cold Room shall be considered on the basis of storage baskets and pans kept on 5-tiered shelving racks positioned all along the wall (50 Kg/ Sq. m)
- The capacity of the refrigeration system should be re-verified by supplier as per their standards.
- The usage of doors (opening and closing) should be considered for a high volume of operation. Ambient of 43 Deg C (APPROX 5 to 7 times in one hrs).

Design Parameter for Freezer

- Supplier shall submit a separate data sheet showing the B.T.U's table, as per their calculations for each of the Cold Room, for review by clients/ consultants. Following considerations to be taken
Temperature of incoming products as fresh @ 5 Deg C to 8 Deg to be considered
- The perishables product load to be stored and withdrawn from the Cold Room shall be considered on the basis of storage baskets and pans kept on 5-tiered shelving racks positioned all along the wall (30 Kg/ Sq. m)
- The capacity of the refrigeration system should be re-verified by supplier as per their standards.
- The usage of doors (opening and closing) should be considered for a high volume of operation. Ambient of 43 Deg. C (APPROX 3 to 5 times in one hrs).



COMMERCIAL KITCHEN DESIGNERS

Drawing Reference No						
Item						
WALK-IN COLDROOMS +2 to +5 Deg C		Representational Image				
Quantity		 				
1	Unit Nos.					
Size in mm						
Width (L)	Depth (B)			Height (H)		
AS PER SPECS ATTACHED						
Capacity						
As per Selection						
Make & Model				Suggested	Alternate 1	Alternate 2
Make				TRUFROST	BLUESTAR	RINAC
Model						
MEP Requirements		Specification				
Plumbing		<p>PUF Panels 60mm thick for Chiller. Wall to Wall, Wall to Floor, Wall to Ceiling with <i>Built-in round-off wall corners</i>. "T" joint cam-lock interlocking with rounded corners for joining two coldrooms together. No use of flashing/riveting to join two rooms.</p> <p>Factory installed PVC gaskets in all PUF Panels for 100% leak-proof jointing. No use of silicon sealant to fill joint gaps</p> <p>All Inside Wall & Ceiling Area are 0.5mm Stainless Steel SS304</p> <p>Outside Exposed Wall Area 0.8mm Stainless Steel SS304</p> <p>Outside Un-exposed Wall Area 0.5mm Preapainted GI Sheet</p> <p>Galvanized steel cladded (0.5mm top /0.5mm)PUF Panels.</p> <p>Cam locks -Wall to Wall, Wall to Ceiling, Wall to Floor. Corner 'L' panels with round-off corner panel, with Cam-lock jointing with side panels</p> <p>Door will Right/ Left hand side Hinged and Flushed. Built-in cylindrical lock, with cam lift-type self-closing door</p> <p>Dimensions: 850 x 1980mm High (opening)</p> <p>BITZER Germany factory-make Semi-hermetic Aircooled Condensing Unit</p> <p>Evaporators with SS Casing. Centrally Ceiling -mounted Slim-line evaporator with 150mm height. Dual-side Air Discharge design for uniform air flow .</p> <p>Microprocessor based programmable Control Panel for Freezer & Chiller rooms with Isolators, Single Phase protection</p> <p>Hi-Lo Voltage Protection, Defrost Control, Temperature Control, Compressor Running indicator functions.</p> <p>Condensate water from evaporator unit to be routed through wall mounted wall drain traps. SS Box including P-trap to flush fit in civil wall cavity. Site coordination to be done for fitment of SS box as per site condition</p>				
Cold	Ø		Inch			
Hot	Ø		Inch			
RO	Ø		Inch			
Waste	Ø		Inch			
Condensate	Ø	1	Inch			
Pressure			Bar			
Electrical		<p>Phase</p> <p>Supply</p> <p>Hz</p> <p>Load (KW)</p>				
3	415	50	As per selection			
Gas		<p>Connection</p> <p>Pressure</p> <p>BTU</p>				
	Ø		Inch			
			Bar			
HVAC		<p>Exhaust</p> <p>Fresh Air</p> <p>CFM</p> <p>CFM</p>				
Accessories		<p>Trap Alarm, High-Low Temperature Alarm, PVC Strip Curtain, View Port in Chillers, 1mm SS Kick Plate on both side of Door, Vapour Proof IP 65 casing for light</p>				
Special Notes:		<p>Condensing units & Evaporators for Chiller rooms</p>   				



COMMERCIAL KITCHEN DESIGNERS

Drawing Reference No									
Item									
WALK-IN FREEZER ROOM -18 to -20 Deg C				Representational Image					
Quantity									
1		Unit Nos.							
Size in mm									
Width (L)		Depth (B)						Height (H)	
AS PER SPECS ATTACHED									
Capacity									
As per Selection									
Make & Model				Suggested		Alternate 1		Alternate 2	
Make				TRUFROST		BLUESTAR		RINAC	
Model									
MEP Requirements				Specification					
Plumbing				<p>PUF Panels 100mm thick for Freezer. Wall to Wall, Wall to Floor, Wall to Ceiling with <i>Built-in round-off wall corners</i>. "T" joint cam-lock interlocking with rounded corners for joining two coldrooms together. No use of flashing/riveting to join two rooms.</p> <p>Factory installed PVC gaskets in all PUF Panels for 100% leak-proof jointing. No use of silicon sealant to fill joint gaps</p> <p>All Inside Wall & Ceiling Area are 0.5mm Stainless Steel SS304</p> <p>Outside Exposed Wall Area 0.8mm Stainless Steel SS304</p> <p>Outside Un-exposed Wall Area 0.5mm Prepainted GI Sheet</p> <p>Galvanized steel clad (0.5mm top /0.5mm) PUF Panels.</p> <p>Cam locks -Wall to Wall, Wall to Ceiling, Wall to Floor. Corner 'L' panels with round-off corner panel, with Cam-lock jointing with side panels</p> <p>Door will Right/ Left hand side Hinged and Flushed. Built-in cylindrical lock, with cam lift-type self-closing door</p> <p>Dimensions: 850 x 1980mm High (opening). Door with Heater on Door Frame</p> <p>BITZER Germany factory-make Semi-hermetic Aircooled Condensing Unit</p> <p>Evaporators with SS Casing. Side Ceiling -mounted Slim-profile evaporator with high CFM fans. Electric Heater for Defrosting. Heater on Coil, Tray & Drain Line</p> <p>Microprocessor based programmable Control Panel for Freezer & Chiller rooms with Isolators, Single Phase protection</p> <p>Hi-Lo Voltage Protection, Defrost Control, Temperature Control, Defrost Indicator, Compressor Running indicator function</p> <p>Condensate water from evaporator unit to be routed through wall mounted wall drain traps. SS Box including P-trap to flush fit in civil wall cavity. Site coordination to be done for fitment of SS box as per site condition</p>					
Cold	∅		Inch						
Hot	∅		Inch						
RO	∅		Inch						
Waste	∅		Inch						
Condensate	∅	1	Inch						
Pressure			Bar						
Electrical									
Phase	Supply	Hz	Load (KW)						
3	415	50							
Gas									
Connection	∅		Inch						
Pressure			Bar						
BTU									
HVAC									
Exhaust			CFM						
Fresh Air			CFM						
Accessories	Trap Alarm, High-Low Temperature Alarm, PVC Strip Curtain, Pressure Relief Vent, 1mm SS Kick Plate on both side of Door, Vapour Proof IP 65 casing for light								
Special Notes: Condensing units & Evaporators for Freezer rooms									



COMMERCIAL KITCHEN DESIGNERS

COLD ROOM WALL DRAIN SYSTEM

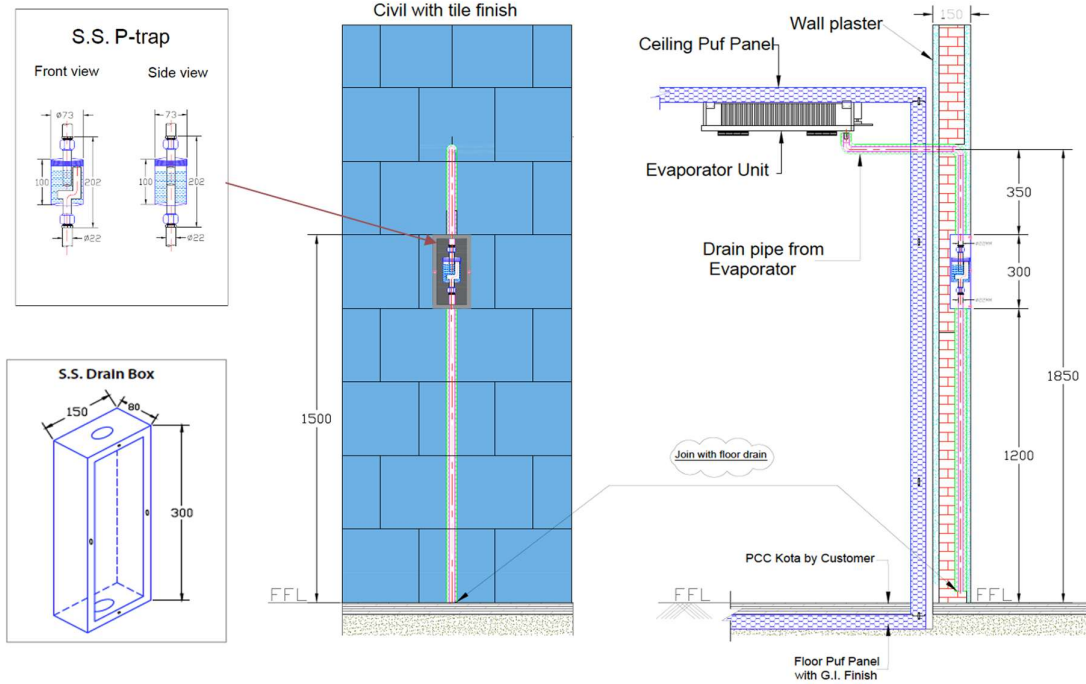

Wall Drain System



COMMERCIAL KITCHEN DESIGNERS

TYPICAL FLOORING DETAILS FOR COLD ROOM

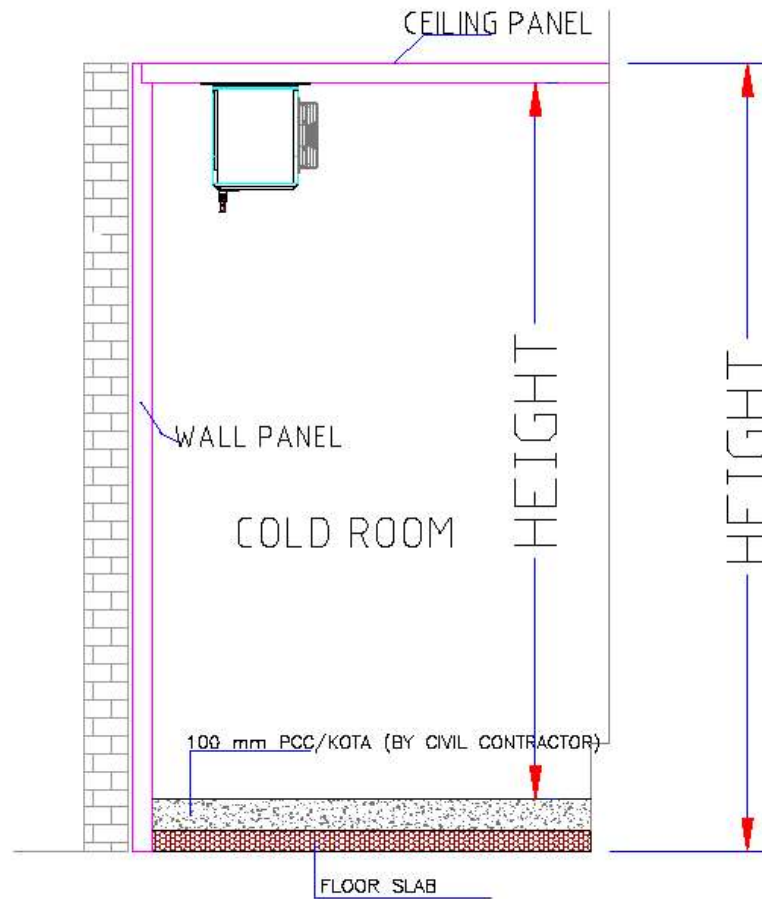



COMMERCIAL KITCHEN DESIGNERS

EXHAUST HOOD DETAILS

- ❖ Entire Hoods Fabricated from 18g SS Sheet with SS Openable (Washable) Grease Stop Filters.
- ❖ Hoods to be supplied with LED Lights with Shatter proof Glass.
- ❖ Hoods to be supplied with Grease Tray or Drain Plug.
- ❖ Hood must be erected on site and hung from the slab/Wall with necessary bolts, Rods and fasteners.

Sizes as per BOQ. (Contractor to cross check the same at site before Manufacturing)



FILTER: OPENABLE (WASHABLE) GREASE STOP BAFFLE TYPE FILTER.

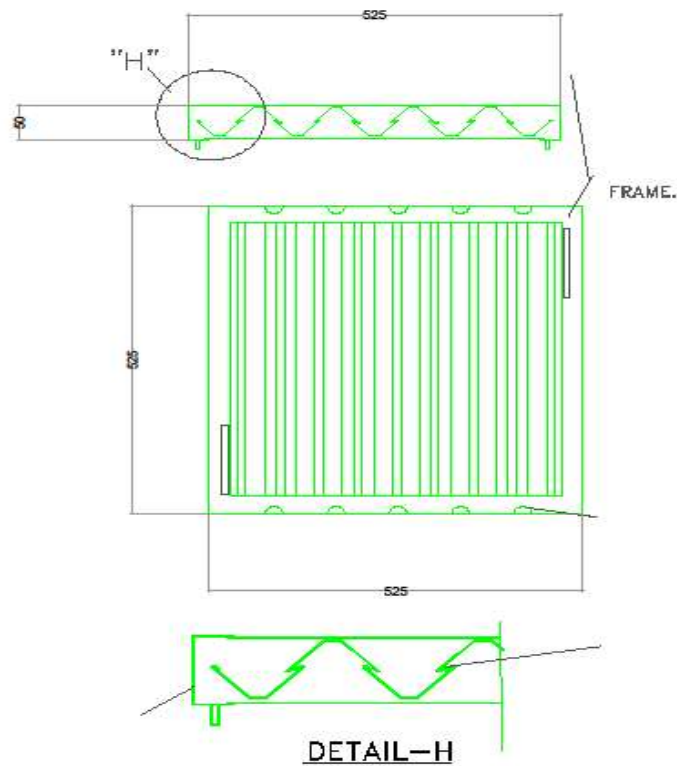

PROVIDE 1MM DISTANCE BETWEEN TWO STRIPS.



COMMERCIAL KITCHEN DESIGNERS

TYPICAL DRAIN GRATING

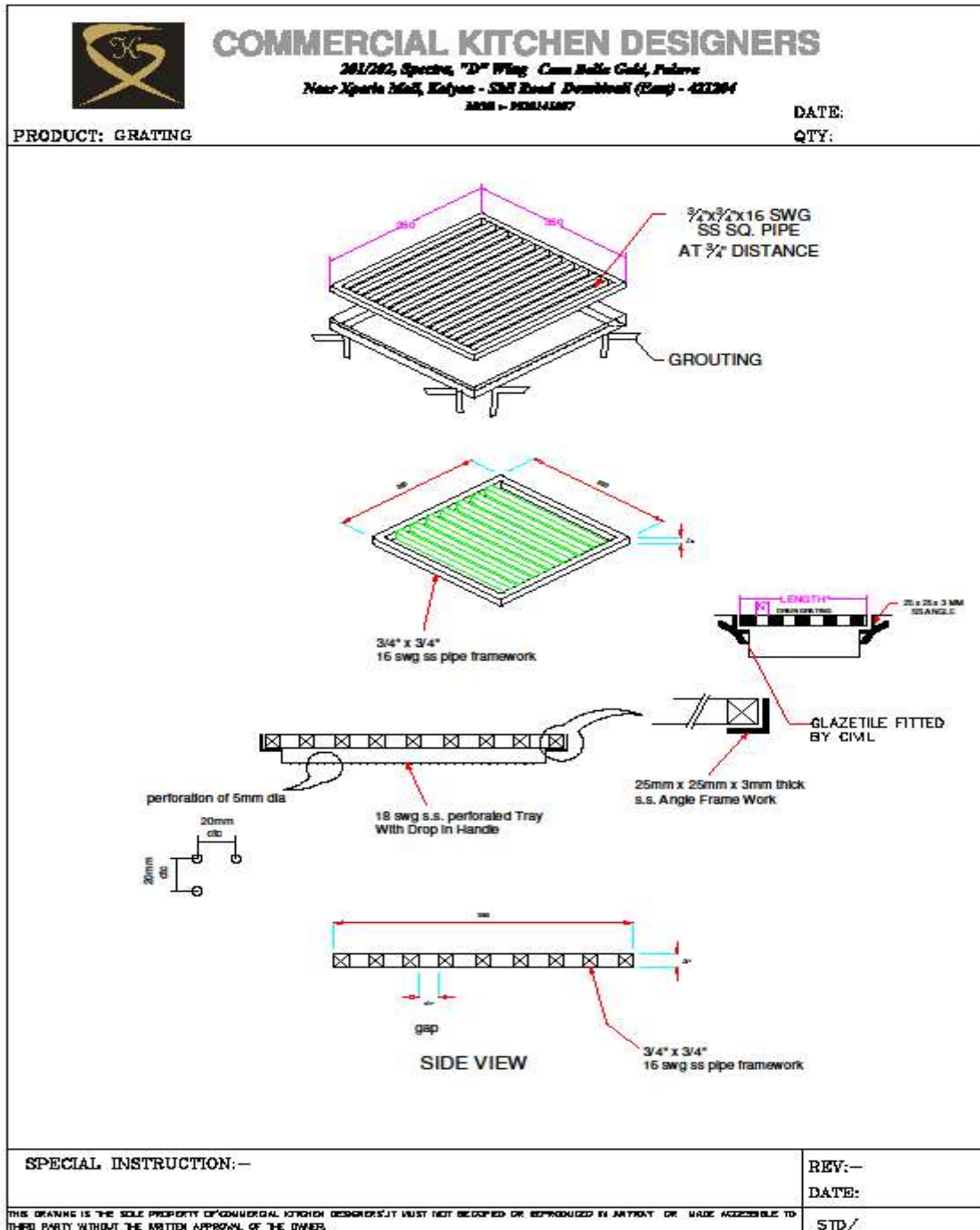



COMMERCIAL KITCHEN DESIGNERS



COMMERCIAL KITCHEN DESIGNERS

FABRICATION DETAIL SHEET

WORK TOP DETAILS

PLAIN TOP

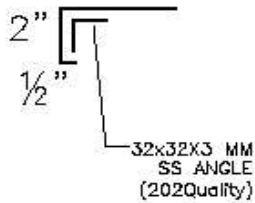

PLAIN TOP WITH SPLASH DETAILS

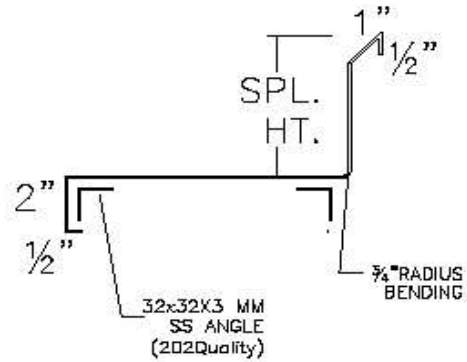

SUNK IN TOP

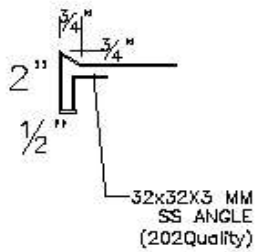

SUNK-IN TOP WITH SPLASH DETAILS

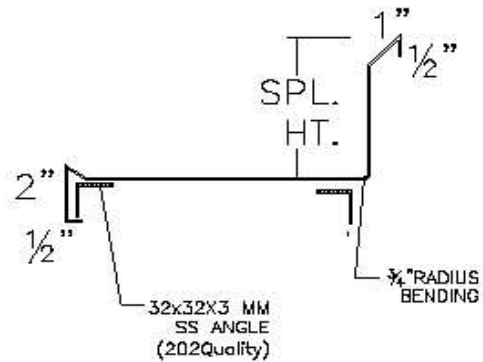



COMMERCIAL KITCHEN DESIGNERS

PRE _ RINSE TABLE BENDING DETAILS

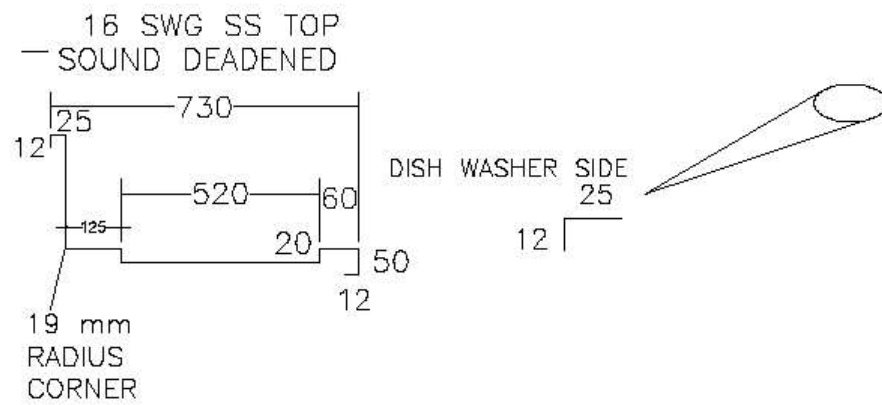



COMMERCIAL KITCHEN DESIGNERS

SPECIAL NOTE: -

- **Individual Equipment Drawings, which are part of CKD tender docket are for representable purpose only. To assist K.E.C in quotation. Its Responsibility of K.E.C to submit Shop drawings with plan, elevation and section for approval.**
- **The kitchen Contractor shall re-verify the actual site dimensions and conditions in compliance with requirements with specific conditions. The re checking of such drawings vis a vis the site shall not relieve the Kitchen Equipment Contractor from the responsibility of any deviations from the drawings and specifications unless such deviations are approved in writing by CKD.**
- **LEGS/UPRIGHTS (To Follow Uniform Pipe Construction)**
All legs/uprights will be constructed of 1 ½” Dia. Stainless Steel tubes / 32x 32 MM Square Pipe of 16 SWG 304 Quality, spaced not more than six feet on centre. All legs will be fitted with Ferro 1000 nylon adjustable 1 ½” bullet feet. Units more than 1800 mm in length will have 3 pairs of uprights. Maintain Uniform Pipe Profile
- **SPALSH BACK TO BE UNIFROM PROFILE EITHER STRAIGHT OR ANGLE.**



COMMERCIAL KITCHEN DESIGNERS

REFRIGERATION DETAILS

SPECIAL INSTRUCTION:

- *1. UNIT TO HAVE ARRANGEMENT OF PAD LOCK.
- *2. REFRIGERATED CABINET TO HAVE 100% CFC- FREE R134a REFRIGERANT.
- *3. INNER TANK TO HAVE ROUNDED $\frac{3}{4}$ " RADIUS SIDE CORNERS & ROUNDED $\frac{3}{8}$ " RADIUS CORNER FOR BOTTOM TRAY.

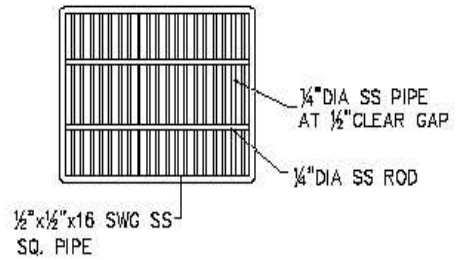
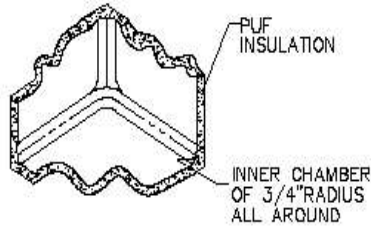
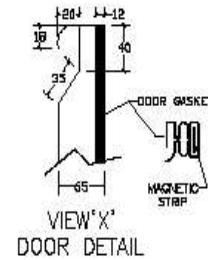

REMOVABLE WIRE ROD SHELVES
(EACH COMPARTMENT TO BE PROVIDED
WITH 2 NOS. SHELVES)

Three Door Work Top Refrigerator (Compressor on RHS) With Cold Bain Marie on top and With 3 OHS. With Infra-Red Heaters

Over All Size: - 1800 x 750 x 850 + 450 + 300 + 250

Qty: - 1 No.

Item Number: - MK-09



COMMERCIAL KITCHEN DESIGNERS

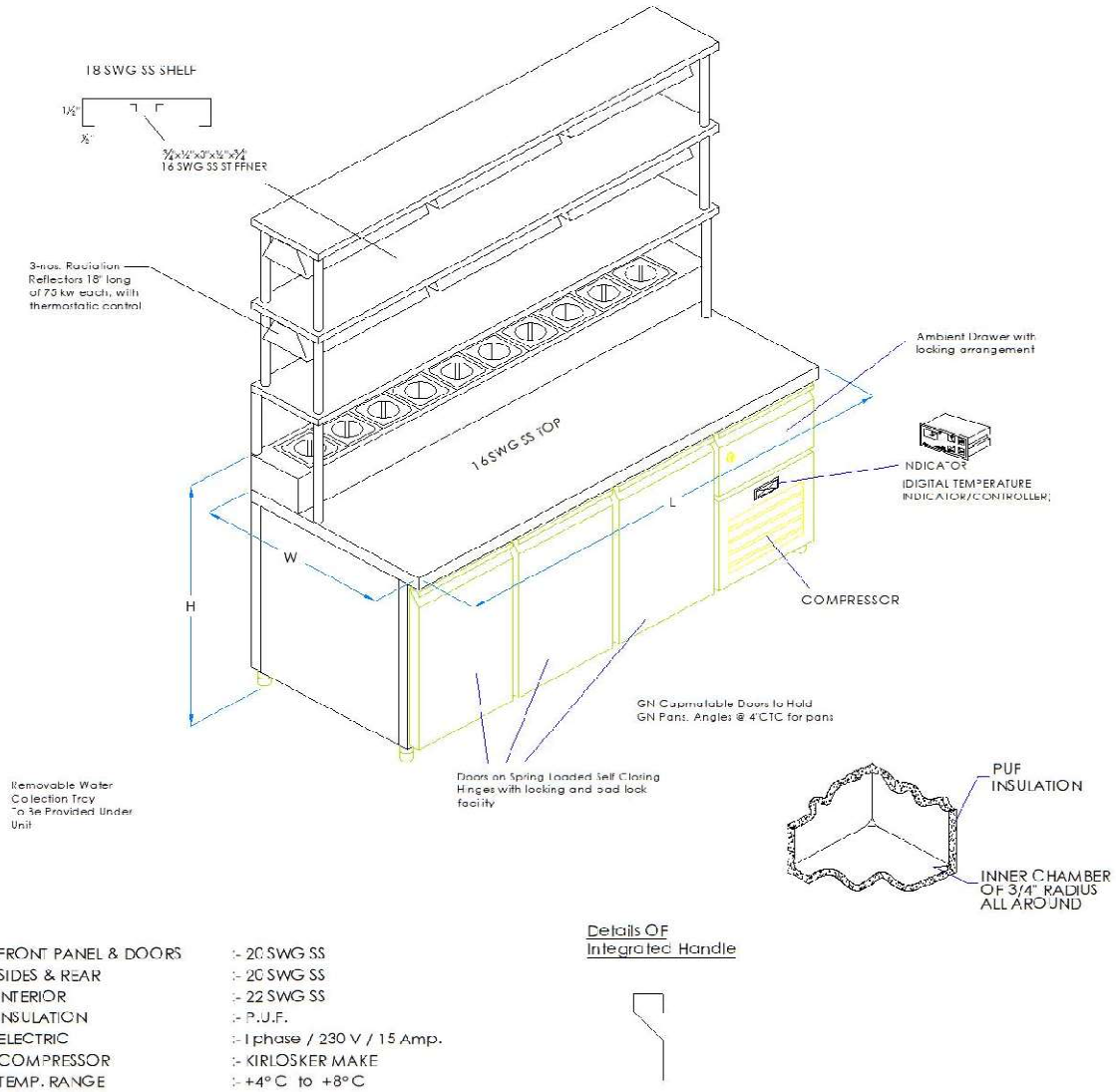

Two Door Work Top Chiller With Cold Bain Marie on Top (Compressor on LHS)

Over All Size:- 1500 x 600 x 850 + 150

Qty:- 1 Number

Item Number:- PP-02



COMMERCIAL KITCHEN DESIGNERS

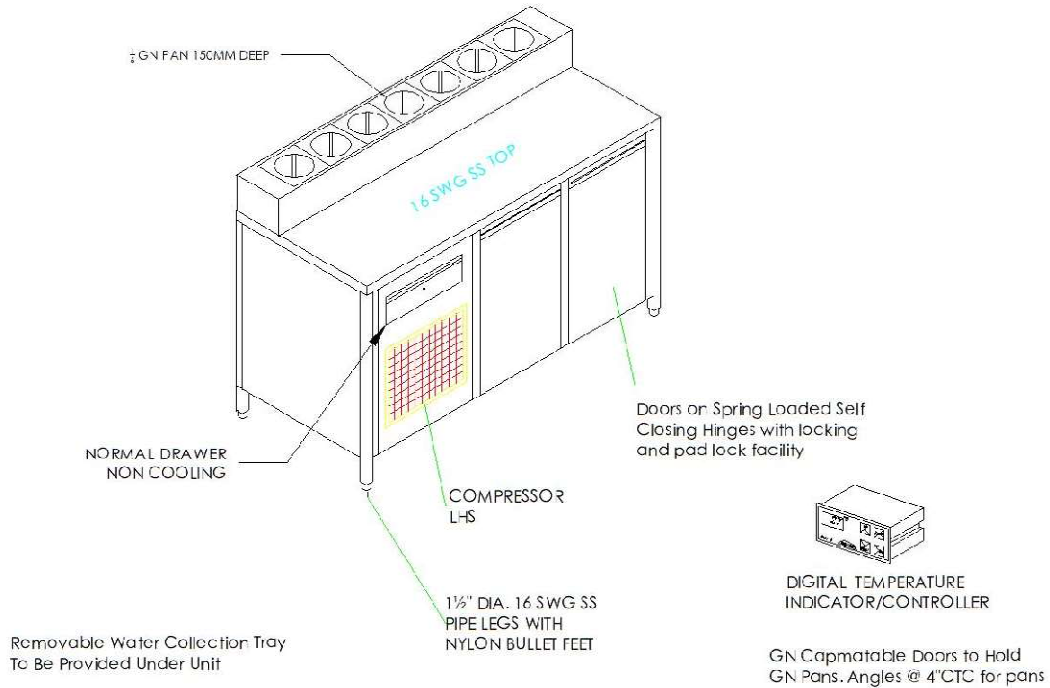

- FRONT PANFI & DOORS :- 20 SWG SS
- SIDES & REAR :- 20 SWG SS
- INTERIOR :- 22 SWG SS
- INSULATION :- P.U.F.
- ELECTRIC :- 1 phase / 230 V / 15 Amp.
- COMPRESSOR :- KIRLOSKER MAKE
- TEMP. RANGE :- +4° C to +8° C

Details OF Integrated Handle

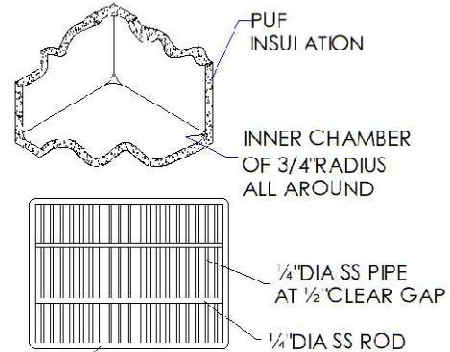
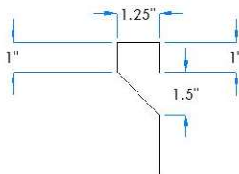

1/2 x 1/2 x 16 SWG SS SQ. PIPE

REMOVABLE WIRE ROD SHELVES (EACH COMPARTMENT TO BE PROVIDED WITH 1 NO. SHELVE)

PLATE COUNTER

Over All Size:- 1650 x 300 x 850

Qty:- 1 Number

Item Number:- MK-08



COMMERCIAL KITCHEN DESIGNERS

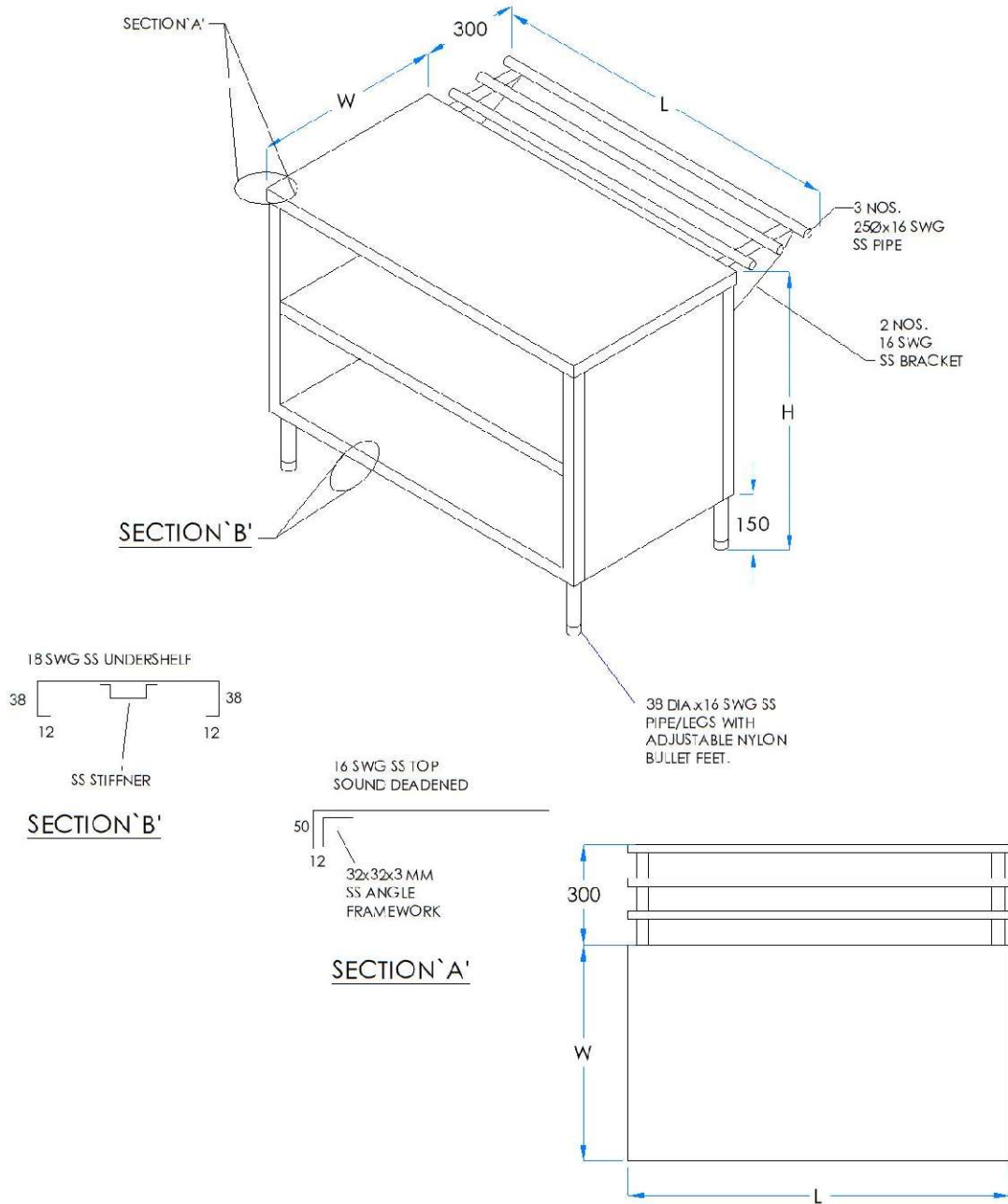

SIDE TABLE WITH 2 U/S

Item Number: - MK-11

Item Number: - MK-14

Item Number: - MK-16

Over All Size: - 250 x 730 x 850 + 150 QTY: - 1 No.

Over All Size: - 300 x 730 x 850 + 150 QTY: - 1 No.

Over All Size: - 325 x 730 x 850 + 150 QTY: - 1 No.



COMMERCIAL KITCHEN DESIGNERS

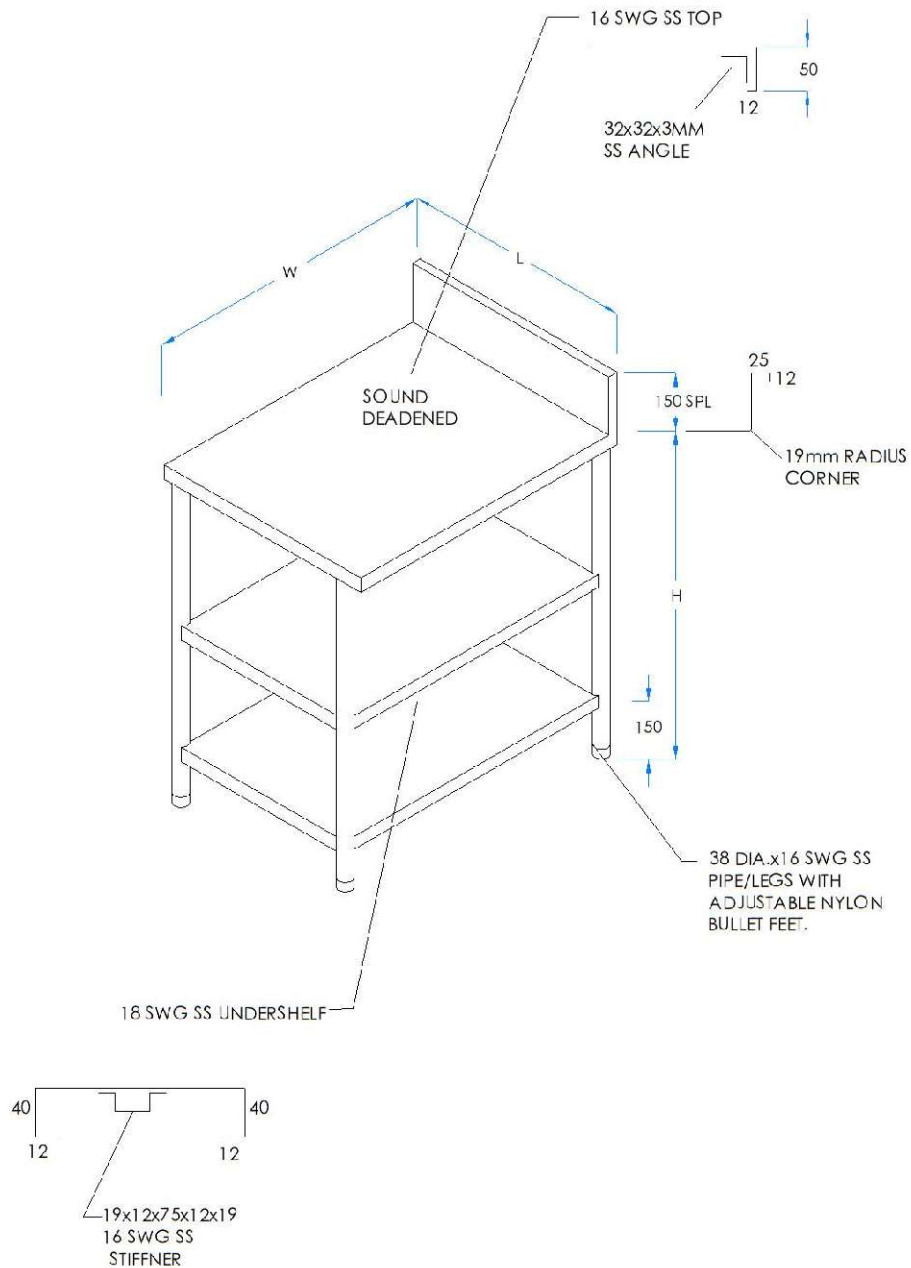

Twin Basket Electrical Deep Fat Fryer - 8 Litres Capacity Each Container

Over All Size:- 625 x 730 x 850 + 150

Qty:- 1 Number

Item Number:- MK-15



COMMERCIAL KITCHEN DESIGNERS

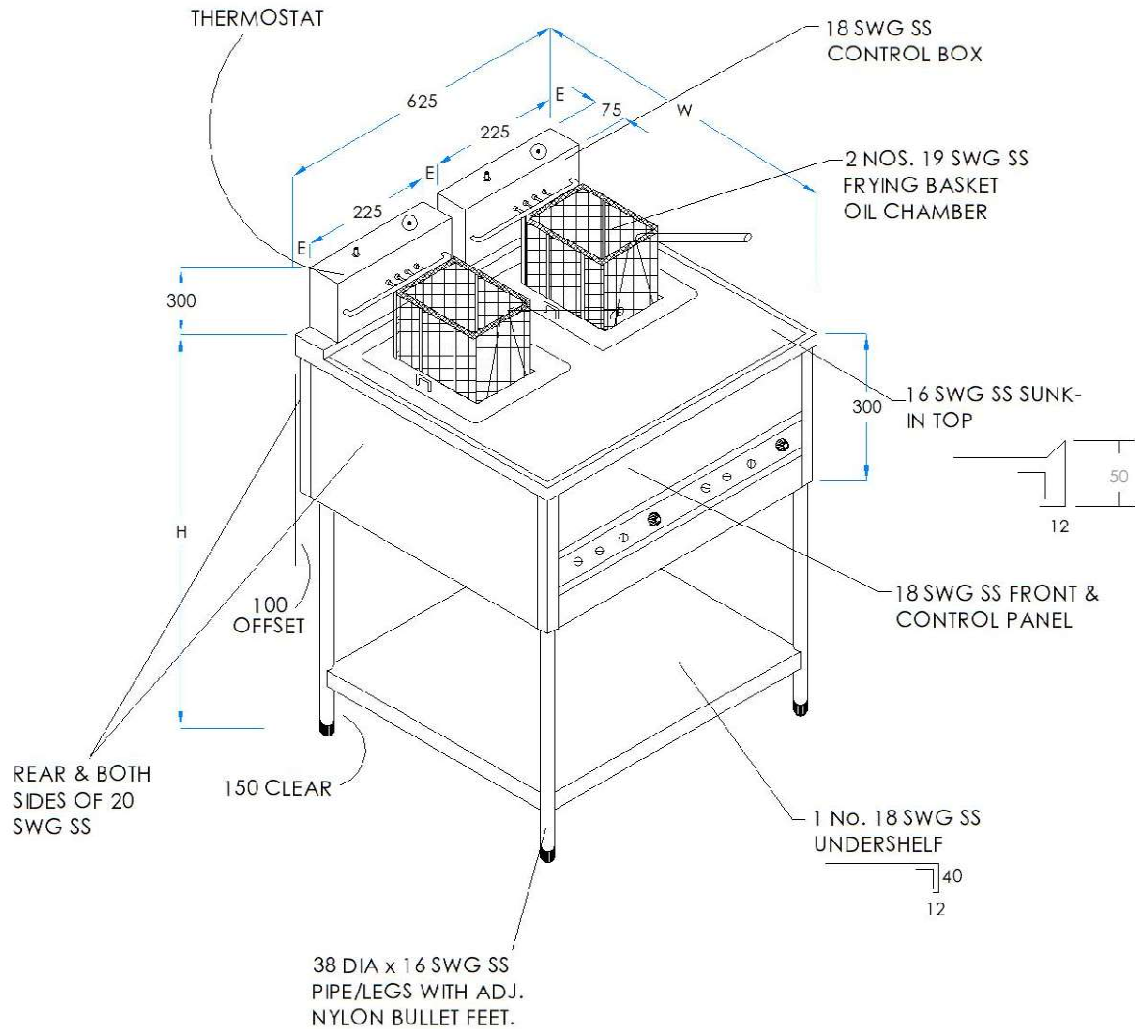

Storage Rack - 5 Shelves (3 Sides Up and 1 Side Down)

Over All Size:- 730 x 450 x 1800

Qty:- 1 Number

Item Number:- MK-17



COMMERCIAL KITCHEN DESIGNERS

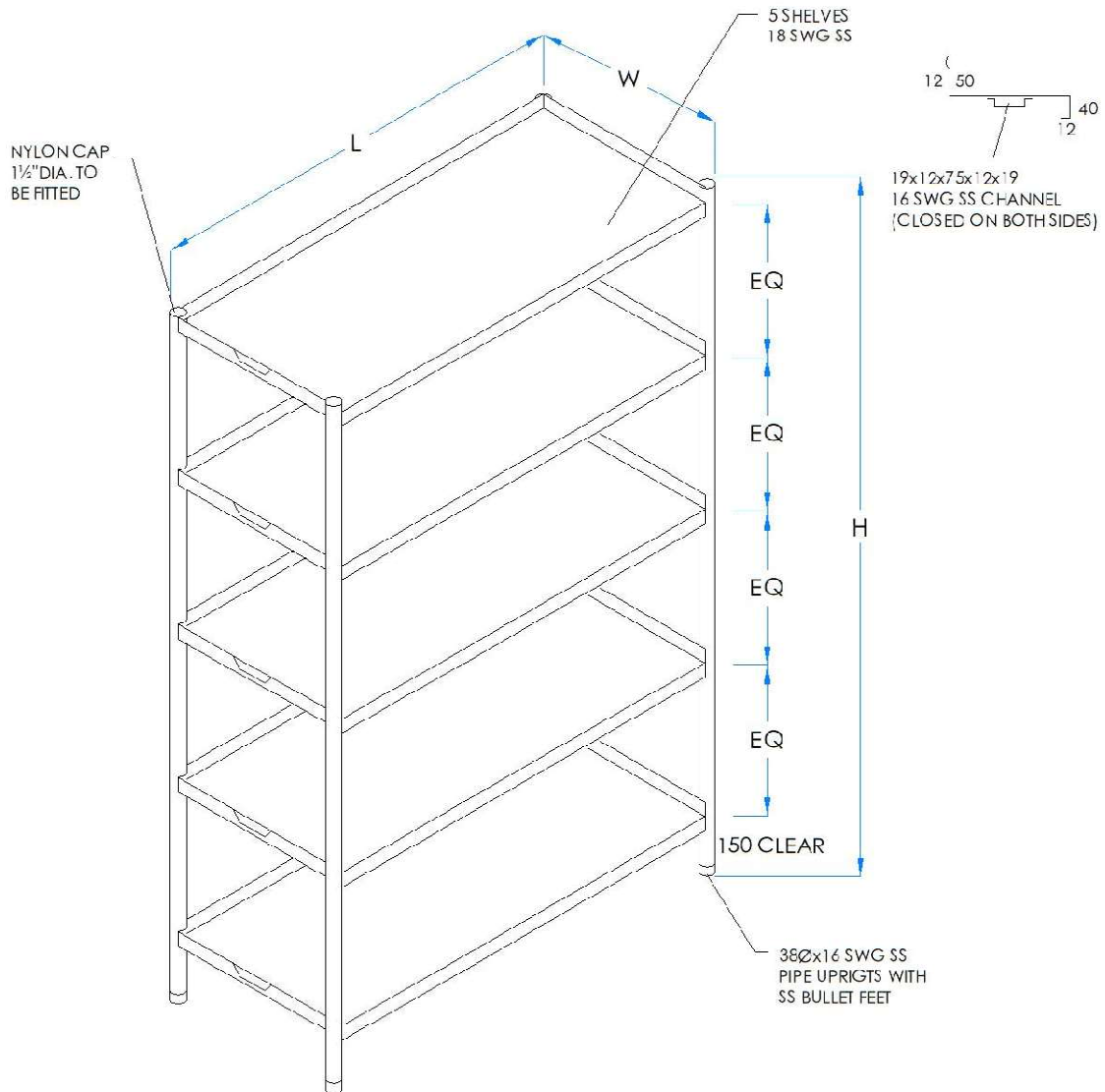

Wall Shelves

Item Number: - PP-04

Over All Size: - 1500 X 300

QTY: - 2 No.

Item Number: - PP-14

Over All Size: - 1250 X 300

QTY: - 2 No.



COMMERCIAL KITCHEN DESIGNERS

Item Number:- PP-05

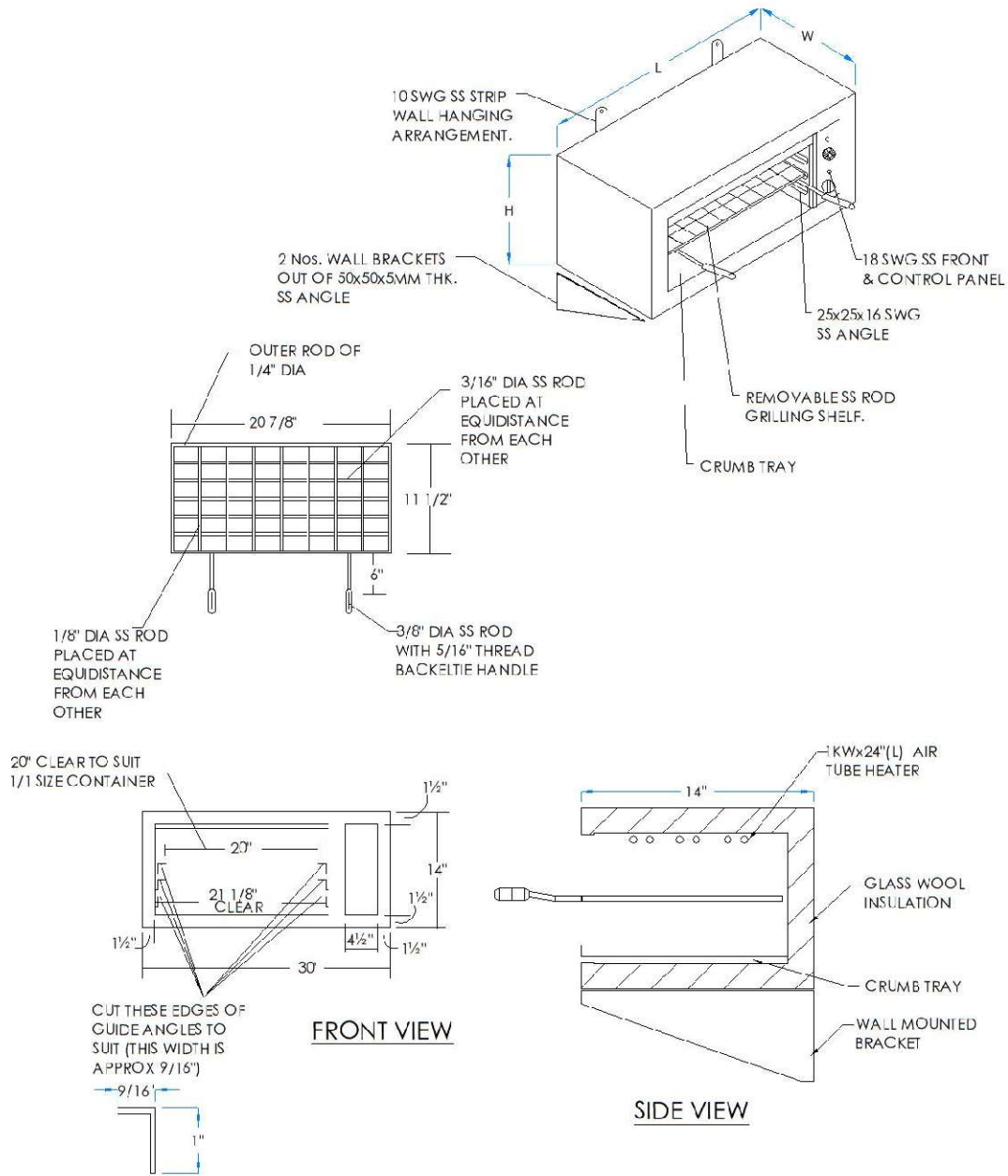

Work Table With 2 U/S

Over All Size:- 850 x 600 x 850 + 150



COMMERCIAL KITCHEN DESIGNERS

Qty:- 1 Number

Item Number:- PP-06

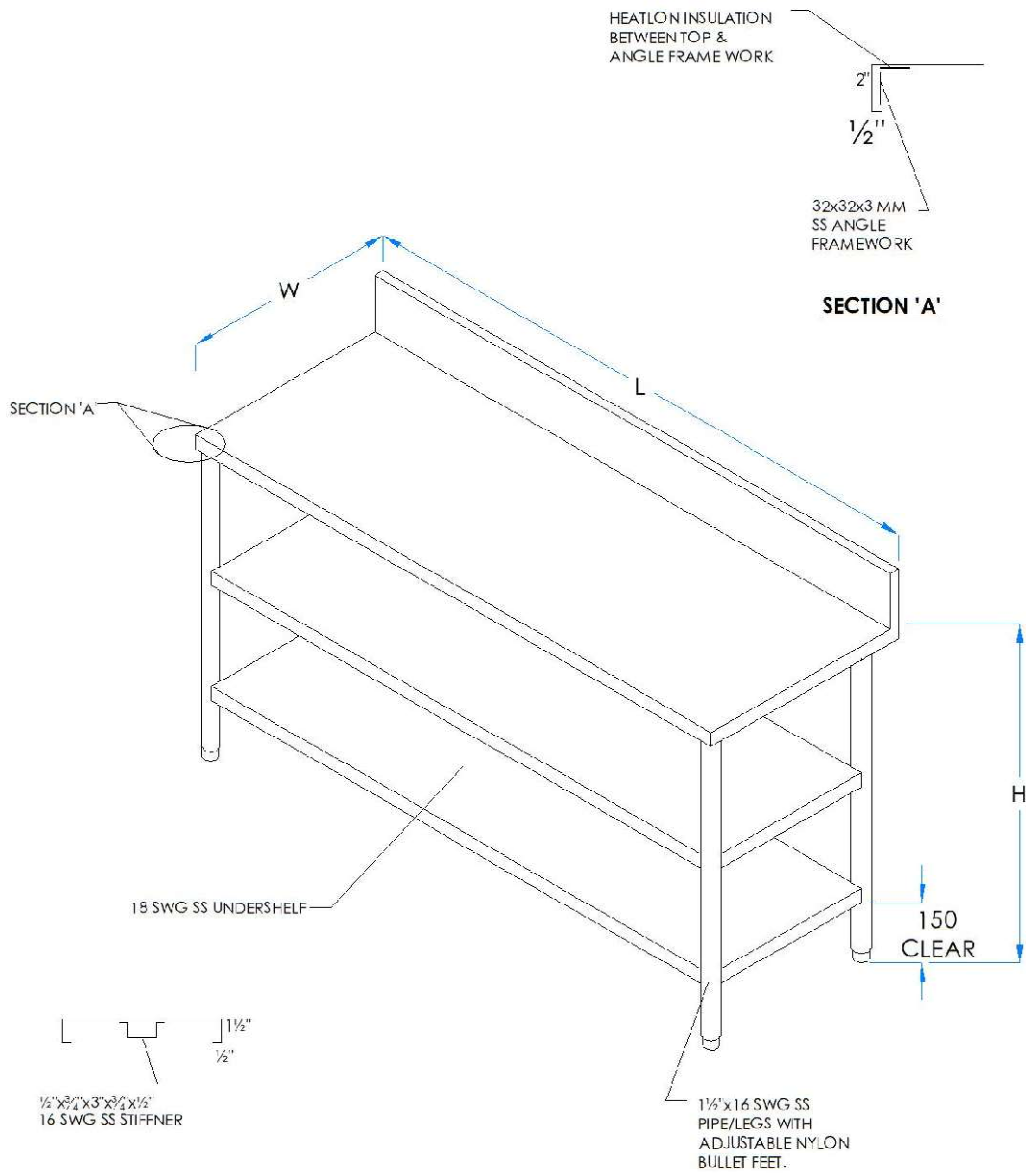

Work Table With Cross Bracing

Over All Size:- 1250 x 600 x 850 + 150

Qty:- 1 Number



COMMERCIAL KITCHEN DESIGNERS

Item Number:- PP-10

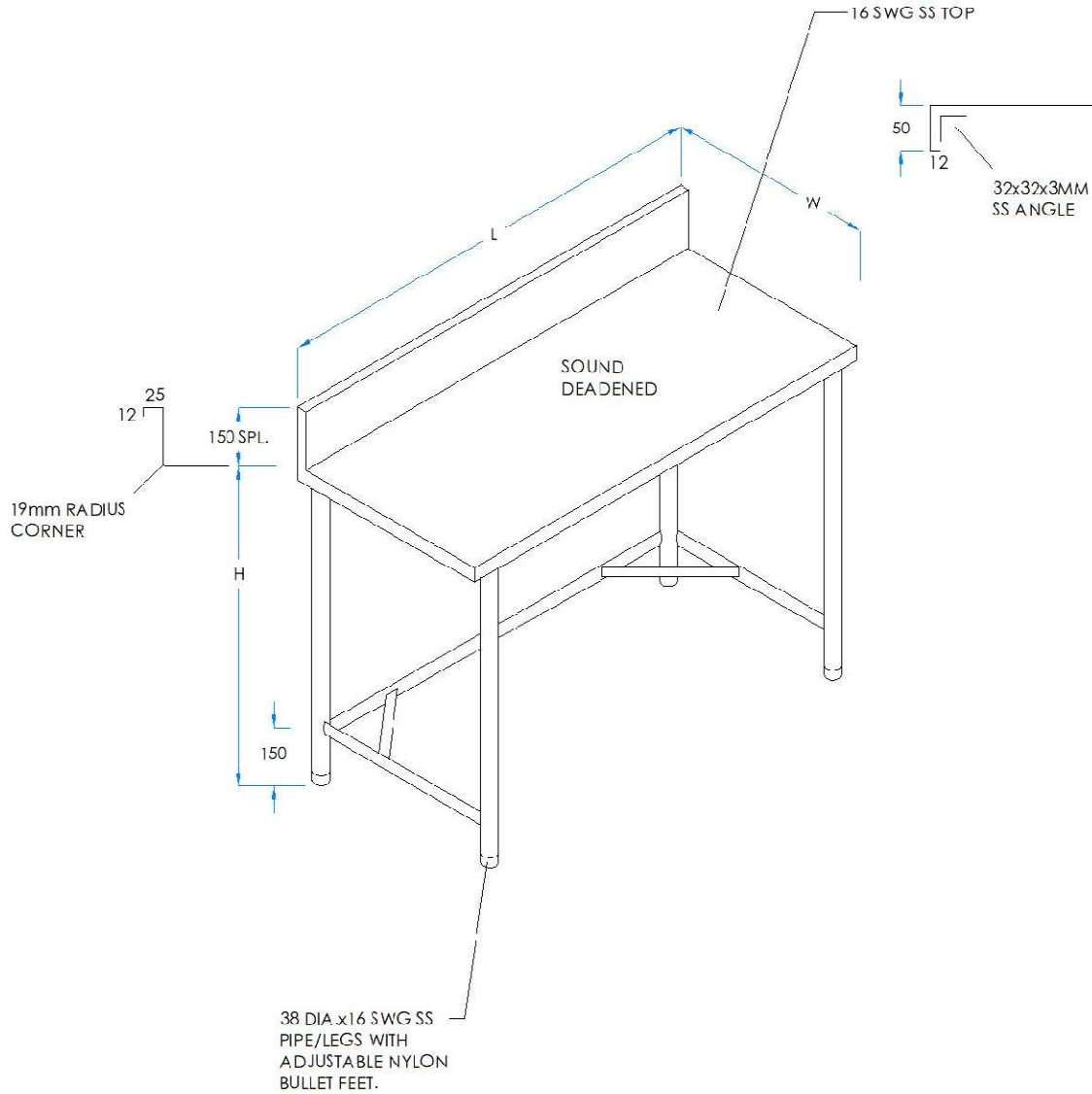

Atta - Maida Bin on Wheels

Over All Size:- 450 x 450 x 700



COMMERCIAL KITCHEN DESIGNERS

Qty:- 1 Number each

Item Number:- PP-11 & PP-12

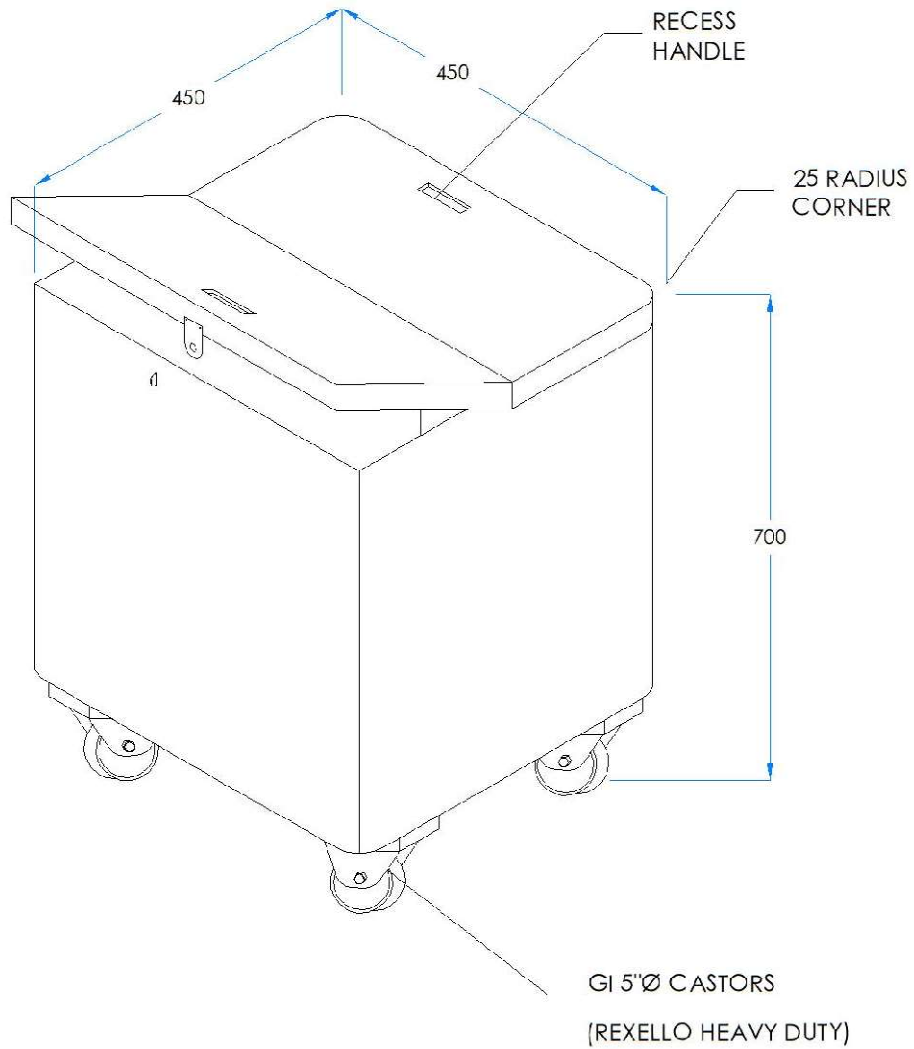

CONSTRUCTION : TANK & LID OF
18 SWG SS

Dish Landing Table with Garbage Chute

Over All Size:- 1200 x 740 x 850 + 150



COMMERCIAL KITCHEN DESIGNERS

Qty:- 1 Number

Item Number:- DW-01

16 SWG SS
SUNK-IN TOP
SOUND DEADENED
100 100 50

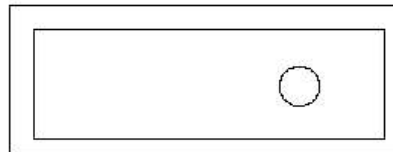
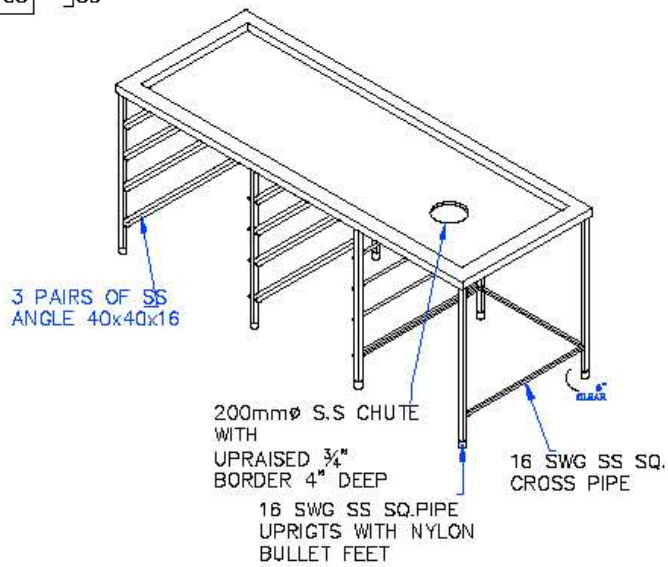

Pre Rinse Two Sink Unit



COMMERCIAL KITCHEN DESIGNERS

Qty:- 1 Number

Item Number:- DW-04

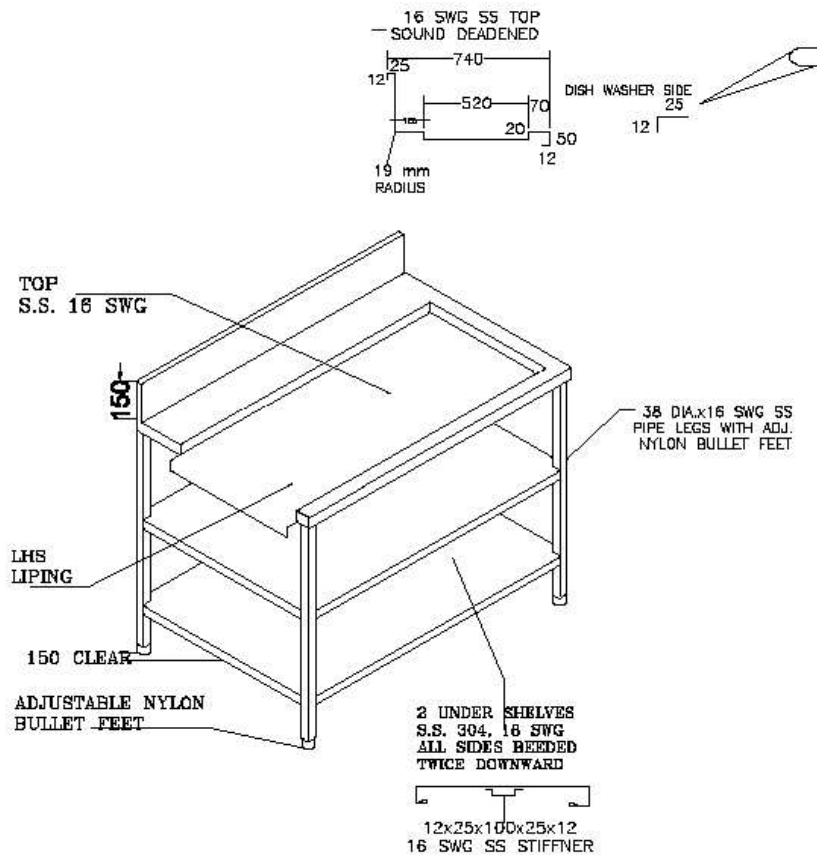

SPECIAL INSTRUCTION: - CHECK THE ORIENTATION AS PER PLACEMENT OF DISH WASHING MACHINE

Clean Dish Storage Rack - 5 Shelves (3 Sides Up and 1 Side Down)



COMMERCIAL KITCHEN DESIGNERS

Over All Size:- 900 x 450 x 1800

Qty:- 1 Number

Item Number:- DW-06

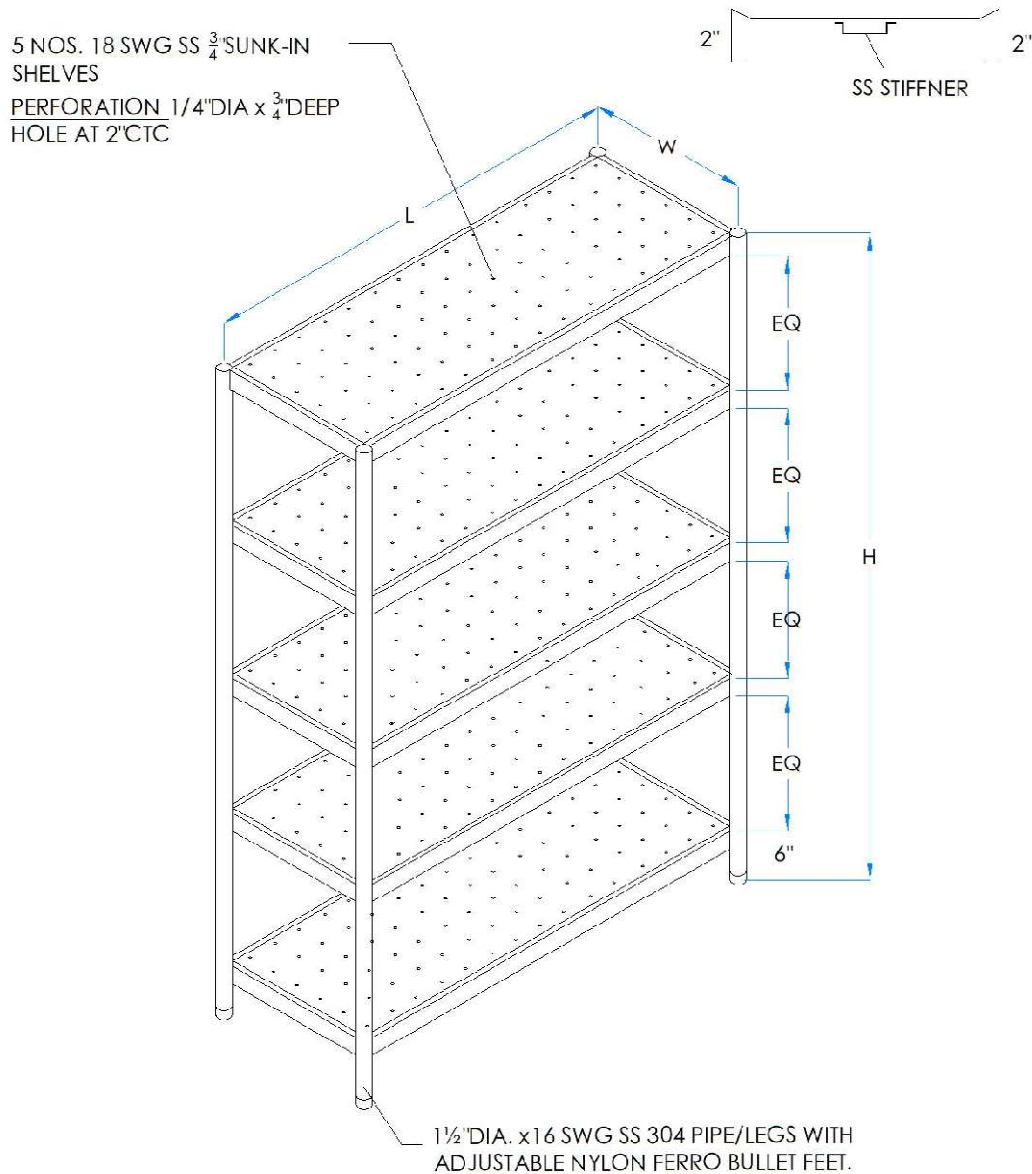

MS Slotted Angle Storage Rack (5 Shelves)

Over All Size:- 900X450X1800



COMMERCIAL KITCHEN DESIGNERS

Qty:- 1 Number each

Item Number:- BS-01, BS-02, BS-03 & BS-04

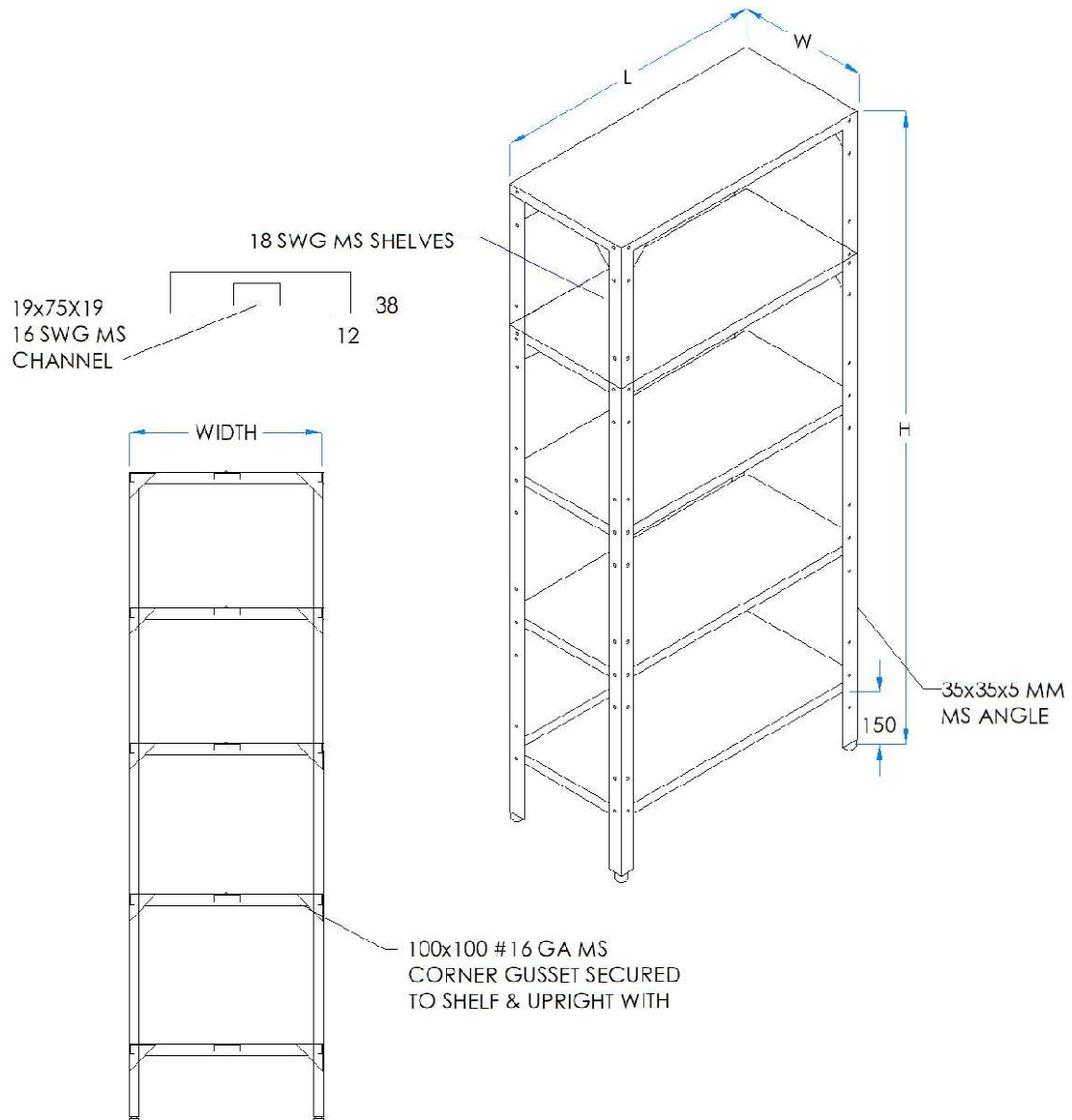



COMMERCIAL KITCHEN DESIGNERS

EXHAUST HOOD

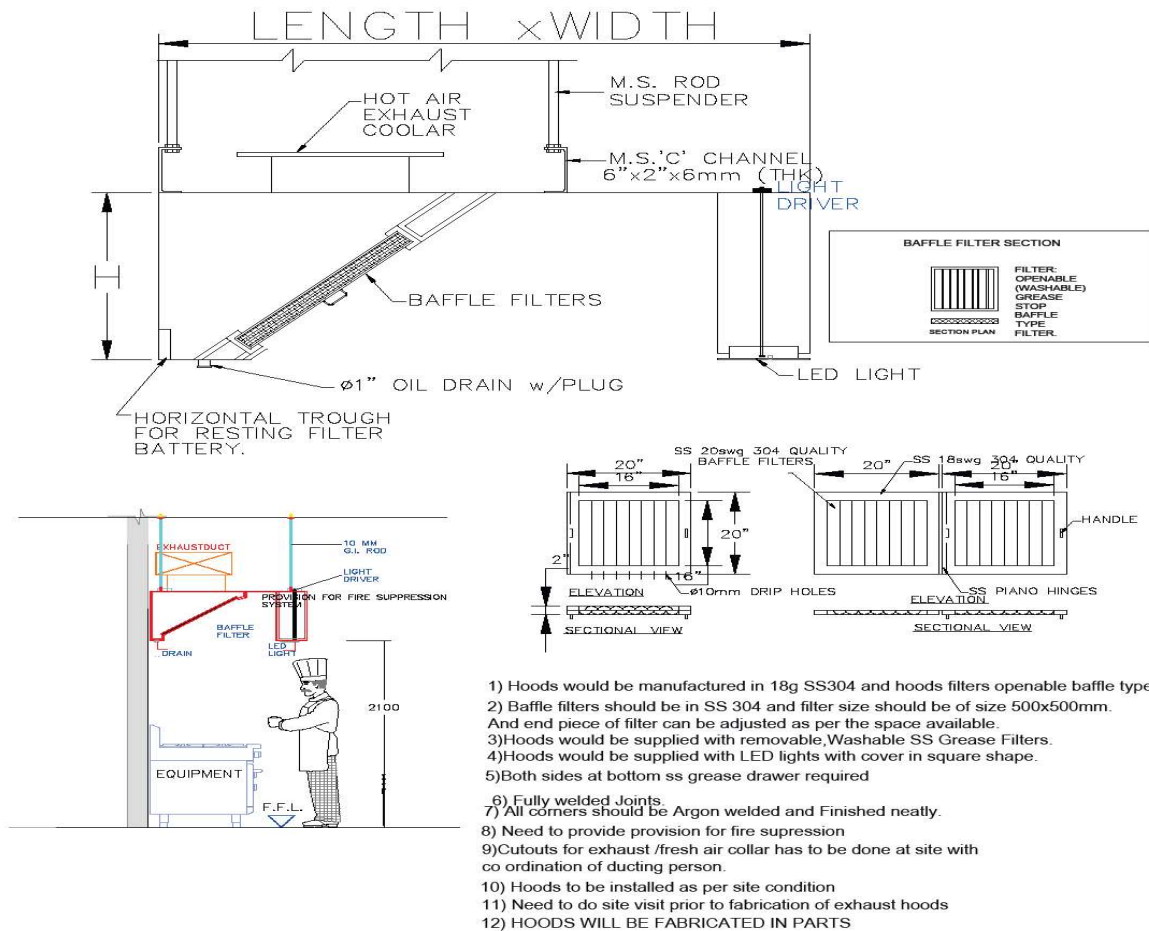

EX - 01	Exhaust Hood With SS Filters	2000 x 1000 x 500	1	CUSTOM FABRICATED
EX - 02	Exhaust Hood With SS Filters	900 x 900 x 500	1	CUSTOM FABRICATED

Electrical and Gas Accessories Approved Makes



COMMERCIAL KITCHEN DESIGNERS

1	Water Immersion Heaters	:	Escort / Spot – Heat / Vileco (Girish Electricals)
2	Stainless Steel Tubing On Heater (Liftable)	:	S.V. Enterprise / Spot – Heat / Vileco (Girish Electricals)
3	Air Heater Enclosed Tubing	:	S.V. Enterprise / Spot – Heat / Vileco (Girish Electricals)
4	Thermostat	:	EGO Make / Zumo
5	Rotary Switch	:	Thakur / Trinity Electricals / Kay Bee
6	Neon Indicating Lamps	:	S.V. Enterprise
7	Burners	:	Standard Make / United Make
8	Castors	:	Rexello Castors / Bombay Star
9	Compressors	:	Kirloskar Copeland / Shriram
10	Faucet	:	Jaquar / Cieko / ARK
11	Motor	:	Crompton / Siemens / New India / Hindustan / Kirloskar

ITEM NO: MK-28 & MK-35			MICROWAVE OVEN
ALL SIZES IN MM			IMAGE FOR REPRESENTATIVE PURPOSE ONLY
Width: 559	Depth: 483	Height: 352	
CAPACITY	35 LTRS		
M.E.P REQUIREMENT		SPECIFICATIONS	
PLUMBING :		<ul style="list-style-type: none"> • Counter Top. 	



COMMERCIAL KITCHEN DESIGNERS

Cold	ø	NA	
Hot	ø	NA	
Waste	ø	NA	
ELECTRIC :			
KW	1.6 KW		
Phase	230V 1 PH		
EXHAUST			
NA			
GAS:			
BTU	NA		
Con.	ø	NA	
ACCESSORIES:		Standard Accessories.	
SPECIAL NOTE:			
MAKE AND MODEL			
Menu master			
RCS 5111DSE			

- Inter & Exterior S.S Construction.
- Digital display.
- Countdown timer.
- With Two Magnetron(s).
- Programable.
- Removable airs filter with clean filter reminder.
- See through door,
- Pull handle door opening.

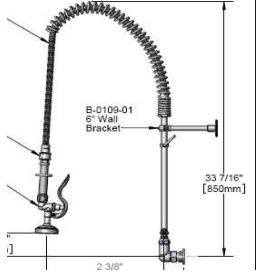
ITEM NO: DW-04 & DW-09			PRE- RINSE SPRAY UNIT WITH FAUCET		
SIZE ALL SIZES IN MM					
Width:	Depth:	Height:			
CAPACITY					
M.E.P REQUIRMENT			SPECIFICATIONS		
PLUMBING :			<ul style="list-style-type: none"> • Easy Install Pre-Rinse, Spring Action, 8" Wall Mount Base, Wall Bracket, & Swivel • 8" wall mount mixing faucet with polished chrome plated brass body, 		
Cold	ø	1/2"			
Hot	ø	1/2"			
Waste	ø	NA			



COMMERCIAL KITCHEN DESIGNERS

ELECTRIC :			
KW	NA		
Phase	NA		
EXHAUST			
NA			
GAS:			
BTU	NA		
Con.	ø	NA	
<ul style="list-style-type: none"> • 18" riser, • 44" flexible stainless-steel hose with heat resistant handle and swivel, • 1.42 GPM spray valve, compression cartridges with spring checks, • lever handles, • 1/2" NPT female inlets, • 6" adjustable wall bracket, • spray valve holder and overhead spring. • Certified to ASME A112.18.1/CSA B125.1, NSF 61- Section 9 and NSF 372. EP Act 2005 compliant 			
ACCESSORIES:		Wall mounting bracket and finger hook	
SPECIAL NOTE:			
MAKE AND MODEL			
BERJAYA MAKE			
T&S			

ITEM NO: DW-05			HOOD TYPE DISH WASH MACHINE		
SIZE ALL SIZES IN MM					
Width:	Depth:	Height:			
CAPACITY	35 LTRS				
M.E.P REQUIREMENT			SPECIFICATIONS		
PLUMBING :			Able to run at two speeds at the capacity of 48 racks per hour and 75 racks per hour as per DIN Standard.		
Cold	ø	12	Usable Chamber height 440mm		
Hot	ø	NA	Fully enclosed 4 sided hood design - avoiding loss of energy/steam (Energy saving system)		
Waste	ø	2"			
ELECTRIC :					



COMMERCIAL KITCHEN DESIGNERS

KW	9 KW	Water consumption: 2.5 lt/cycle Rinse	
PHASE	415V 3PH	pressure pump	
EXHAUST		Chemical Dispensers	
NA		CLIP-IN wash & rinse arms: wash & rinse arms can be removed with one hand and without any tool	
GAS:		Suits 500 x 500 Racks	
K.W.	NA	Patented WIDE ANGLE FAN nozzle to maximize wash and rinse performance	
Con.	NA	Self-cleaning cycle on drain out, USB Interface	
	NA	Optimum hygienic - deep drawn tank with covered corners (no welds)	
	NA	Ready to install: fill / drain hoses, electrical cable, detergent dispenser, rinse aid dispenser	
	NA	Able to wash 1/1 GN pan when using optional open ended tray racks	
ACCESSORIES:		AS PER THE BOQ ATTACHED	
SPECIAL NOTE:		Unit washing cycle Should be as per DIN Standard.	
MAKE AND MODEL			
DIHR		ELECTROLUX	
AD01001030B		AD0A00401	

ITEM NO : EXT-02			Water Boiler (Geyser)
SIZE ALL SIZES IN MM			IMAGE FOR REPRESENTATIVE PURPOSE ONLY
Width:	Depth:	Height:	
CAPACITY	35 Liters Capacity		
M.E.P REQUIRMENT		SPECIFICATIONS	



COMMERCIAL KITCHEN DESIGNERS

PLUMBING :				<ul style="list-style-type: none"> STANDARD
Cold	∅	12		
Hot	∅	NA		
Waste	∅	NA		
ELECTRIC :				
KW	3			
Phase	220v.50c.1p			
Gas:				
BTU	NA			
Con.	∅	NA		
ACCESSORIES:		Power cord, Complete with mounting arrangement.		
SPECIAL NOTE:				
MAKE AND MODEL				
RACOLD				
CDR 25 V/H				

ITEM NO: EXT-05			GARBAGE BIN
SIZE			IMAGE FOR REPRESENTATIVE PURPOSE ONLY
Width: 420 mm	Depth: 585 mm	Height: 790 mm	
CAPACITY	70 liters		
M.E.P REQUIRMENT		SPECIFICATIONS	



COMMERCIAL KITCHEN DESIGNERS

PLUMBING :				<ul style="list-style-type: none"> • Polyethylene Construction. • With rust, dent, chip or peel free. • Heavy duty Pedal Mechanism. • Tight fitting overlapping lid. • With Round Corner. • Container Equipped with two (02) nos rear side Wheels for better maneuverability. • Unit should be suitable for work in Food service area. • Color and qty as per operator.
Cold	∅	NA		
Hot	∅	NA		
Waste	∅	NA		
ELECTRIC :				
Power	NA			
Voltage	NA			
Gas:				
BTU	NA			
Con.	∅		mm	
ACCESSORIES:				
SPECIAL NOTE: Color and qty As Per operator.				
MAKE AND MODEL				
FRONTIER		NILKAMAL		
FLB-ROL 70		GMWBFC68BASE + WHEELS		

ITEM NO : EXT-04			AIR CURTAIN
SIZE			IMAGE FOR REPRESENTATIVE PURPOSE ONLY
Width: 1500 mm	Depth: 208 mm	Height: 235 mm	
CAPACITY			
M.E.P REQUIRMENT		SPECIFICATIONS	



COMMERCIAL KITCHEN DESIGNERS

PLUMBING :				<ul style="list-style-type: none"> • Unit suitable for mounting on door opening & height As per plan & site. • S.S cover made for high-strength aluminum & engineering plastics • Air guide bar • Operated either by remote control or at the touch of a button. • Three speed switch functions low, medium & high speed. • Adopting optimized electrical machinery • Maximum velocity at the nozzle to be approx 18 m/s
Cold	∅	NA		
Hot	∅	NA		
Waste	∅	NA		
ELECTRIC :				
Power	0.5 H.P			
Voltage	220v.50c.1p			
Gas:				
BTU	NA			
Con.	∅	NA		
ACCESSORIES:		Power cord, Complete with mounting arrangement.		
SPECIAL NOTE:				
MAKE AND MODEL				
		TECHNOCRAT		
		SLEEK		

ITEM NO: EXT-03			INSECT- O- CUTOR
SIZE			IMAGE FOR REPRESENTATIVE PURPOSE ONLY
Width:	Depth:	Height:	



COMMERCIAL KITCHEN DESIGNERS

CAPACITY						
M.E.P REQUIREMENT			SPECIFICATIONS			
PLUMBING :			<ul style="list-style-type: none"> • Twin tubes. • Unit suitable for ceiling suspension or mounting on wall, • A proven approach to killing flies, conveniently and hygienically. • Unit with plastic coated M.S. guards provided • Attracts and trap flying insects permanently on replaceable Glue board. 			
Cold	∅	NA				mm
Hot	∅	NA				mm
Waste	∅	NA				mm
ELECTRIC :						
Power	0.5 H.P.					
Voltage	220V.50V.1p					
Gas:						
BTU	NA					
Con.	∅		mm			
ACCESSORIES:			Power cord , Mounting bolts			
SPECIAL NOTE:						
MAKE AND MODEL						
TECHNOCRAT						

BAR



COMMERCIAL KITCHEN DESIGNERS

Work Table With Cross Bracing

Item Number: - BR-04

Over All Size: - 1350 x 520 x 900 + 50

QTY: - 1 No.

Item Number: - BR-06

Over All Size: - 950 x 520 x 900 + 50

QTY: - 1 No.

Item Number: - BR-07

Over All Size: -

QTY: - 1 No.

Item Number: - BA-23

Over All Size: - 1300 x 600 x 900 + 50

QTY: - 1 No.

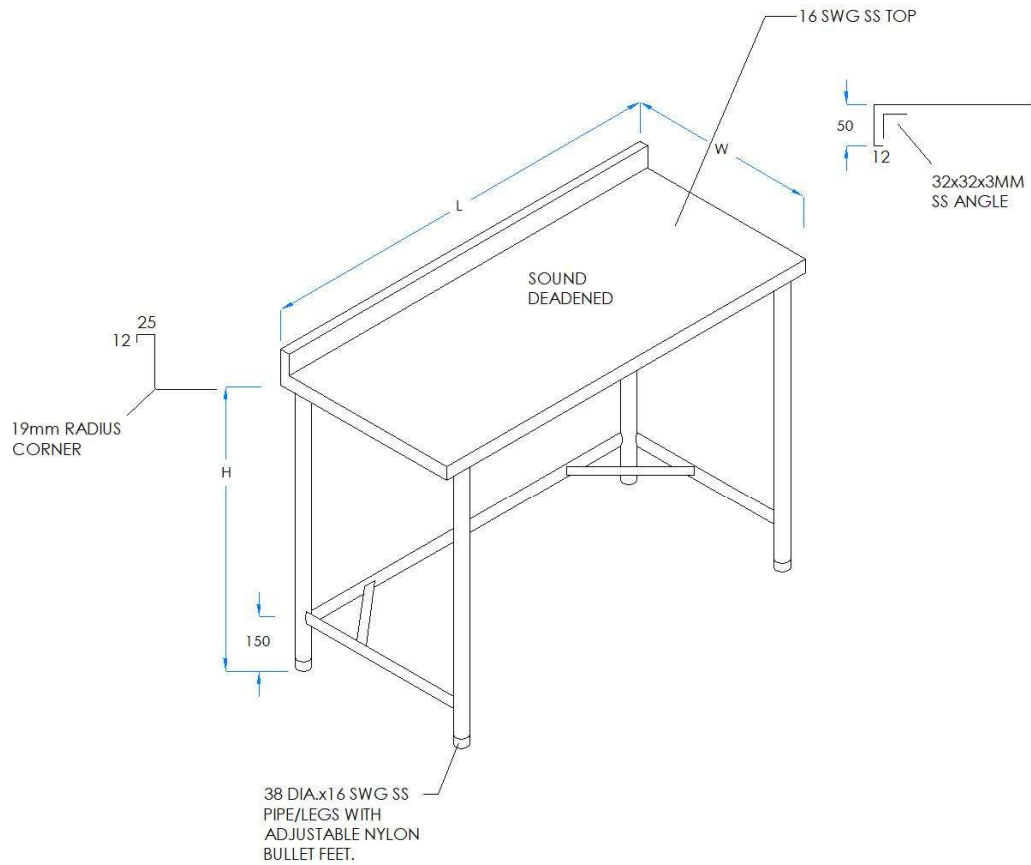

Work Table With Sink (Sink on LHS)



COMMERCIAL KITCHEN DESIGNERS

Over All Size:- 1265 x 600 x900 + 50

Qty:- 1 Number each

Item Number:- BA-09

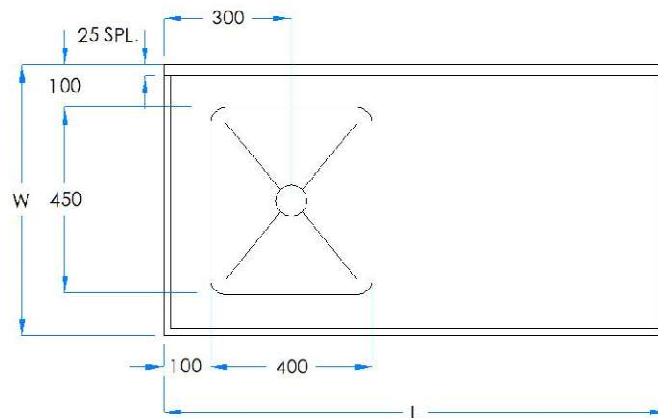
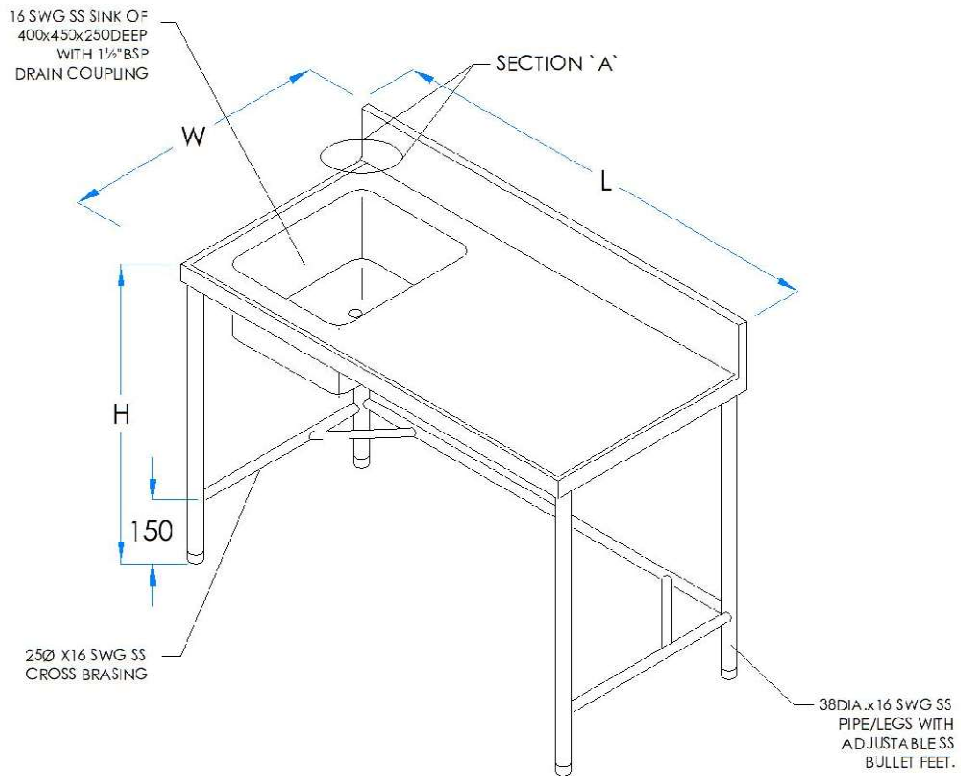

SIDE TABLE



COMMERCIAL KITCHEN DESIGNERS

Over All Size:- 525 x 525 x 900 + 50

Qty:- 1 Number

Item Number:- BA-19

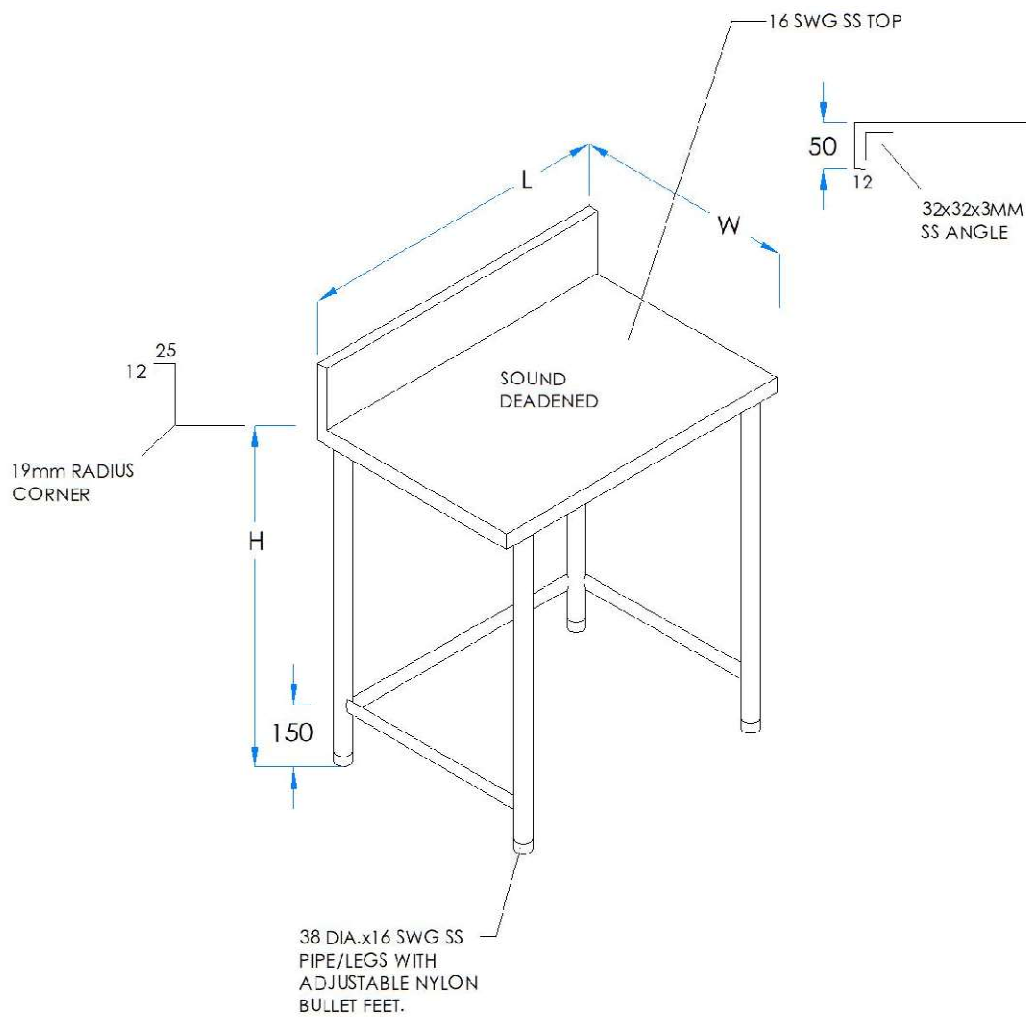



COMMERCIAL KITCHEN DESIGNERS

ITEM NO : BAR - EXT-01			Water Boiler (Geyser)		
SIZE ALL SIZES IN MM			IMAGE FOR REPRESENTATIVE PURPOSE ONLY		
Width:	Depth:	Height:			
CAPACITY 3 Liters Capacity					
M.E.P REQUIRMENT			SPECIFICATIONS		
PLUMBING :			<ul style="list-style-type: none"> STANDARD 		
Cold	∅	12			
Hot	∅	NA			
Waste	∅	NA			
ELECTRIC :					
KW	2				
Phase	220v.50c.1p				
Gas:					
BTU	NA				
Con.	∅	NA			
ACCESSORIES:			Power cord, Complete with mounting arrangement.		
SPECIAL NOTE:					
MAKE AND MODEL					
RACOLD					