



LEGEND'S:

S.N.	DESCRIPTION	SYMBOL
01.	HYDRANT PIPE	
02.	INTERNAL DRAIN PIPE	
03.	FIRE SPRINKLER PIPE	
04.	CEILING PENDANT SPRINKLER	
05.	HOSE DRUM	
06.	NOZZALE	
07.	FIRE EXTINGUISHER K TYPE-6KG	
08.	FIRE EXTINGUISHER CO2-5KG	
08.	FIRE EXTINGUISHER ABC-6KG	
10.	MANNUAL CALL POINT	
11.	HOOTER	

PROJECT LOCATION

BLOCK
BLOCK

- General Notes**
- All dimensions are in millimeters.
 - Dimensions are to be read and not to be scaled.
 - The contractor must verify all dimensions on site and refer the relevant STRUCTURAL and other MEP drawings before commencing any work or preparing shop drawings, and in case any discrepancy is noticed the same shall be brought to the notice of the architect and shall be clarified before execution of work.
 - Refer this drawing along with the other relevant architectural, structural and MEP services drawings.
 - All Sill & Lintel levels to be considered from FFL

**ORDINARY HAZARD PIPE SCHEDULE:
(AS PER IS-15105:2002 GUIDELINES)**

PIPE DIA.	NO. OF SPRINKLER
25Ø	2 SPRINKLER
32Ø	3 SPRINKLER
40Ø	5 SPRINKLER
50Ø	10 SPRINKLER
65Ø	20 SPRINKLER
80Ø	40 SPRINKLER
100Ø	100 SPRINKLER
125Ø	160 SPRINKLER
150Ø	275 SPRINKLER

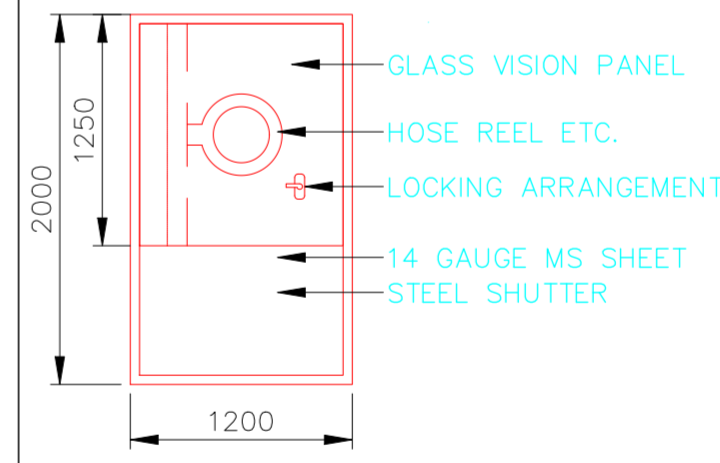

TYPICAL INTERNAL HYDRANT ENCLOSURE DETAILS

LEGEND'S:

FIRE QUANTITY

S.N.	SYMBOL	LENGTH
01.		125 METER
02.		10 METER
03.		25 METER
04.		28 METER
05.		17 METER
06.		07 METER
07.		13 METER

80 SPRINKLER

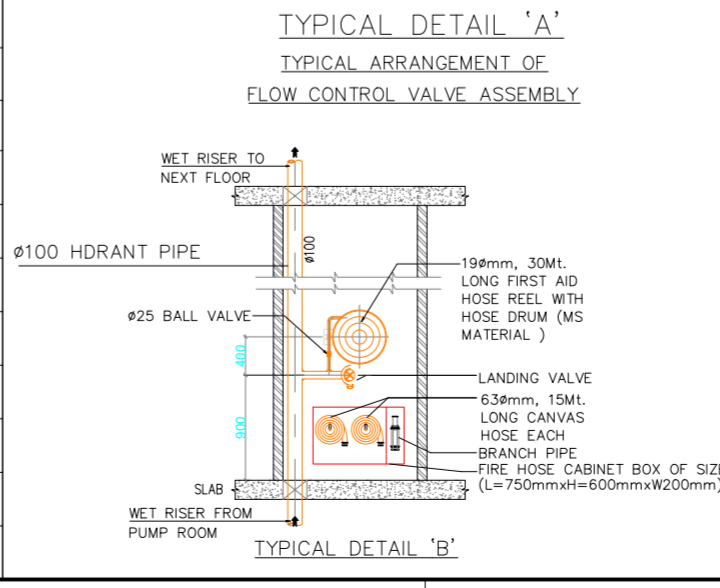

TYPICAL DETAIL 'A' TYPICAL ARRANGEMENT OF FLOW CONTROL VALVE ASSEMBLY

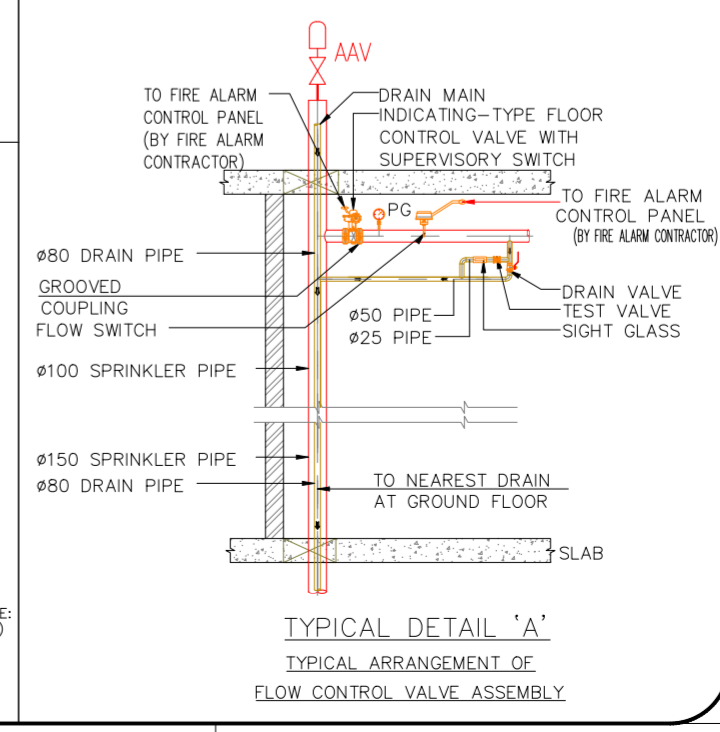

TYPICAL DETAIL 'A' TYPICAL ARRANGEMENT OF FLOW CONTROL VALVE ASSEMBLY

MEP CONSULTANTS:
PILLARPLUS PVT LTD-The New Age MEP Consultancy Firm
Plot No. 45, 46 guru Jambheshwar Nagar A,
Vijay Dwar, Gandhipath, Jaipur-302021
PillarPlus JAIPUR | GURGAON | BANGLORE
Email: contact@pillarplus.com | Contact No: +91-9799858301 | Website: www.pillarplus.com

Rev.	Date	Description	Approved

CLIENT
ADDRESS

ARCHITECTS
PLUGD
Ar. Ritika Malik & Ar. Sourabh Khurana
1st Floor, C-78, Sector-88, Noida - 201305

DRAWING TITLE
FIRST FLOOR FIRE FIGHTING PLAN

FOR TENDER	DATE	PROJ ARCHITECT
<input type="checkbox"/>	19-12-2024	PROJ ARCHITECT
<input checked="" type="checkbox"/>	SCALE	DRAWN
<input type="checkbox"/>	SCALE	CHECKED
<input type="checkbox"/>	SCALE	WASEEM NOOR

DRAWING NO. REVISION NO.

PLUGD
C-78, Sector 88, Noida-201305
The contents of this drawing constitute the original and unpublished work of PLUGD and no part of the drawing shall be disclosed / modified / used in any manner without their prior consent.