



# COMMERCIAL KITCHEN DESIGNERS

16, Kadambari, Devi Chowk, Shastri Nagar  
Dombivali (East) – 421204, Mumbai

DATE:

QTY:

PRODUCT:

OVERALL SIZE:- 1200 x 700 x 500

LENGTH x WIDTH

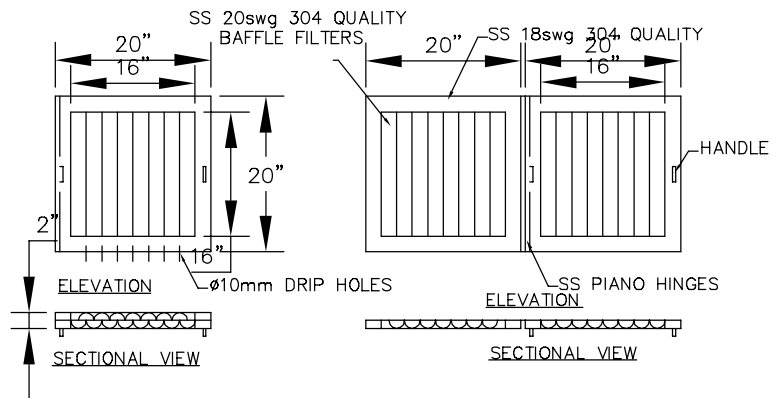
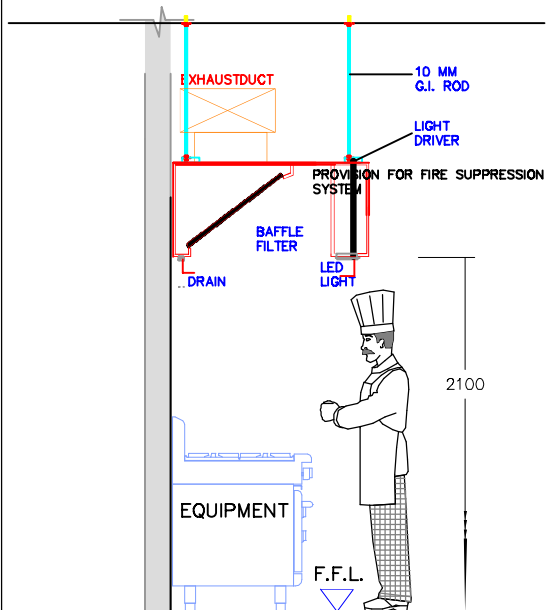
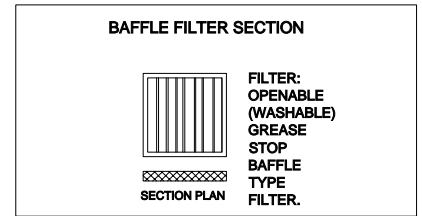
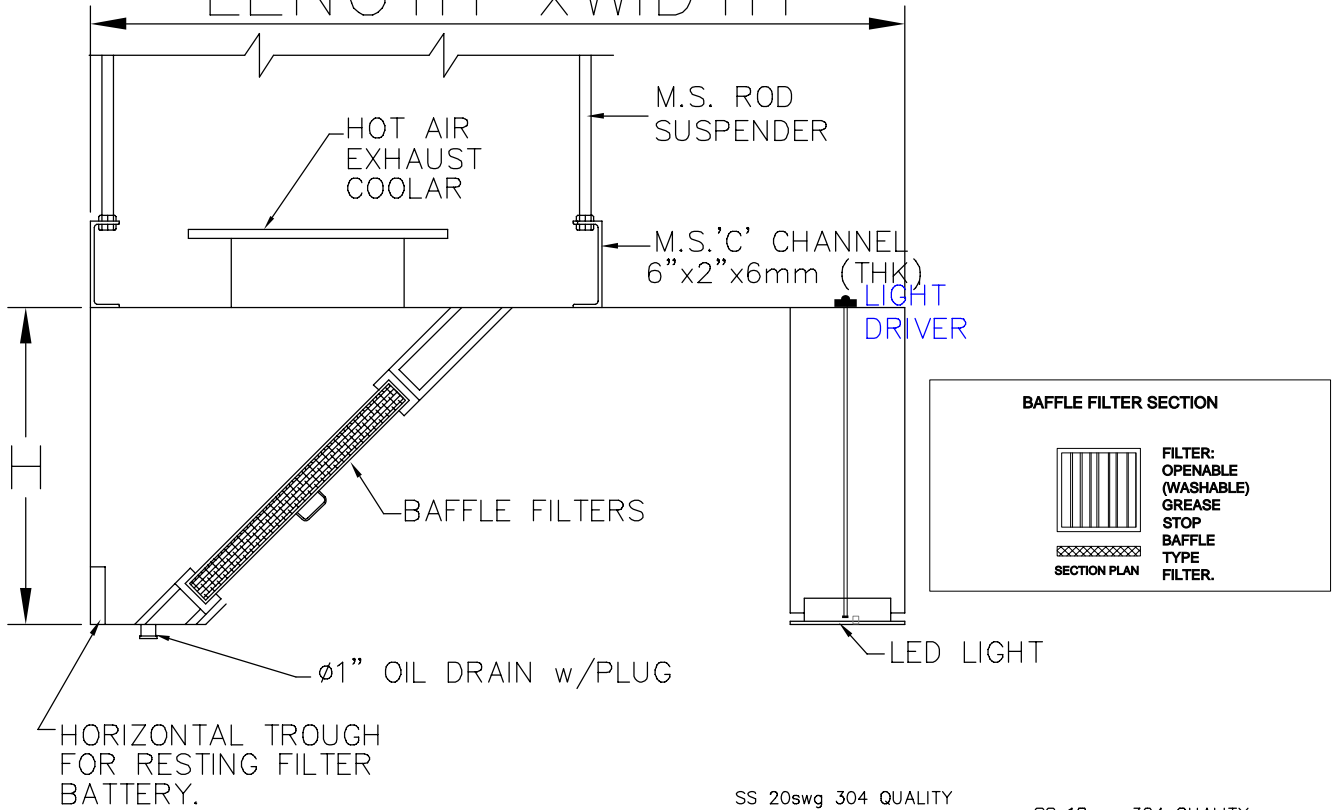

- 1) Hoods would be manufactured in 18g SS304 and hoods filters openable baffle type
- 2) Baffle filters should be in SS 304 and filter size should be of size 500x500mm. And end piece of filter can be adjusted as per the space available.
- 3)Hoods would be supplied with removable,Washable SS Grease Filters.
- 4)Hoods would be supplied with LED lights with cover in square shape.
- 5)Both sides at bottom ss grease drawer required
- 6) Fully welded Joints.
- 7) All corners should be Argon welded and Finished neatly.
- 8) Need to provide provision for fire supression
- 9)Cutouts for exhaust /fresh air collar has to be done at site with co ordination of ducting person.
- 10) Hoods to be installed as per site condition
- 11) Need to do site visit prior to fabrication of exhaust hoods
- 12) HOODS WILL BE FABRICATED IN PARTS

SPECIAL INSTRUCTION:-

REV:-

DATE: