

COMPANY NAME: TRAVEL FOOD SERVICES PVT. LTD.
TENDER DOCUMENT FOR IOCL MANESAR TRUCKER'S
DHABA KITCHEN EQUIPMENT

1. GENERAL TERMS AND CONDITIONS

2. GENERAL METAL SPECIFICATIONS

3. INDIVIDUAL EQUIPMENT SPECIFICATIONS

4. BOQ OF KITCHEN EQUIPMENT

5. KITCHEN LAYOUT

GENERAL TERMS AND CONDITIONS

Prices:

- Quoted prices shall be in Indian Rupees.
- Prices quoted should be basic ex-factory prices.
- All other additional Extras to be mentioned separately.

Delivery:

- Tenderer shall clearly indicate the production time required for the said volume of the order in terms of weeks from the date or receipt of order.
- Delivery of material induces responsibility of off-loading the goods and shifting the goods at the location of installation.

Site Study / Measurement:

It will be responsibility of the Tenderer to take site visit for its study and detail measurement before starting the manufacturing of the equipment and co-ordinate with the consultant for smooth progress of the work. Fitting of equipment in to given locations will be total responsibilities of the manufacturer which must be noted. Oversized and / or undersized equipment due to site conditions will be rejected and appropriate size of product shall be fabricated by the supplier at his cost.

Samples of fittings:

To be used like Handles; locks; faucet hinges etc. Shall be sent for an approval of the consultant prior to use.

Approval of Shop Floor Drawings:

All the Individual Drawings should be sent to consultant for his approval. All the Drawings wherever changes are indicated by the consultant shall be rectified and sent back to the consultant for his approval.

Midway Inspection:

Though it is not insisted, it will be in the interest of the supplier to organize midway inspection by consultant to avoid changes on completed products. Expenditure for this Inspection shall be to Supplier's Account.

Final Inspection:

On completion of the final products supplier shall organize for Factory Inspection of all the products prior to dispatch. Expenditure for this Inspection shall be to Supplier's Account.

Commissioning:

Supplier shall organize for complete manpower for Commissioning and expenditure for lodging boarding shall be to Supplier's Account.

Penalty Clause:

Delivery period being essence 2% of the order value shall be charged for every day's delay as penalty and shall be adjusted in the final Bill.

Deviation to Specifications:

Any deviation to the specifications given in tender document must be clearly listed out point wise on separate sheet, in following format.

ITEM'S NUMBER AND NAME	TENDER SPECIFICATION	OFFERED SPECIFICATIONS

Payments Terms:

- 25% Advance against Bank Guarantee.
- 50% Against Delivery of complete order at site.
- 20% Against Commissioning.
- 05% After 6 months of working.

Spare Parts:

Supplier should provide recommended list of spare for 1st year with quantity and shall quote for it separately.

AMC Contract:

Tenderer shall send along with this offer a separate offer for comprehensive AMC contract of products supplied for three years on completion of the guarantee period.

Client :

Reserves the rights of accepting the tender in part or rejecting it fully without giving any reasons.

GENERAL METAL SPECIFICATIONS FOR KITCHEN EQUIPMENT

TOPS:

Made of 16 swg. 304 Quality 18/8 Grade Stainless Steel duly 120 Grit matt polished with all resulting edges rounded with no bur or other excess material left. Top will be turned down 50mm and 12mm underneath in channel shape on all exposed sides, in case of sunk in tops wherever mentioned the sides shall be raised by 20mm on all exposed sides, where tables are placed against walls, they will be turned up at back approximately 100/150mm splash back returned 25mm at 45° to wall with all exposed ends closed, argon arc welded and smooth polish.

UNDERSIDES:

Undersides of all Stainless Steel Tops for Table Counters, Sinks, Dish and Pot Tables will be mounted on 30mm x 30 mm x 5mm Stainless Steel Angle frame work with cross supports at maximum of 750mm span, duly secured by welding. The underside will be suitably sound deadened by treating with a coat of aluminum carboxide rubberized paint, finished with silver paint.

UNDERSHELVES:

Under shelves wherever called for will be constructed of 18 swg 304 Quality Stainless Steel Sheet uniformly matt polished with 120 Grit and reinforced with 30mm x 30mm x 3mm Stainless Steel angle frame. All shelves will be turned down 38mm and 12mm underneath on all sides with resulting corners cutout to fit contour of leg. Shelves for Hot case will be perforated.

FRAMEWORK:

Units with side panels shall have framework of **30mm x 30mm x 3mm Stainless Steel Angles** maximum distance will be 750mm.

LEGS/UPRIGHTS:

All Legs/Uprights will be constructed of 38mm Ø 16 swg Stainless Steel 304 B salem quality tubes spaced not more than 1800mm on center. All Legs will be fitted with Ferro nylon adjustable to approximately 30mm Height. Units more than 1800 mm in length will have 3 pairs of Uprights.

CROSS BRACINGS:

Front to back forming a 'H' frame wherever required will be constructed of 25mm Ø mm 16 swg Stainless Steel 304 tubes. All Cross Bracings will run horizontal and level between all legs approximately 150mm above floor level. All joints will be completely welded around entire perimeter forming a complete seal, with all welds ground and polished to match adjacent work.

SINKS:

All Sinks will be constructed of 16 swg 304 quality Stainless Steel with radius corners, argon arc welded, smooth ground and uniformly finished, duly fitted with 38 mm Ø BSP drain coupling and 1½" BSP Ball Valve, and /OR faucet as mentioned in Individual Input listing.

STAINLESS STEEL STORAGE RACK:

Shelves will be made of 18 swg 304 Stainless Steel Sheeting. The Rack will have number of shelves as specified in the description and reinforced with 25mm x 100mm x 25mm inverted 16 Swg Stainless Steel channel. Uprights of 38mm Ø x 16 swg Stainless Steel pipes fitted with nylon bullet feet.

BAIN MARIEWATER CHAMBER AND GN PANS.:

Made from 18 swg Stainless Steel 304, radius corner construction argon arc welded fitted with 25 mm Ø BSP lever operated drain valve for easy drain out and provided with cavity to house water immersion heater for efficient heating & duly insulated suitably. The unit will have a water sensor. The G/N pan used will be Imported and each with flat lid. (if possible to have cut for ladle)

INTERIOR OF HOT CABINET/PLATEWARMER:

All vertical interior panels of Hot Cabinet's and Plate Warmers will be constructed of 20 swg 304 Quality, 18/8 Grade Stainless Steel double beeded panels duly insulated with 1" thick glass wool insulation with thermostatic control from 0-110° C. Thermostat is of EGO make (Germany) miniature circuit breaker is to be used for protection. The control panel is die pressed and to be flush with the front. The heating elements at the bottom shall be covered with full size stainless steel perforated panel.

SLIDING DOORS:

Wherever provided to Ambient Cabinets as Non - Insulated the same will be constructed of 18 swg Stainless Steel 304, beeded panels and Insulated doors will be constructed of 20 swg Stainless Steel 304, beeded sandwiched panels duly mounted on top hung easy rolling nylon rollers and Stainless Steel guiding rails below.

BLINDER /ENCLOSURES:

Made of 20 swg Stainless Steel Sheeting uniformly polished and duly beeded from all sides.

OVERHEAD SHELVES:

Wherever provided will be made of 18 swg Stainless Steel 304 double beeded on all sides duly reinforced and fixed on 25mm x 25 mm 16 swg Stainless Steel pipes at the height specified and reinforced with 20mm x 60mm x 20mm 16 swg Stainless Steel channels.

WALL SHELVES:

Made of 18 swg Stainless Steel Sheet 304 with 25mm and 12mm double beeding all 3 sides and double beeded downwards at front duly secured with 16 swg Stainless Steel wall brackets. The brackets are fixed by anchor fasteners on wall.

WALL STORAGE CABINET:

Provided with of 18 swg Stainless Steel 304, Hinged Doors wherever mentioned not exceeding 400mm length. Doors shall be provided with pad lock facility. The construction shall be reinforced beeded panels and shall be fixable with anchor fasteners on wall.

FRONT/CONTROL PANEL:

All equipment will have the front panel made of 18 swg Stainless Steel 304, duly beeded and die pressed 20 swg Stainless Steel recessed control panel for safety operation, wherever provided.

SS POT RACK:

Sides and Uprights of 38 mm Ø Stainless Steel 304 pipes while Shelves made of 25 mm Ø Stainless Steel 304, pipes fitted at 100 mm C to C distance.

ELECTRICALS:

All electrically operated equipment will be thermostatically controlled with indicating bulbs duly fitted with best quality Brand Heaters or equivalent and heat resistant fiber coated copper wire. Miniature circuit breaker is used for protection of the equipment heaters. Electrical Hot Plates are manually controlled without thermostat.

GAS EQUIPMENT:

All gas equipment will be duly connected with best quality copper pig tails, needle valves and burners will be off heavy duty industrial type and to be operated at 0.3 kg /cm² (4.5 PSIG) gas pressure. The main line will be of 25 mm Ø BSP 'C' Class ERW M/ S Pipe and pressure tested. All gas equipment's will have pilot.

INSULATION:

All equipment will be suitably insulated with 25mm thick high quality mineral glass wool/asbestos/cerwool. Oven, bulk cookers will be insulated with 65mm thick glass wool.

ARGON WELDING:

Argon welding should be used for fabrication of equipment. The welded joints are smooth polished.

GRANITE TOPS:

Wherever called for will be of 20mm thick Black/White marble duly placed on neoprene rubber strips and framed with 16 swg Stainless Steel all sides to prevent slipping.

FREEZING EQUIPMENT





All frameworks will be Stainless Steel angle duly covered with 20 swg Stainless Steel Salem quality. Inner 22 swg 304 quality with PUF insulation fitted with Kirloskar hermetically sealed compressor.

FITTING

All nuts, bolts, screws to be of SS 304.

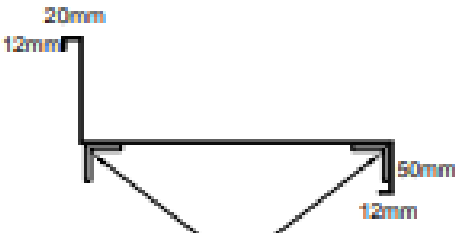
DETAILS OF ELECTRICAL, GAS & PLUMBING INPUTS TO BE USED

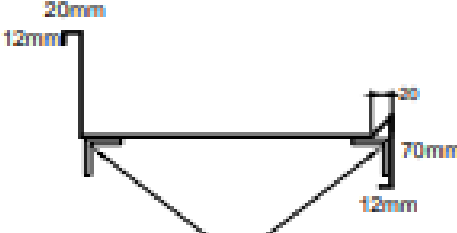
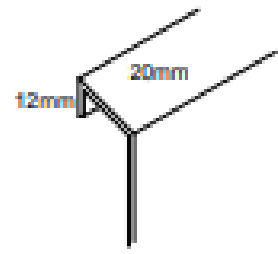
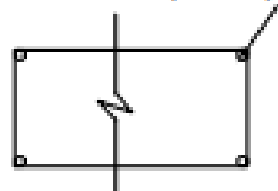
1	Water Immersion Heaters	:	Escort / Spot – Heat / Vileco (Girish Electricals)
2	Stainless Steel Tubing Oil Immersion Heater (Liftable)	:	S.V. Enterprise / Spot – Heat / Vileco (Girish Electricals)
3	Air Heater Encoly Tubing	:	S.V. Enterprise / Spot – Heat / Vileco (Girish Electricals)
4	Thermostat	:	EGO Make / Zumo
5	Rotary Switch	:	Thakur / Trinity Electricals / Kay Bee
6	Neon Indicating Lamps	:	S.V. Enterprise
7	Burners	:	Standard Make / United Make
8	Castors	:	Rexello Castors / Bombay Star
9	Compressors	:	Kirloskar Copeland / Shriram
10	Faucet	:	Jaquar / Cieko / ARK
11	Motor	:	Crompton / Siemens / New India / Hindustan / Kirloskar

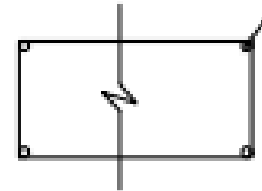
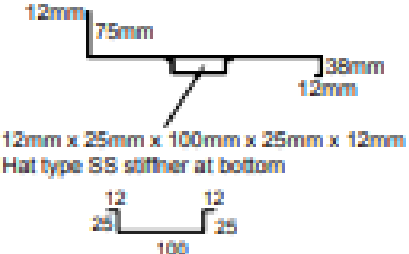
FABRICATED DETAILS SHEET	
WORK TOP DETAILS	
PLAIN TOP	PLAIN TOP WITH SPLASH DETAILS
 <p>35mm x 35mm x 3mm SS Angle Frame.</p>	 <p>35mm x 35mm x 3mm SS Angle Frame.</p>
SUNK IN TOP	SUNK IN TOP WITH SPLASH DETAILS
 <p>35mm x 35mm x 5mm SS Angle Frame.</p>	 <p>35mm x 35mm x 5mm SS Angle Frame.</p>
SPLASH DETAILS	UNDERSHELVES FIXING DETAILS
	<p>38mmØ x 16 swg SS pipe / legs with adjustable nylon bullet feet.</p>   <p>30mm x 30mm x 3mm SS Angle Frame.</p>
RACK SHELVES FIXING DETAILS	
<p>38mmØ x 16 swg SS pipe / legs with adjustable nylon bullet feet.</p> 	 <p>12mm x 25mm x 100mm x 25mm x 12mm Hat type SS stiffener at bottom</p>

**PRODUCT : TABLE TOP REFRIGERATOR WITH BAIN MARIE.
TABLE TOP REFRIGERATOR.
REFRIGERATOR PICK UP COUNTER.**

Note:- Please do not provide Build in Lock.
Provision for External Locking to be provided.



Locking Facility

FOOD WARMER:-

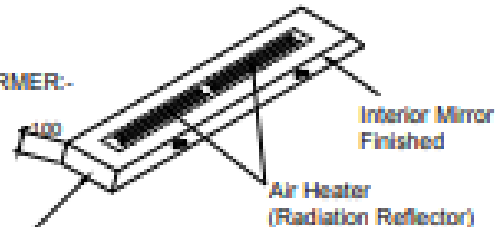

18 swg SS 304 grade R.R. with 750 watt. Air heater with toggle switch on both sides.

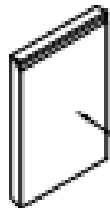

Door Design (Insulated)

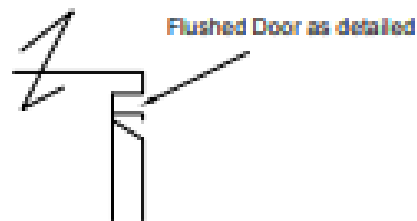

Flushed Door as detailed

Top:-	304 Grade, 18 swg Stainless Steel.
Refrigerated Pan:-	Double walled 20 swg Stainless Steel Coiled Pan.
Containers:-	Gastronom size as referred in Individual drawings.
Over Head Shelves:-	304 Grade, 18 swg Stainless Steel, double beaded on all sides duly reinforced and fixed on 25mm Ø, 16 swg Stainless Steel tubular pipes.
Food warmers:-	-
Outer/Inner Body:-	20/22 swg Stainless Steel.
Temp. Indicator:-	Special non- clogging electronic indicator with built in power supply with ON/OFF switch on the front panel of the compressor.
Temp. :-	4° to 8° Celsius.
Doors :-	304 Grade, 22 swg Stainless Steel, spring loaded, self closing door with magnetic gasket.
Insulation :-	PUF Insulation.
Refrigerant :-	R 134 A.
Refrigeration System :-	Hermetically sealed Kitoskar Copeland compressor with AUE fan motor.

Plain Top shall be Forced Draft Cooling Unit,
Unit with Refrigerated bain Marie shall have Static Cooling.

Pan resting :-	Made of 10mm x 15mm x 10mm, 18 swg Stainless Steel channel pairs with 15mm top edge cut to rest the pan before sliding. 6 pairs behind each door fitted equidistant on Stainless Steel channel for proper air circulation.
Base Frame:-	32mm x 32mm SS square pipes or 30mm x 30mm x 3mm SS Angle Frame (304 swg)
SS Rack:-	3 Nos. Stainless Steel racks of Stainless Steel rods provided in each compartment. sides and 2 cross supports of 6mm, while shelf of 4mm Stainless Steel rods.
Legs / Castors:-	150mm Ø Heavy Duty Rubberised Castors with Locking arrangement.

BACK SIDE PASSAGE

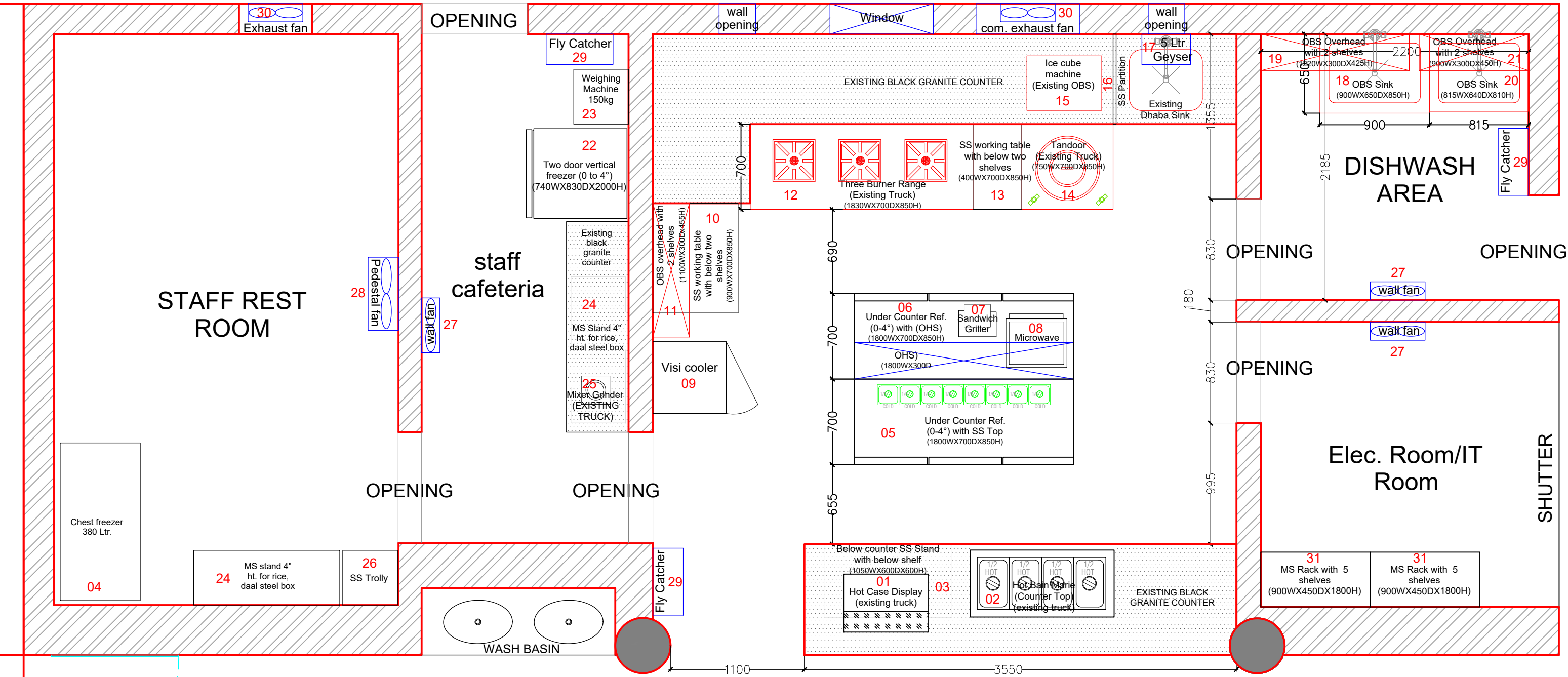

TRAVEL FOOD SERVICES

STATUS OF RELEASE: <input type="checkbox"/> FOR APPROVAL <input type="checkbox"/> FOR TENDER <input checked="" type="checkbox"/> FOR DISCUSSION <input type="checkbox"/> FOR CONSTRUCTION						STAMP: PROJECT NAME: GULLY KITCHEN LAYOUT		DRAWING TITLE: TRUCKER'S DHABA@IOCL MANESAR			
ARCHITECT NAME: TFS						CLIENT NAME:		NORTH DRAWING NO Rev.			
REV.	DATE	PREP BY	CHK BY	APPVD BY	REMARK	SCALE:		DATE	PREP	CHKD	APPVD
						25-06-2024		NIROJ SHRIWAL	CHEF VICKY		RITUPARN SHARMA

EQUIPMENT NO: 03

EQUIPMENT NAME: SS
STAND WITH BELOW SHELF

SIZE-: 1050WX600DX600HT.
QTY-: 01

BRAND: AS/SS
MANUFACTURER SPEC.

TOP MADE OF 16G SS304 SS SHEET
SPLASH OF ALL SIDES 50MM HIGH

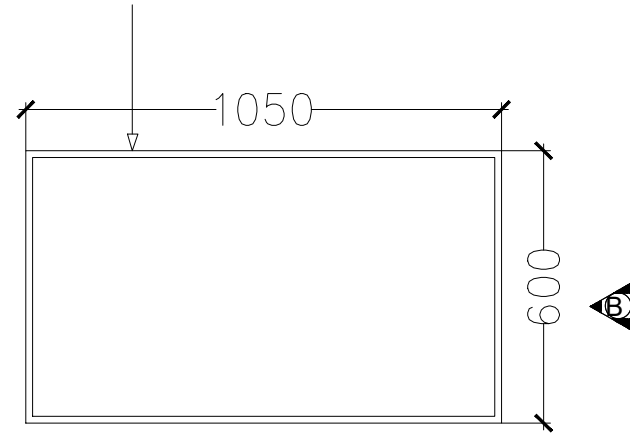

PLAN

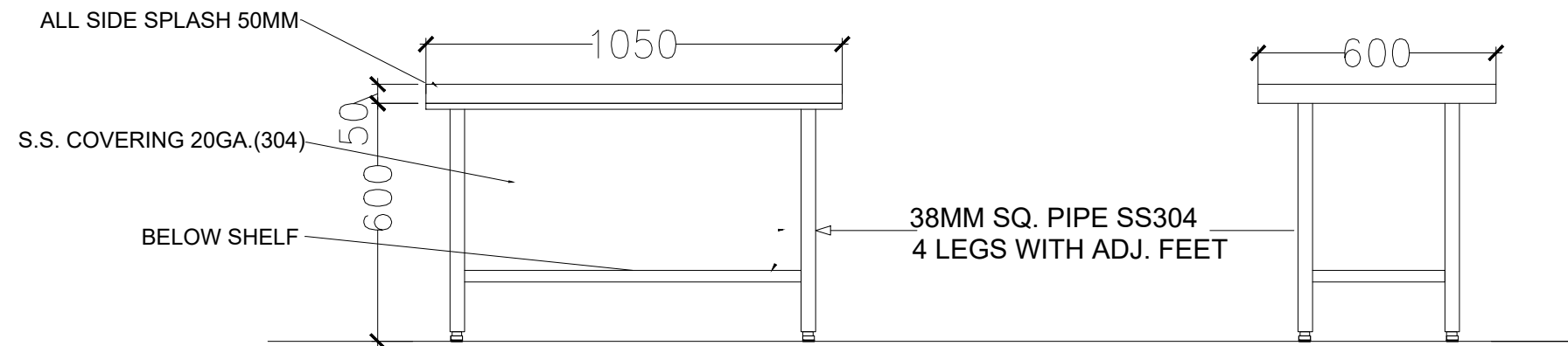

ELEVATION A

ELEVATION B



TRAVEL FOOD SERVICES

STATUS OF RELEASE:
 FOR APPROVAL FOR TENDER
 FOR DISCUSSION FOR CONSTRUCTION

REV.	DATE	PREP BY	CHK BY	APPVD BY	REMARK

STAMP:

PROJECT NAME:
EQUIPMENT DETAIL

CLIENT NAME:

ARCHITECT NAME:
TFS

DRAWING TITLE:
TRUCKER'S DHABA KITCHEN@IOCL MANESAR

NORTH	DRAWING NO	Rev.

SCALE	DATE	PREP	CHKD	APPVD
	19-07-2024	NIROJ SHRIWAL	CHEF VICKY	RITUPARN SHARMA

EQUIPMENT NO: 04

EQUIPMENT NAME: CHEST
FREEZER 380LTR.

MODEL-: CELFROST 380LTR.
QTY-: 01

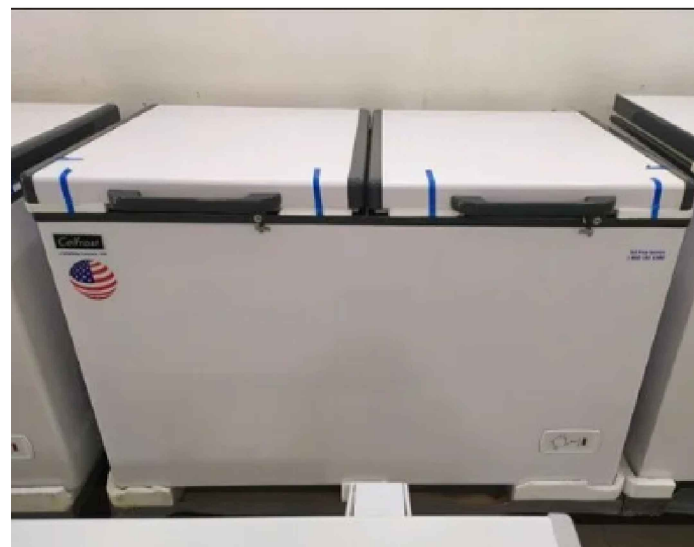
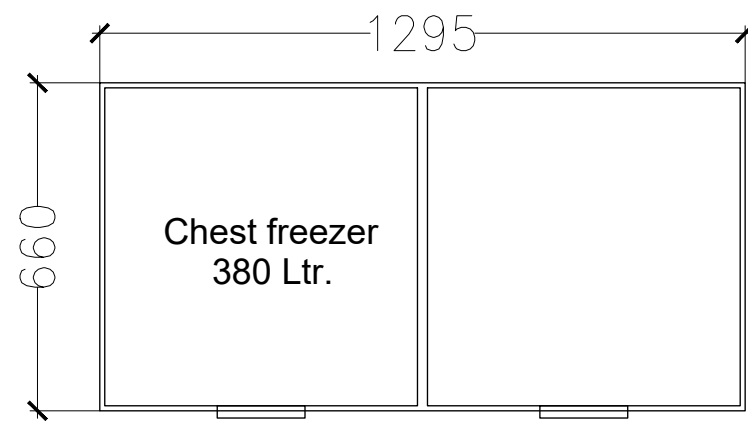

TRAVEL FOOD SERVICES

STATUS OF RELEASE:						STAMP:		DRAWING TITLE:									
<input type="checkbox"/> FOR APPROVAL						<input checked="" type="checkbox"/> FOR TENDER		PROJECT NAME:									
<input type="checkbox"/> FOR DISCUSSION						<input type="checkbox"/> FOR CONSTRUCTION		EQUIPMENT DETAIL									
						CLIENT NAME:		NORTH		DRAWING NO		Rev.					
						ARCHITECT NAME:		SCALE		DATE		PREP		CHKD		APPVD	
REV.						TFS				19-07-2024		NIROJ SHRIWAL		CHEF VICKY		RITUPARN SHARMA	

EQUIPMENT NO: 05

EQUIPMENT NAME: Under counter Refrigerator (0 to 4°) with 8no. 1/6 GN PAN

SIZE-: 1800WX700DX850HT.

QTY-: 01

BRAND: AS/SS

MANUFACTURER SPEC.

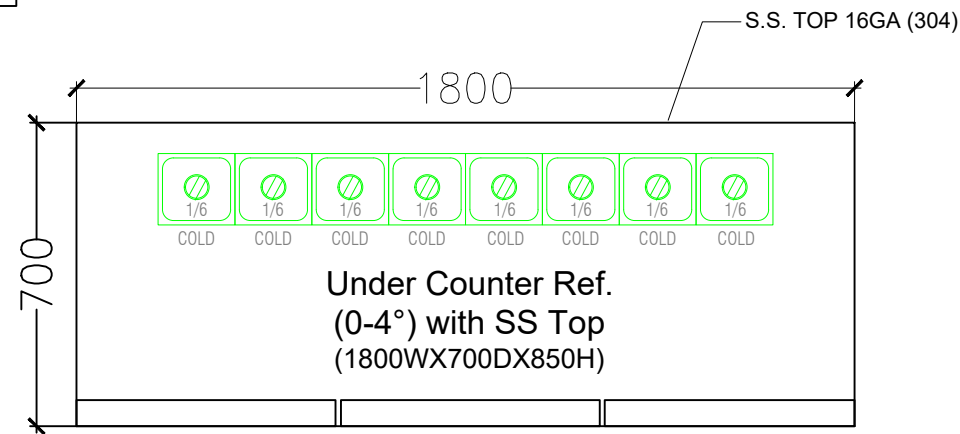

PLAN

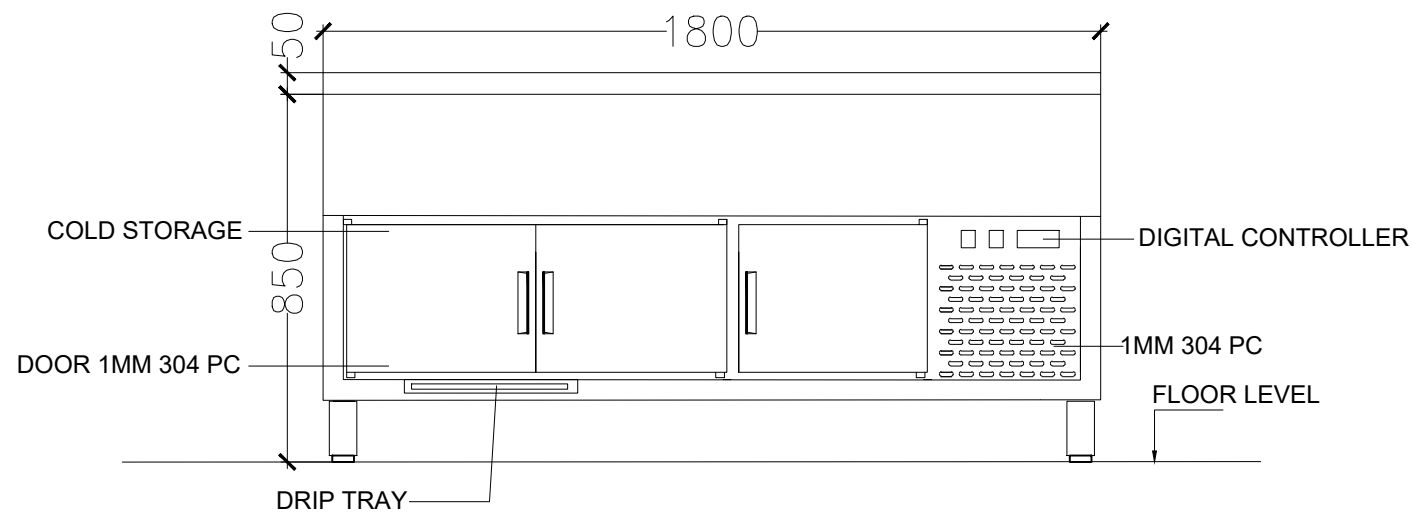
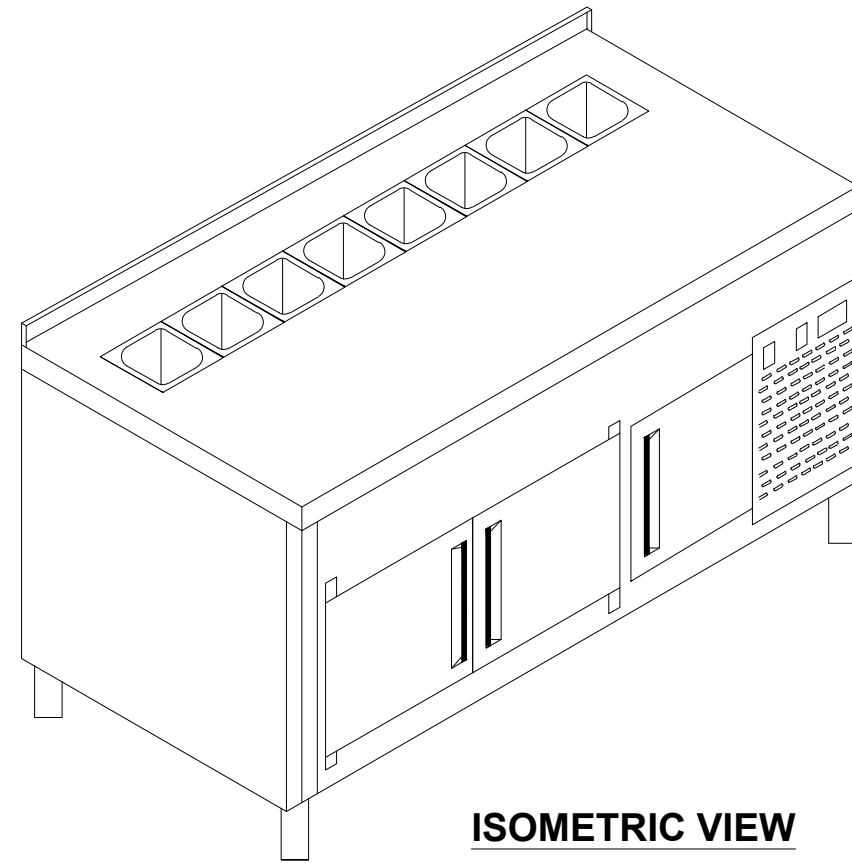

ELEVATION A-A



TRAVEL FOOD SERVICES

STATUS OF RELEASE:
 FOR APPROVAL FOR TENDER
 FOR DISCUSSION FOR CONSTRUCTION

REV.	DATE	PREP BY	CHK BY	APPVD BY	REMARK

STAMP:
 PROJECT NAME: EQUIPMENT DETAIL
 CLIENT NAME:
 ARCHITECT NAME: TFS

DRAWING TITLE: TRUCKER'S DHABA KITCHEN@IOCL MANESAR				
NORTH	DRAWING NO	Rev.		
SCALE	DATE	PREP	CHKD	APPVD
	19-07-2024	NIROJ SHRIWAL	CHEF VICKY	RITUPARN SHARMA

EQUIPMENT NO: 06

EQUIPMENT NAME: Under counter Refrigerator (0 to 4°) with Overhead Shelves (1800WX300D)

SIZE-: 1800WX700DX850HT.

QTY-: 01

BRAND: AS/SS

MANUFACTURER SPEC.

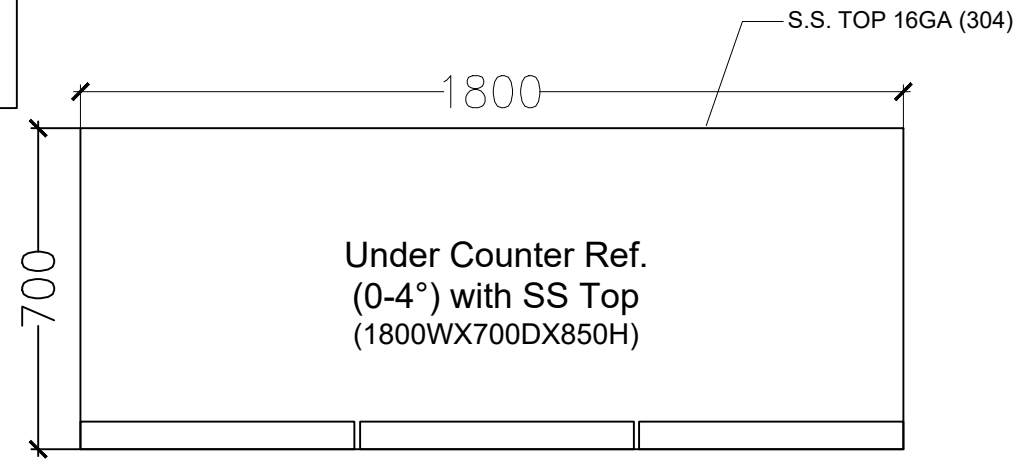

PLAN

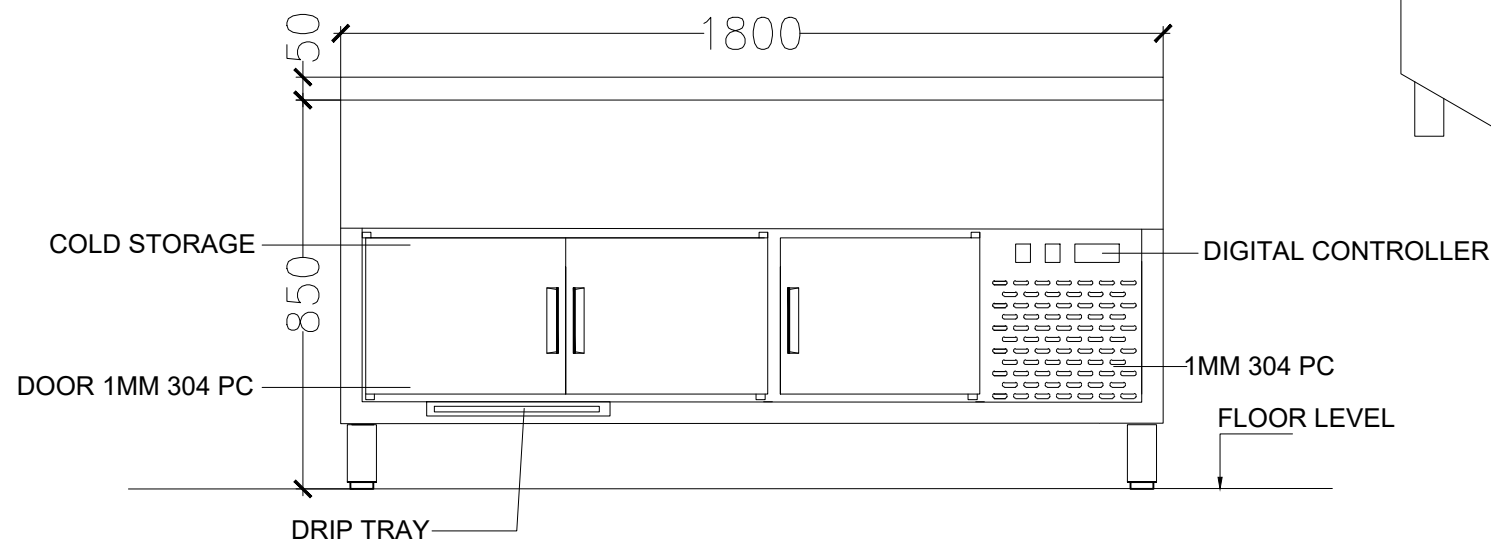

ELEVATION A-A

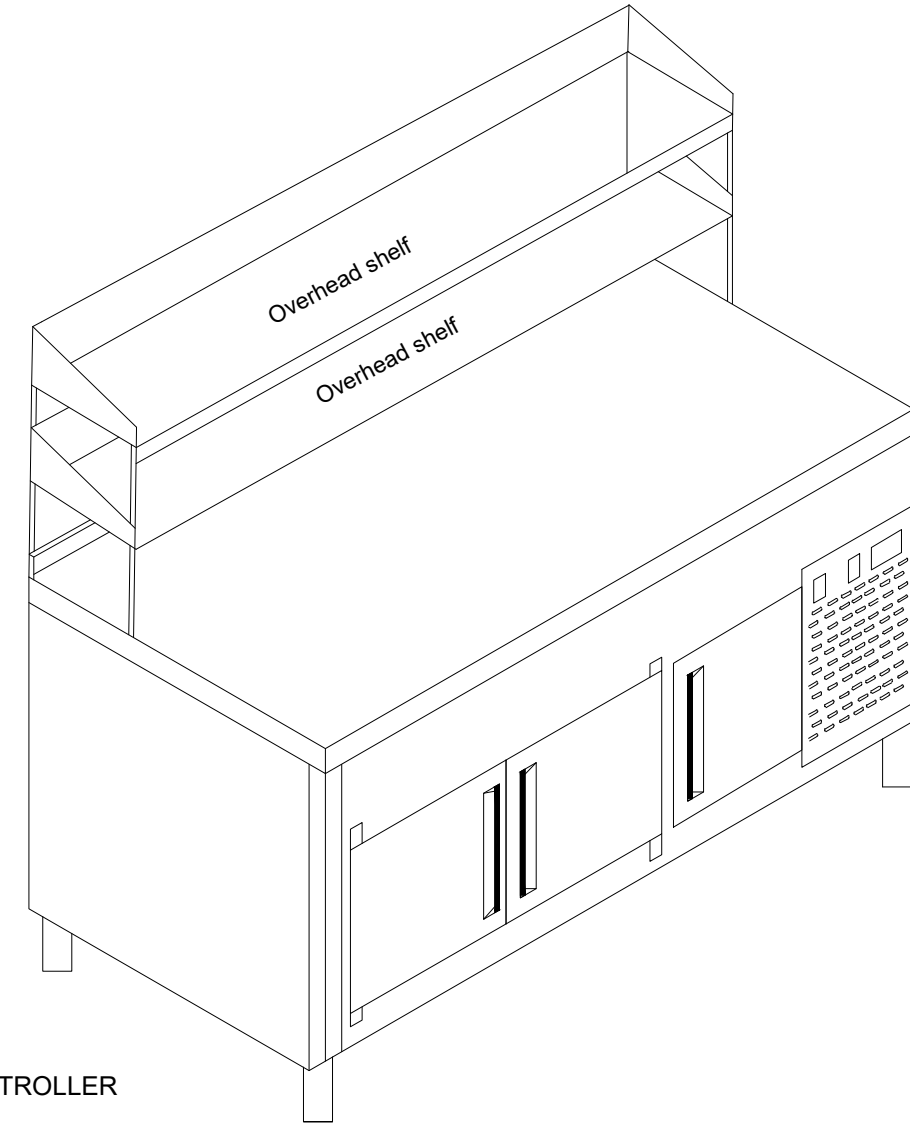

ISOMETRIC VIEW



TRAVEL FOOD SERVICES

STATUS OF RELEASE:
 FOR APPROVAL FOR TENDER
 FOR DISCUSSION FOR CONSTRUCTION

REV.	DATE	PREP BY	CHK BY	APPVD BY	REMARK

STAMP:

PROJECT NAME:
EQUIPMENT DETAIL

CLIENT NAME:

ARCHITECT NAME:
TFS

DRAWING TITLE:
TRUCKER'S DHABA KITCHEN@IOCL MANESAR

NORTH	DRAWING NO	Rev.

SCALE	DATE	PREP	CHKD	APPVD
	19-07-2024	NIROJ SHRIWAL	CHEF VICKY	RITUPARN SHARMA

EQUIPMENT NO: 07

EQUIPMENT NAME:
Sandwich Griller

SIZE-: AS/SPEC.

QTY-: 01

BRAND: KAMALAKSHI

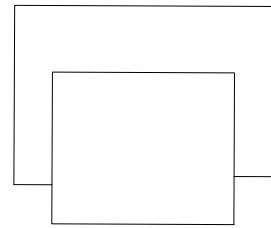

PLAN

EQUIPMENT NO: 08

EQUIPMENT NAME:
Microwave

SIZE-: as/spec.

QTY-: 01

BRAND: AS/Sel.
/CELFROST

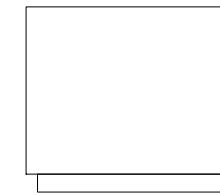

PLAN



TRAVEL FOOD SERVICES

STATUS OF RELEASE:

- FOR APPROVAL FOR TENDER
 FOR DISCUSSION FOR CONSTRUCTION

REV.	DATE	PREP BY	CHK BY	APPVD BY	REMARK

STAMP:

PROJECT NAME:
EQUIPMENT DETAIL

CLIENT NAME:
ARCHITECT NAME:
TFS

DRAWING TITLE:
TRUCKER'S DHABA KITCHEN@IOCL MANESAR

NORTH	DRAWING NO	Rev.

SCALE	DATE	PREP	CHKD	APPVD
	19-07-2024	NIROJ SHRIWAL	CHEF VICKY	RITUPARN SHARMA

EQUIPMENT NO: 09

EQUIPMENT NAME: VISI COOLER

MODEL NO.: AS/SELECTION

QTY:-: 01

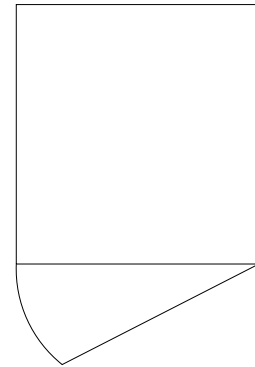

PLAN

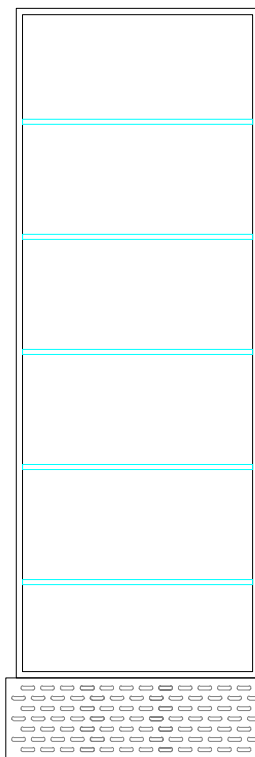

ELEVATION A

EQUIPMENT NO: 10

EQUIPMENT NAME: SS Work Table (below 2 shelves)

SIZE:-: 900WX700DX850HT.

QTY:-: 01

BRAND: AS/SS
MANUFACTURER SPEC.

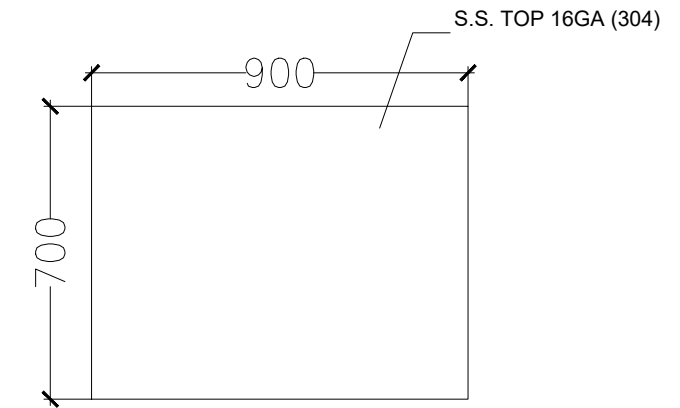

PLAN

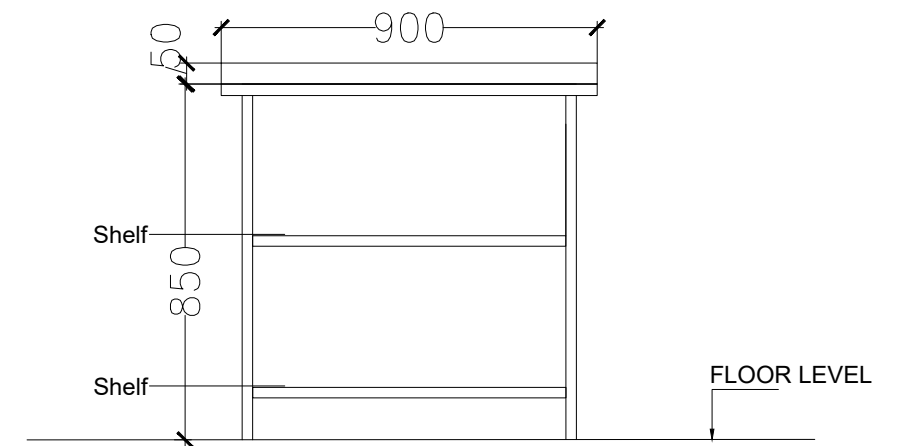

ELEVATION A



TRAVEL FOOD SERVICES

STATUS OF RELEASE:
 FOR APPROVAL FOR TENDER
 FOR DISCUSSION FOR CONSTRUCTION

REV.	DATE	PREP BY	CHK BY	APPVD BY	REMARK

STAMP:
PROJECT NAME:
EQUIPMENT DETAIL
CLIENT NAME:
ARCHITECT NAME:
TFS

DRAWING TITLE: TRUCKER'S DHABA KITCHEN@IOCL MANESAR				
NORTH	DRAWING NO	Rev.		
SCALE	DATE	PREP	CHKD	APPVD
	19-07-2024	NIROJ SHRIWAL	CHEF VICKY	RITUPARN SHARMA

EQUIPMENT NO: 13

EQUIPMENT NAME: SS
Work Table (below 2 shelves)

SIZE-: 400WX700DX850HT.

QTY-: 01

BRAND: AS/SS
MANUFACTURER SPEC.

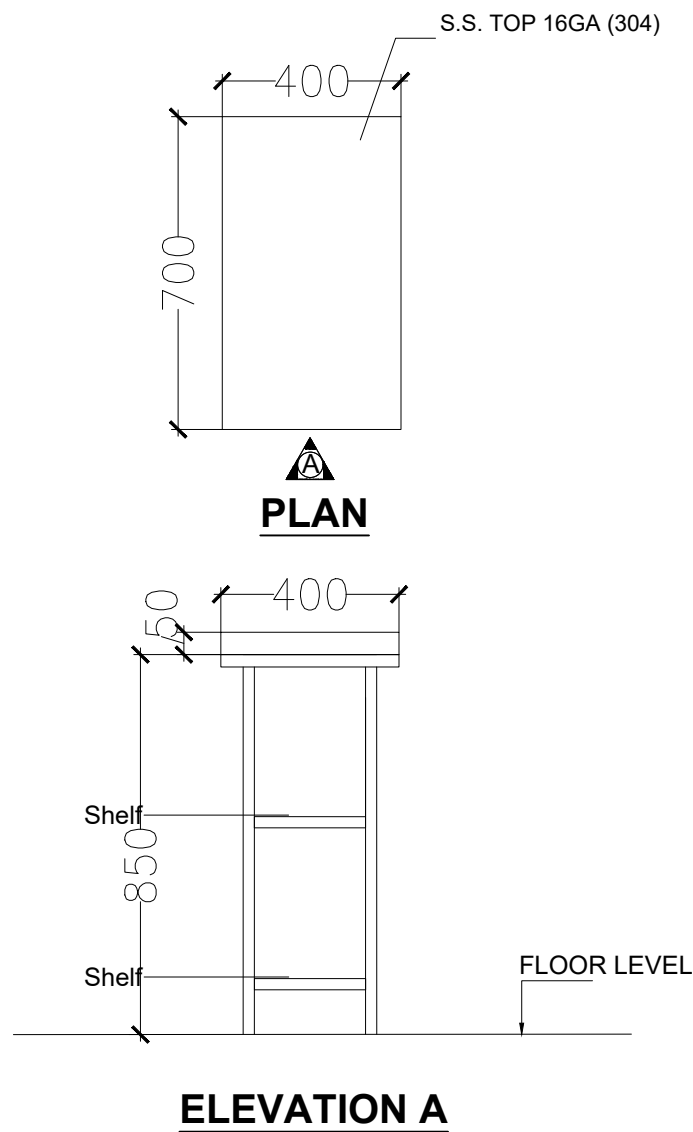

TRAVEL FOOD SERVICES

STATUS OF RELEASE:

- FOR APPROVAL FOR TENDER
 FOR DISCUSSION FOR CONSTRUCTION

REV.	DATE	PREP BY	CHK BY	APPVD BY	REMARK

STAMP:

PROJECT NAME:
EQUIPMENT DETAIL

CLIENT NAME:

ARCHITECT NAME:
TFS

DRAWING TITLE:
TRUCKER'S DHABA KITCHEN@IOCL MANESAR

NORTH	DRAWING NO	Rev.

SCALE	DATE	PREP	CHKD	APPVD
	19-07-2024	NIROJ SHRIWAL	CHEF VICKY	RITUPARN SHARMA

EQUIPMENT NO: 16

EQUIPMENT NAME: SS
PARTITION

SIZE-: 600WX300HT.

QTY-: 01

BRAND: AS/SS
MANUFACTURER SPEC.

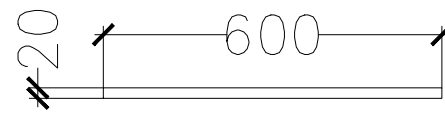

PLAN

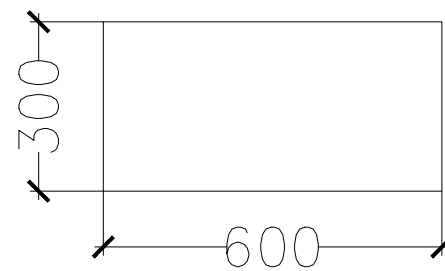

ELEVATION



TRAVEL FOOD SERVICES

STATUS OF RELEASE:

- FOR APPROVAL FOR TENDER
 FOR DISCUSSION FOR CONSTRUCTION

REV.	DATE	PREP BY	CHK BY	APPVD BY	REMARK

STAMP:

PROJECT NAME:
EQUIPMENT DETAIL

CLIENT NAME:

ARCHITECT NAME:
TFS

DRAWING TITLE:
TRUCKER'S DHABA KITCHEN@IOCL MANESAR

NORTH	DRAWING NO	Rev.

SCALE	DATE	PREP	CHKD	APPVD
	19-07-2024	NIROJ SHRIWAL	CHEF VICKY	RITUPARN SHARMA

EQUIPMENT NO: 22

EQUIPMENT NAME: Two Door
Freezer (0-4°) Temp.

SIZE-: 740WX830DX2000HT.

QTY-: 01

BRAND: CELFROST

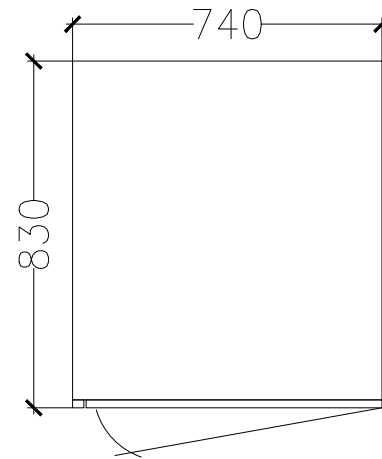

PLAN

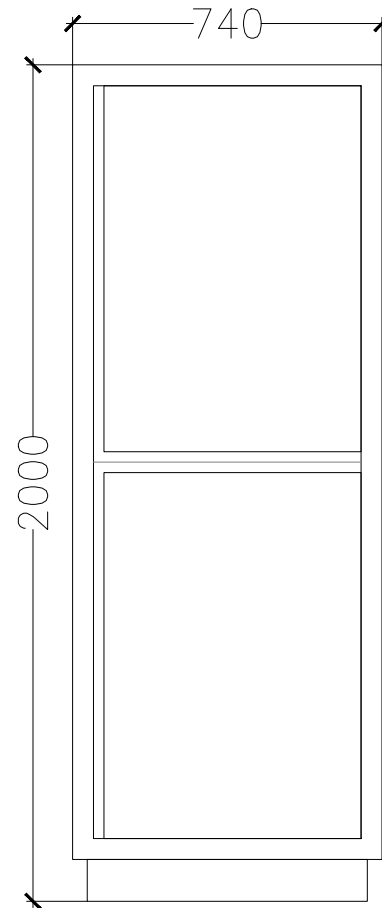

ELEVATION

EQUIPMENT NO: 23

EQUIPMENT NAME: Weighing
Machine (Cap. 150KG)

SIZE-: AS/SPEC.

QTY-: 01

BRAND: METIS

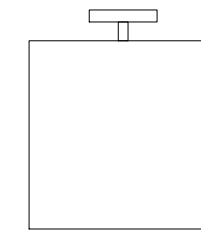

PLAN



TRAVEL FOOD SERVICES

STATUS OF RELEASE:

- FOR APPROVAL
- FOR TENDER
- FOR DISCUSSION
- FOR CONSTRUCTION

REV.	DATE	PREP BY	CHK BY	APPVD BY	REMARK

STAMP:

PROJECT NAME:
EQUIPMENT DETAIL

CLIENT NAME:

ARCHITECT NAME:
TFS

DRAWING TITLE:
TRUCKER'S DHABA KITCHEN@IOCL MANESAR

NORTH	DRAWING NO	Rev.

SCALE	DATE	PREP	CHKD	APPVD
	19-07-2024	NIROJ SHRIWAL	CHEF VICKY	RITUPARN SHARMA

EQUIPMENT NO: 24

EQUIPMENT NAME: MS
STAND

SIZE-: 1200WX450DX100HT.
QTY-: 02

BRAND: AS/MS
MANUFACTURER SPEC.

EQUIPMENT NO: 26

EQUIPMENT NAME: SS
TROLLY

SIZE-: 450WX450DX850HT.
QTY-: 01

BRAND: AS/SS
MANUFACTURER

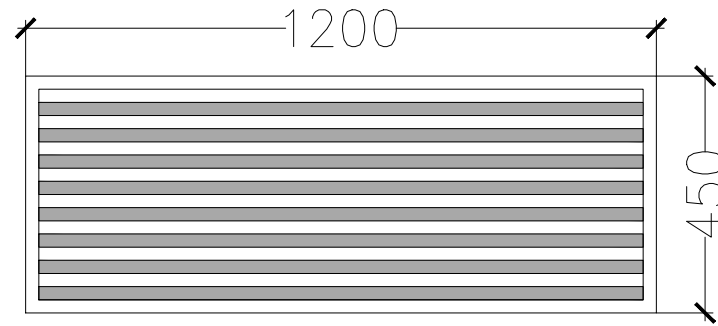

PLAN

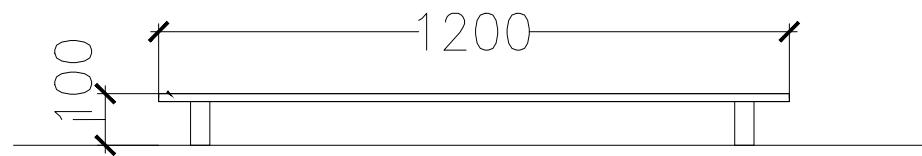

ELEVATION A

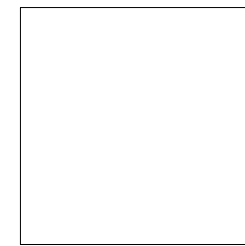

TRAVEL FOOD SERVICES

STATUS OF RELEASE:

- FOR APPROVAL FOR TENDER
 FOR DISCUSSION FOR CONSTRUCTION

REV.	DATE	PREP BY	CHK BY	APPVD BY	REMARK

STAMP:

PROJECT NAME:
EQUIPMENT DETAIL

CLIENT NAME:

ARCHITECT NAME:
TFS

DRAWING TITLE:
TRUCKER'S DHABA KITCHEN@IOCL MANESAR

NORTH	DRAWING NO	Rev.

SCALE	DATE	PREP	CHKD	APPVD
	19-07-2024	NIROJ SHRIWAL	CHEF VICKY	RITUPARN SHARMA

EQUIPMENT NO: BK-31

EQUIPMENT NAME: MS Powder coated Rack with 5 shelves

SIZE-: 900WX450DX1800HT.

QTY-: 02

BRAND: AS/MS

MANUFACTURER SPEC.

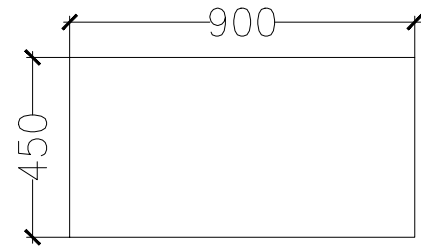

PLAN

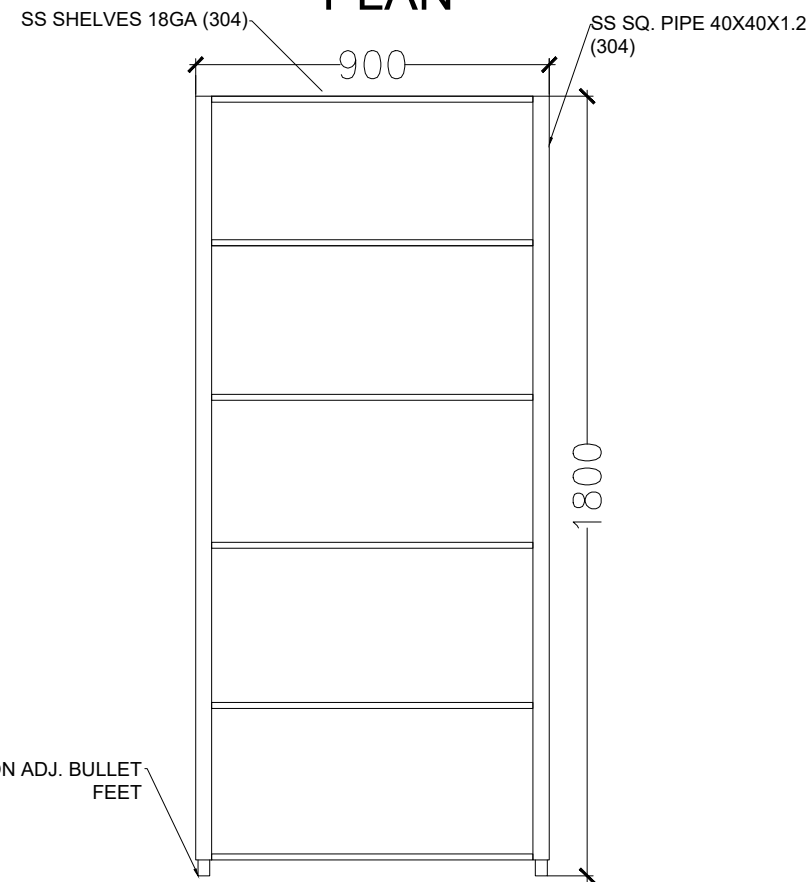

ELEVATION

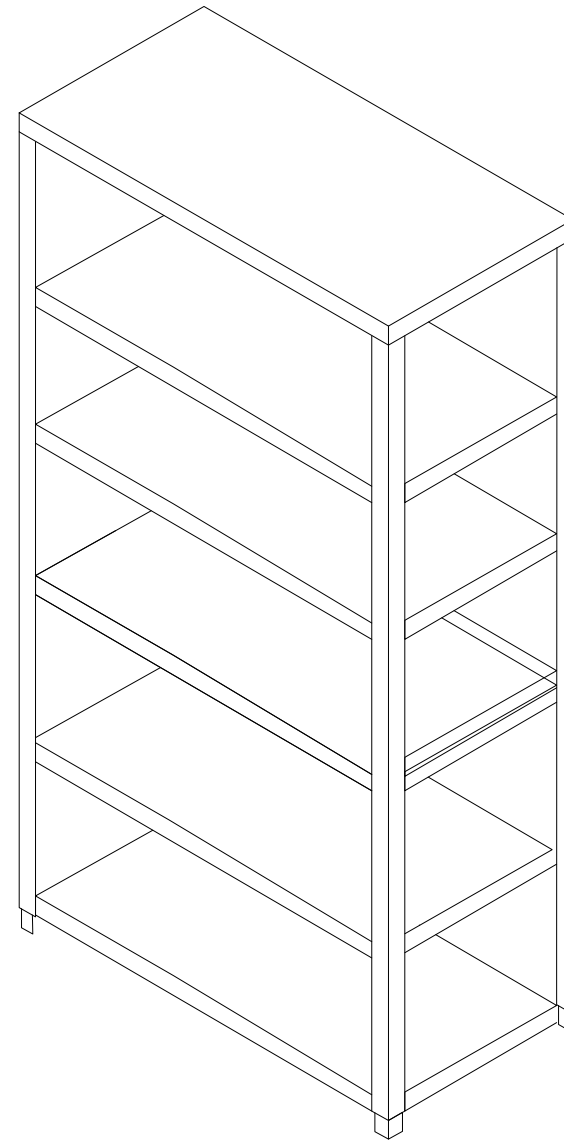

TRAVEL FOOD SERVICES

STATUS OF RELEASE:						STAMP:		DRAWING TITLE:						
<input type="checkbox"/> FOR APPROVAL						<input checked="" type="checkbox"/> FOR TENDER		TRUCKER'S DHABA KITCHEN@IOCL MANESAR						
<input type="checkbox"/> FOR DISCUSSION						<input type="checkbox"/> FOR CONSTRUCTION		NORTH		DRAWING NO		Rev.		
REV.						ARCHITECT NAME:		SCALE		DATE		PREP	CHKD	APPVD
DATE						TFS		19-07-2024		NIROJ SHRIWAL	CHEF VICKY	RITUPARN SHARMA		
PREP BY														
CHK BY														
APPVD BY														
REMARK														

TRUCKER'S DHABA KITCHEN @ IOCL MANESAR EQUIPMENT BOQ.

S. No.	Equipment	Dimensions	Qty	Category	Wattage(KW)	Elec. Point Ht.	Water supply Height	Drain	Gas & GLDS Point	Exhaust	REMARKS	Category
3	SS STAND WITH TWO SHELVES BELOW	1050Wx600Dx600H+50 HIGH	1	Fabrication								
4	CHEST FREEZER 380 LTR.	AS/SELECTION	1	Refrigeration	1	450MM/FFL						
5	UNDER COUNTER REFER TEMP (0-4°) WITH 8 1/6 GN PAN	1800Wx700Dx850H+50 HIGH	1	Refrigeration	4	1200MM/FFL						
6	UNDER COUNTER REFER TEMP (0-4°) WITH OHS (1800WX300D)	1800Wx700Dx850H+50 HIGH	1	Refrigeration	4	1200MM/FFL						
7	SANDWICH GRILLER (TABLE TOP)	AS/SELECTION	1	Boughtout	0.5	1200MM/FFL						
8	MICROWAVE	AS/SEL./CELFROST	1	Boughtout	0.5	1200MM/FFL						
9	VISI COOLER	AS/SELECTION	1	Refrigeration	2.5	1200MM/FFL						
10	SS WORKING TABLE WITH TWO SHELVES BELOW	900Wx700Dx850H+50 HIGH	1	Fabrication								
13	SS WORKING TABLE WITH TWO SHELVES BELOW	400Wx700Dx850H+50 HIGH	1	Fabrication								
16	SS PARTITION	600Wx300H	1	Fabrication			EXISTING	YES				
22	REACH IN FREEZER (TWO DOOR) (0 to 4°) TEMP	680Wx810DX1850H	1	Refrigeration	2	1500MM/FFL						
23	WEIGHING MACHINE (CAP.150KG)	AS/SEL./METIS	1	Boughtout	0.5	450MM/FFL						
24	MS STAND (LOW HT.) AS/SPEC.	1200Wx450DX100H	2	Fabrication								
26	SS TROLLY	450Wx450DX850H	1	Fabrication								
27	WALL FAN	AS/SEL.	3	Boughtout	0.5	1500MM/FFL						
28	PEDESTAL FAN	AS/SEL.	1	Boughtout	0.5	1200MM/FFL						
29	FLY CATCHER	AS/SELECTION	3	Boughtout	0.5	1500MM/FFL						
30	EXHAUST FAN (COMMERCIAL)	AS/SELECTION	3	Boughtout	0.5	1500MM/FFL						
31	MS RACK WITH 5 SHELVES	900Wx450DX1800H	1	Boughtout								
32	OGT	AS/SELECTION	1	OGT								
33	LONG BODY MIXER FOR DISHWASH SINK	AS/SELECTION	2	Boughtout								
34	SS DRAIN JAALI	300WX300D	2	Boughtout								
BOUGHT OUT ITEMS:												
1	PHILIPS T BEAMER 20W RECHARGEABLE EMERGENCY LIGHT, COOL DAY WHITE	AS/SELECTION	6	Boughtout	3							
TOTAL ELECTRIC LOAD (KW)					20							

NOTE:

- All the dimension needs to be physically measured at site by the vendor before commencing the production..
- G/N Pan Requirement will be shared by concerned brand.