



Travel Food Services

TRAVEL FOOD SERVICES

Shiv Sagar Estate, A Block, 1st Floor, Dr
Annie Besant Rd, Worli, Mumbai,
Maharashtra 400018

TITLE

JOSH (KITCHEN
EQUIPMENT)

PROJECT

MUMBAI , T-2

JOSH

EQUIPMENT SCHEDULE @

DATE

31-Jul-24

MUMBAI - T2

SR.No.	Eq.No.	DESCRIPTION	MODEL NO	DIMENSIONS(L x W x HT)	QTY	ELECTRIC SUPPLY	Per Kw	TOTAL KW	AMPS	TYPE OF SWITCH
						1HP/3HP				
1	JS-01	POS	IT	STD	2	1PH	1.00	2.0	5 / 15 Amp	Switch Socket
2	JS-02	MARKETING SCREEN	MARKETING	STD	2					
3	JS-03	POS COUNTER WITH STAIR TYPE IMPULSE DISPLAY PROVISION & STORAGE BELOW	CARPENTRY WORK /AS PER ID	1400 x 775 x 850Ht.	1					
4	JS-04	ICE CREAM DISPLAY SHOWCASE-12 FLAVORS	WILLIAMS-SHIRLEY	1229 x 1101 x 1268	1	1PH	1.50	1.5	5 / 15 Amp	Switch Socket
5	JS-05	COUNTER TOP WITH STORAGE BELOW	CARPENTRY WORK /AS PER ID	1075 x 725 x 850Ht.	1					
6	JS-06	2 DOOR U/C REF. SALADETTES & SANDWICH STATION (MAKE LINE UNIT)	BLUESTAR-SC2100GA	900 x 700 x 990	1	1PH	1.50	1.5	5 / 15 Amp	Switch Socket
7	JS-07	HARD TOP CHEST FREEZER - CAP 100 LTR	BLUESTAR-CF3-130NEYW	575 x 570 x 829Ht.	1	1PH	1.00	1.0	5 / 15 Amp	Switch Socket
8	JS-08	3 DOOR U/C REF. SALADETTES & SANDWICH STATION (MAKE LINE UNIT) WITH MARBLE PIECE ON TOP (450 x 450)	BLUESTAR-SC3100GA	1365 x 700 x 990	1	1PH	1.50	1.5	5 / 15 Amp	Switch Socket
9	JS-09	SS CIVIL COUNTER FITTED SINK	FABRICATED	600 x 600 x 150	1					
10	JS-09a	GARBAGE BINS	SOE	300DIA x 600Ht.	1					
11	JS-10	GREASE TRAP	NUGREEN NGT-08	262 x 355 x 280	1					
12	JS-11	COUNTER WITH SUNK IN SINK	CARPENTRY WORK /AS PER ID	1050 x 725 x 850Ht.	1					
13	JS-12	SINGLE BASKET FRYER 8LTR TOASTMASTER	TOASTMASTER- E-DZ-8L	260 x 410 x 340	1	1PH	3.20	3.2	32	Metal Clad
14	JS-13	WOK INDUCTION (KADAI CAP-3 TO 5 LTR)	FABRICATED	340 x 370 x 150	1	1PH	5.00	5.0	32	Metal Clad
15	JS-14	SS FRONT COOKING UNIT SELF EXHAUST SYSTEM WITH INDUCTION & FRYER	SSS-S-KMU-2E	1410 x 750 x 1350Ht.	2	1PH	3.00	6.0	32	Metal Clad
16	JS-15	SS COLD BAIN MARIE WITH 6 Nos, 1/6 GN PAN CONTAINER 150MM Deep	FABRICATED	462 x 750 x 850Ht.	1	1PH	1.00	1.0	5 / 15 Amp	Switch Socket
17	JS-16	CELFROST ELECTRIC HOT PLATE	CELFROST-CDP850	730 x 510 x 230Ht.	1	1PH	4.40	4.4	32	Metal Clad
18	JS-17	COLD DISPLAY UNIT-3FT	BLUESTAR-KORAL09CSQP	900 x 750 x 1200Ht.	1	1PH	1.00	1.0	5 / 15 Amp	Switch Socket
19	JS-18	COUNTER WITH STORAGE BELOW	CARPENTRY WORK /AS PER ID	1575 x 725 x 850Ht.	1					
20	JS-19	JUICE DISPENSER COMPRESSED WITH ROATER	UGOLINI-ARCTIC COMPACT 12/2	480 x 360 x 570Ht.	1	1PH	2.90	2.9	5 / 15 Amp	Switch Socket
21	JS-20	SS COLD BAIN MARIE WITH 6 Nos, 1/6 GN PAN CONTAINER 150MM Deep	FABRICATED	462 x 750 x 850Ht.	1	1PH	1.00	1.0	5 / 15 Amp	Switch Socket
22	JS-21	2 DOOR U/C REF. SALADETTES & SANDWICH STATION (MAKE LINE UNIT)	BLUESTAR-SC2100GA	900 x 700 x 990	1	1PH	1.50	1.5	5 / 15 Amp	Switch Socket
23	JS-21a	SNEEZ GUARD ON COUNTER TOP	CARPENTRY WORK /AS PER ID	1550 x 300 x 450Ht	1					
24	JS-22	TEA & COFFE MAKER MACHINE-GEMINI	GEMINI	600 x 270 x 470Ht.	1	1PH	2.30	2.3	5 / 15 Amp	Switch Socket
25	JS-23	MILK BOILER INSULATED - 12Ltrs.Cap.	PRADEEP - 111612	320DIA x 580Ht.	1	1PH	1.50	1.5	5 / 15 Amp	Switch Socket
26	JS-24	CIVIL FITTED COUNTER SINK	FABRICATED	400 x 400 x 150	1					
27	JS-25	GREASE TRAP	NUGREEN NGT-08	262 x 355 x 280	1					
28	JS-25a	GARBAGE BINS	SOE	300DIA x 600Ht.	1					
29	JS-26	COUNTER STORAGE BELOW WITH SUNK IN SINK	CARPENTRY WORK /AS PER ID	2085 x 725 x 850Ht.	1					
30	JS-27	SS HOT BAIN MARIE WITH 3 Nos, 1/1 GN PAN 150MM DEEP & REMOVABEL 3Nos, DIVIDER 1U/S, & 2 O/S	FABRICATED	1600 x 700 x 850+300 + 260	1	1PH	3.00	3.0	32	Metal Clad
31	JS-28	SS WORK TABLE WITH 2 U/S	FABRICATED	925 x 700 x 850Ht	1					
32	JS-29	TABLE TOP RICE COOKER	20 Ltrs.-5Kg. PANASONIC -SR972	STD	1	1PH	2.00	2.0	5 / 15 Amp	Switch Socket

33	JS-30	SS TABLE TOP ELECTRIC IDLI STEAMER NON STICK TRAY	FABRICATED	380 x 345 x 690Ht.	1	1PH	3.00	3.0	32	Metal Clad
34	JS-31	EXHAUST CHIMNEY WITH CARBON FILTER & SHOULD BE DUCT LESS WALL MOUNTED FLAT	MAGILO-SLATE	600 x 550 x 400Ht.	1	1PH	1.00	1.0	5 / 15 Amp	Switch Socket
35	JS-32	2 DOOR VERTICAL FREEZER WITH LOCKABLE CASTOR WHEELS (2 Nos.WITH BREAK INFRONT & 2 Nos. WITHOUT BREAK) & HEATING ELEMENT FOR DRAIN	BLUE STAR-RF2D550N	700 x 765 x 1997	1	1PH	1.00	1.0	5 / 15 Amp	Switch Socket
Total Kw								47.3		
SOE										
1	SO-01	INSECT KILLERS	SOE		2	1PH	0.50	1.00	5 / 15 Amp	Switch Socket
2	SO-02	FIRE EXTINGUISHER ABC-4KG	SOE		1					
3	SO-03	FIRE EXTINGUISHER CO/2-4.5KG	SOE		1					
4	SO-04	FIRE EXTINGUISHER KTYPE - 6KG	SOE		1					
5	SO-05	FIRE BLANKET - 6' X 4'	SOE		1					
Total Kw-SOE								1.0		
Total Kw								48.3		



INHOUSE DESIGN

JOSH LAYOUT @ T2-MUMBAI

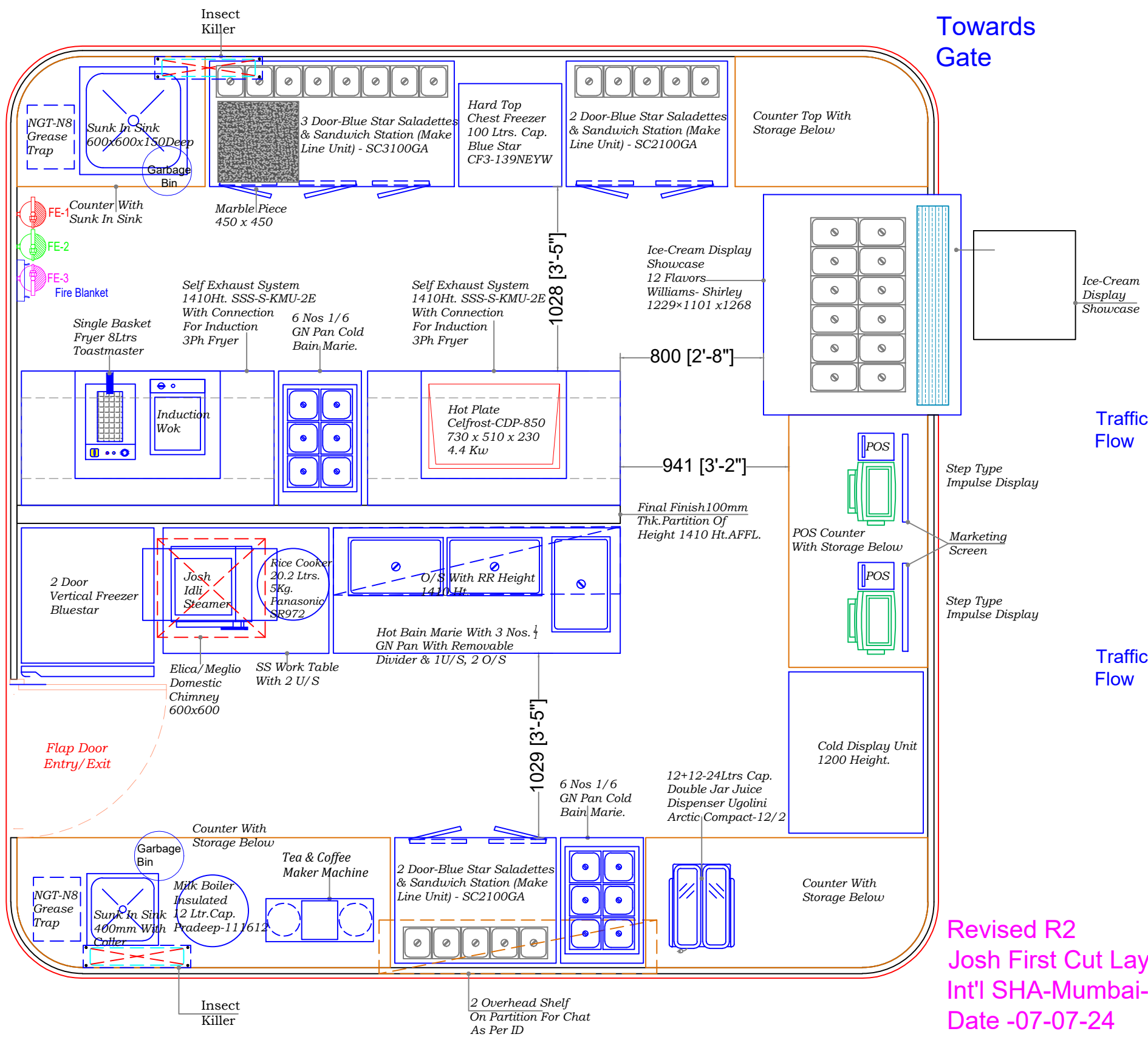

Revised R2
Josh First Cut Layout
Int'l SHA-Mumbai-T2
Date -07-07-24

SYMBOL	DESCRIPTION	QTY.
FE-1	Fire Extinguisher ABC-4Kg	01 No.
FE-2	Fire Extinguisher CO ₂ -4.5Kg	01 No.
FE-3	Fire Extinguisher KType - 6Kg	01 No.
Blanket	Fire Blanket - 6' X 4'	01 No.

PROJECT	LOCATION	DRAWN BY	START DATE	CHK BY	DATE	REVISION No.	FINAL APPROVED	DRAWING	DRAWING NAME	SHEET NUMBER
JOSH LAYOUT	T2-MUMBAI	SAEED	07-07-24			-			EQUIP NAMING LAYOUT	01 OF 06
		DWG.No.		SCALE		REVISION DATE :	DATE			
		----		NTS.		-				

TRAVEL FOOD SERVICES

FABRICATION DETAIL

PLAIN TOP

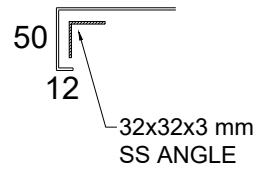

PLAIN TOP WITH SPLASH DETAILS

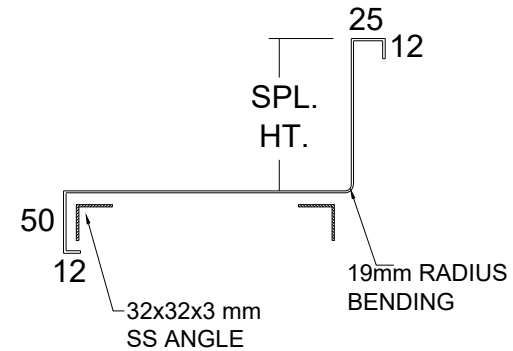

SUNK IN TOP

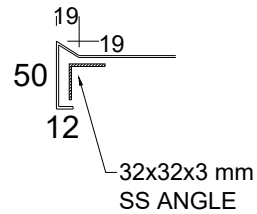

SUNK-IN TOP WITH SPLASH DETAILS

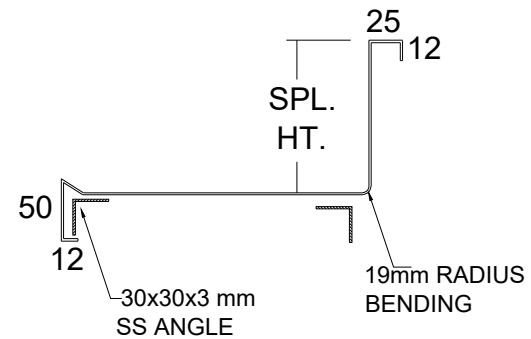

TITLE :	JOSH	REV. NO :	---	DESIGN BY	Sign	 Travel Food Services
		DATE :	31-07-2024	DWN. BY : FAHEEM		
PROJECT :	MUMBAI , T-2	SCALE :	N.T.S.	CHKD BY: SAEED K.		
				APRVD BY:		

TRAVEL FOOD SERVICES

Eq.No :- JS-04

**ICE CREAM DISPLAY SHOWCASE-12
FLAVORS (WILLIAMS-SHIRLEY)**

Over All Size:- 1229 x 1101 x 1268

Qty:- 1 No.

DRAWING Dimensons Are In MM

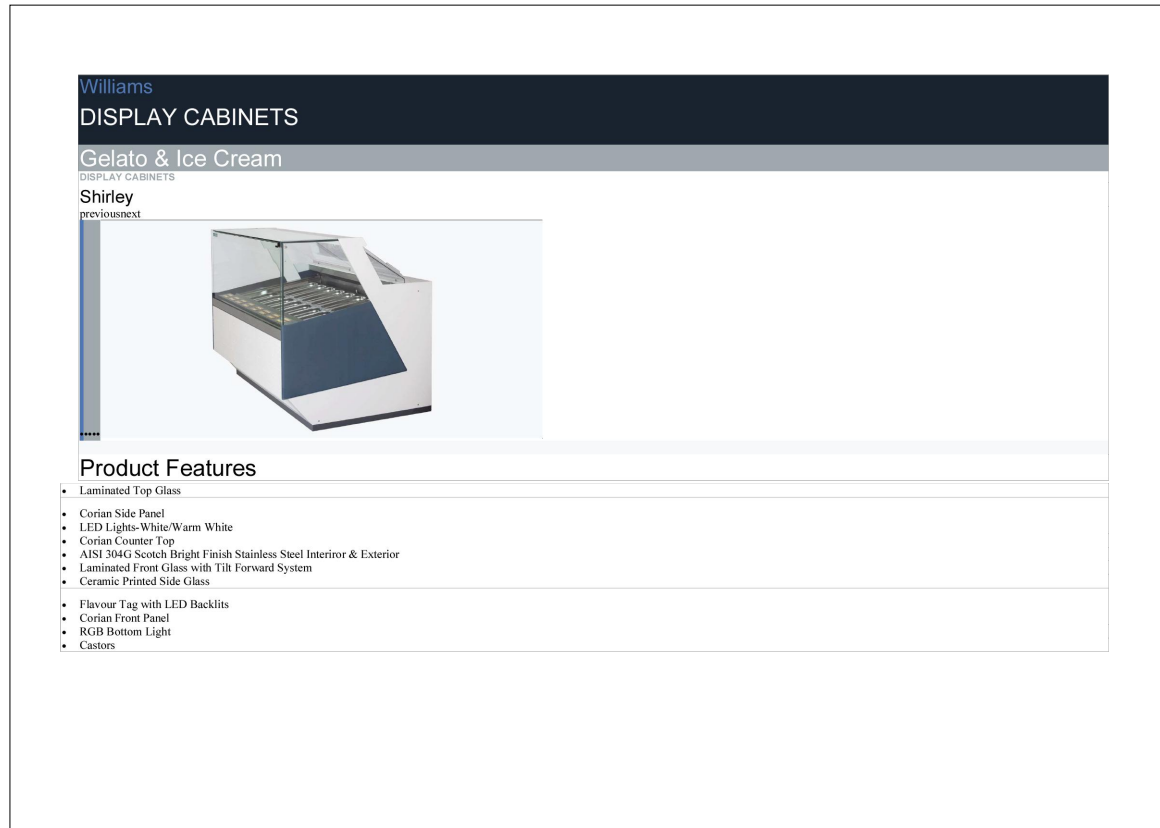

TITLE :	JOSH	REV. NO :		DESIGN BY	Sign	 Travel Food Services
		DATE :	31-07-2024	DWN. BY : FAHEEM		
PROJECT :	T2 - MUMBAI	SCALE :	N.T.S.	CHKD BY : SAEED		
				APRVD BY:		

TRAVEL FOOD SERVICES

Eq.No :- JS-06

2 DOOR U/C REF. SALADETTES & SANDWICH STATION
(MAKE LINE UNIT)- BLUESTAR-SC2100GA

Over All Size:- 900 x 700 x 990

Qty:- 1 No.

DRAWING Dimensons Are In MM



Technical Specifications		
Saladettes and Sandwich Stations		
Description	SC2100GA	SC3100GA
Capacity (Ltr.)	240	400
No. of Doors (Nos.)	2	3
Type of Doors (In/Out)	IS-200/200	IS-200/200
Temperature Range (C)	2°+ ± 8°C	2°+ ± 8°C
Shelves Qty (Nos.)	2	3
Gas Pan	GN2/1	GN2/1
Top/Up Fan Size	185	185
Refrigerant Gas (Type/Charge)	R290/35g	R290/90g
Voltage supply & Frequency (V/Hz)	220-240V/50Hz	220-240V/50Hz
Max Input Power	143W	152W
Current (Amps)	1.3A	1.5A
Defrost	Automatic	Automatic
Thermocast	Digital	Digital
External Dimension (W x D x H) mm	900 x 700 x 990	1365 x 700 x 990
Net Weight (kg)	72	110
Gross Weight (kg)	80	120



TITLE :	JOSH	REV. NO :		DESIGN BY	Sign	 Travel Food Services
		DATE :	31-07-2024	DWN. BY : FAHEEM		
PROJECT :	T2 - MUMBAI	SCALE :	N.T.S.	CHKD BY: SAEED		
				APRVD BY:		

TRAVEL FOOD SERVICES

Eq.No :- JS-07

HARD TOP CHEST FREEZER - CAP 100 LTR- BLUESTAR-CF3-130NEYW

Over All Size:- 575 x 570 x 829

Qty:- 1 No.

DRAWING Dimensions Are In MM

HARD TOP DEEP FREEZER



Our compact hard-top deep freezer is ideal for residences and commercial spaces. They are certified with Star labelling, ensuring energy savings. Additionally, they come with unique features like Super Tropicalised, ensuring they perform even when it's 47°C outside and QuadraCool Technology, which cools uniformly from all sides. They are manufactured in our state-of-the-art facility in India, making them truly Indian at heart.

FEATURES

- COMPACT MACHINE**
Ideal for small storage.
- WIDE RANGE - ELEGANT CONTROL PANEL**
Smart eye and Square design with LED light.
- PLASTIC BASKETS**
Long-lasting, corrosion-free, food-grade.
- SUPER TROPICALISED**
Designed to work even in 47°C ambient summer conditions.
- ROBUST CONSTRUCTION FOR LONG LIFE**
- QUADRA-COOL TECHNOLOGY**
Ensures even and optimum cooling from four sides.

TECHNICAL SPECIFICATION - HARD TOP DEEP FREEZER

Specification	Unit	DT2-130NEYW	DT3-130NEYW	DT4-130NEYW	DT4-220NEYW
Star Rating		2 Star	3 Star	4 Star	4 Star
Gross Capacity	L	71	108	161	216
Temperature Range		+8°C to -26°C	+8°C to -26°C	+8°C to -26°C	+8°C to -26°C
Refrigerant		R600a	R600a	R600a	R600a
No. of Lids		1	1	1	1
Inner Cabinet		Embossed	Embossed	Embossed	Embossed
PIF Thickness	mm	80	80	80	80
Overall Dimensions (WxDxH)	mm	505 X 570 X 809	575 X 570 X 829	765 X 570 X 842	955 X 571 X 842
Overall Dimensions (WxDxH)	inch	20x22x33	23x22x33	30x22x33	38x22x33
Net Weight	kg	25	28	31	35
Baskets - Plastic		1	1	1	1

** Product images are for representation purpose only
***Due to continuous product development cycles, features and technical specifications are subject to change without prior notice.

PG4

GLASS TOP DEEP FREEZER



Our compact glass top deep freezer is the ultimate solution for commercial use, offering optimal storage space and Low E-Toughened glass that seamlessly displays products stored inside. Available in multiple-coloured frames and Star rating which ensures energy-saving capabilities. Manufactured in our state-of-the-art facility, this product is proudly Made in India.

FEATURES

- OPTIMIZED STORAGE SPACE**
Chest placement of the top panel in the industry (finger depth) allows for maximum display of stored items. Increases storage capacity to store more goods.
- MULTI-COLOUR FRAME OPTIONS**
Allows for customisation to enhance brand display and awareness.
- SUPER TROPICALISED**
Designed to work even in 47°C ambient summer conditions.
- MAXIMUM FRONTAL BRANDING AREA**
Temperature controller on side grill ensures 100% space for branding on the front.
- LOW E-TOUGHENED GLASS**
Reflects glare for high performance and better visibility.
- PLASTIC BASKETS**
Long-lasting, corrosion-free, food-grade.

TECHNICAL SPECIFICATION - GLASS TOP DEEP FREEZER

Model	Unit	DT4-130NP	DT4-180NP	DT4-220NP
Star Rating		5 Star	5 Star	5 Star
Gross Capacity	L	108	161	216
Temperature Range		-13.5°C to -26°C	-13.5°C to -26°C	-13.5°C to -26°C
Refrigerant		R600a	R600a	R600a
No. of Lids		2	2	2
Inner Cabinet		Embossed	Embossed	Embossed
PIF Thickness	mm	80	80	80
Overall Dimensions (WxDxH)	mm	577 X 527 X 810	767 X 527 X 810	957 X 527 X 810
Overall Dimensions (WxDxH)	inch	23 X 21 X 32	30 X 21 X 32	38 X 21 X 32
Net Weight	kg	29	32	37
Baskets - Plastic		1	1	2

** Product images are for representation purpose only
***Due to continuous product development cycles, features and technical specifications are subject to change without prior notice.

PG5

TITLE :

JOSH

REV. NO :

DESIGN BY

Sign

DATE :

31-07-2024

DWN. BY : FAHEEM

PROJECT :

T2 - MUMBAI

SCALE :

N.T.S.

CHKD BY: SAEED

APRVD BY:



Travel Food Services

TRAVEL FOOD SERVICES

Eq.No :- JS-08

3 DOOR U/C REF. SALADETTES & SANDWICH STATION (MAKE LINE UNIT)
WITH MARBLE PIECE ON TOP (450 x 450) - BLUESTAR-SC3100GA

Over All Size:- 1365 x 700 x 990

Qty:- 1 No.

DRAWING Dimensons Are In MM



Technical Specifications

Saladettes and Sandwich Stations		
Description	SC3100GA	SC3100GA
Capacity (Ltr)	280	400
Capacity (Bread)	2	3
Qty of Doors (Panel)	15-201/201	15-201/201
Type of Doors (Material)	Z ⁺ - 4 #PC	Z ⁺ - 4 #PC
Temperature Range (OC)	2	3
Shelves Qty (No.)	2	3
Grill Fan	GR2/1	GR2/1
Topping Fan Start	YES	YES
Refrigerant Gas (Type/Charge)	R290/55g	R290/50g
Voltage supply & Frequency (V/Hz)	220-240V/50Hz	220-240V/50Hz
Max Input Power	145W	152W
Current Amps	1.5A	1.5A
Defrost	Automatic	Automatic
Thermostat	Digital	Digital
External Dimension (W x D x H)mm	900 x 700 x 990	1365 x 700 x 990
Net Weight (kg)	72	110
Gross Weight (kg)	83	130



TITLE :	JOSH	REV. NO :		DESIGN BY	Sign	 Travel Food Services
		DATE :	31-07-2024	DWN. BY : FAHEEM		
		PROJECT :	T2 - MUMBAI	SCALE :	N.T.S.	
				APRVD BY:		

TRAVEL FOOD SERVICES

Eq.No :- JS-09

SS CIVIL COUNTER
FITTED SINK

Over All Size:- 600 x 600 x 150mm DEEP

Qty:- 1 No.

DRAWING Dimensons Are In MM

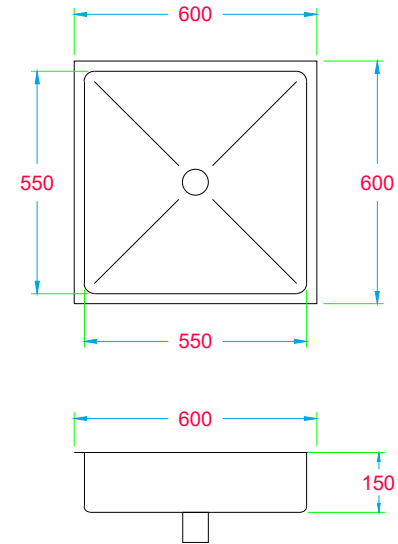
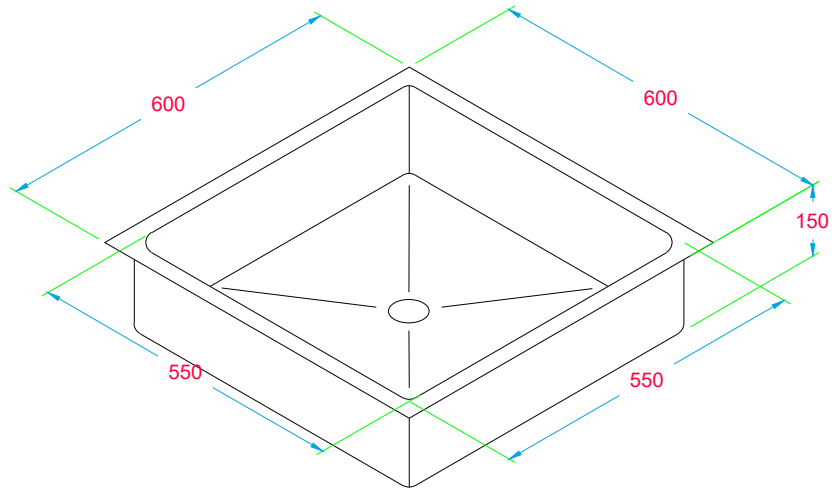

TITLE :	JOSH	REV. NO :		DESIGN BY	Sign	 Travel Food Services
		DATE :	31-07-2024	DWN. BY : FAHEEM		
PROJECT :	T2 - MUMBAI	SCALE :	N.T.S.	CHKD BY: SAEED		
				APRVD BY:		

TRAVEL FOOD SERVICES

Eq.No :- JS-10

GREASE TRAP
(NUGREEN NGT-08)

Over All Size:- 262 x 355 x 280

Qty:- 1 No.

DRAWING Dimensons Are In MM

NUGREEN
Building Technologies Pvt. Ltd.

SS Grease Trap

Are you one of these facilities!

- Airports
- Restaurants in High Rise Buildings
- Hospitals
- Hotels
- Cafeteria
- Grocery Store Kitchens and Delicatessens
- Casinos
- Food Processing Plants
- School Cafeterias
- Strip Shopping Centres
- Concession Stands
- Fast Food Restaurants
- Convenience Stores
- Convention Centers
- Correctional Facilities
- Full Service Restaurants

Have you seen pipes that look like this?

NUGREEN Building Technologies Pvt. Ltd.

Nugreen Grease separator " NGT 8/14/20/30/40/50/70/100 "									
Grease Trap SS 304	Inlet/Outlet (mm)	Holding Capacity (Litre)	Flow (Lit/min)	Bottom to Centre of Inlet (A) (mm)	Bottom to Centre of outlet (B) (mm)	Width (mm)	Length (mm)	Height (mm)	Grease capacity (kg)
NGT 8	50	15.9	18	177	177	262	355	280	3
NGT 14	50	25.5	28	203	193	337	404	303	7
NGT 20	60	34.3	38	203	193	362	503	303	9
NGT 30	75	47.5	57	256	246	400	512	343	13
NGT 40	87.5	57.5	75.5	287	277	400	562	375	18
NGT 50	87.5	72	95	300	290	437	612	412	23
NGT 70	87.5	104	132	353	343	450	712	481	32
NGT 100	112	156	189	406	396	556	762	537	45

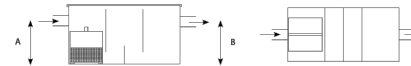

Description:

- For free standing Installation in frost free areas, with integrated sludge trap, SS quick release odour-tight covers.
- Inlet and outlet varies from Ø 50mm to Ø 112mm.
- Sludge trap content: ----- Litre.
- Grease trap content: ----- Litre.

Manufacturer:

Nugreen Building Technologies Pvt Ltd, New Delhi

Application:

- Especially suitable in areas in which limited amounts of fat and sludge occur, and above all wherever vegetable oil is used.
- Grease separator system should be emptied on a daily basis.

Nugreen-advantages:

- System made form SS 304 2 mm thick for corrosion free compact structure.
- Sturdy and long lasting structure.
- Fast removal of cover for easy maintenance.
- Inlet meets all on-site requirements.
- Innovative & easy to remove SS304 sieve basket for sludge collection.

NUGREEN

Nugreen Building Technologies (P) Ltd.
C-6, Basement, Unit D, Rajouri Garden
New Delhi - 110027
Tel : +91 11 45715964
Email: info@nugreen.co.in
Website: www.nugreen.co.in



TITLE :	JOSH	REV. NO :		DESIGN BY	Sign
		DATE :	31-07-2024	DWN. BY : FAHEEM	
		SCALE :	N.T.S.	CHKD BY: SAEED	
PROJECT :	T2 - MUMBAI			APRVD BY:	



Travel Food Services

TRAVEL FOOD SERVICES

Eq.No :- JS-12

**SINGLE BASKET FRYER 8LTR
TOASTMASTER (TOASTMASTER- E-DZ-8L)**

Over All Size:- 260 x 410 x 340

Qty:- 1 No.

DRAWING Dimensons Are In MM



These professional fryers are particularly suited for fast food restaurants. Suitable for frying chips, fish, onion rings in quick succession using minimal quantities oil.

- High efficiency stainless steel heating element
- Min-Maximum oil level
- Cover for tank
- 190°C temperature limiter for double safety

Models	Tank Capacity	Power	Dimensions (W x D x H) mm	Volts
E-DZ-8L	8 Ltrs	3.25 KW	260 x 410 x 340	220 V
E-DZ-4L	4 Ltrs	2 KW	220 x 390 x 370	220 V
E-DZ-6L-2	2x6 Ltrs	2.6 KW	2400 x 300 x 140	220 V
E-DZ-8L-TP	8 Ltrs	2.5 KW	260 x 210 x 370	220 V

TITLE :	JOSH	REV. NO :		DESIGN BY	Sign	 Travel Food Services
		DATE :	31-07-2024	DWN. BY : FAHEEM		
PROJECT :	T2 - MUMBAI	SCALE :	N.T.S.	CHKD BY: SAEED		
				APRVD BY:		

TRAVEL FOOD SERVICES

Eq.No :- JS-13

SS TABLE TOP WOK INDUCTION
(KADAI CAP-3 TO 5 LTR)

Over All Size:- 340 x 370 x 150Ht.

Qty:- 1 No.

DRAWING Dimensons Are In MM

ELECTRIC LOAD : 5KW
SINGLE PHASE
KADAI CAP : 3 TO 5 LTR

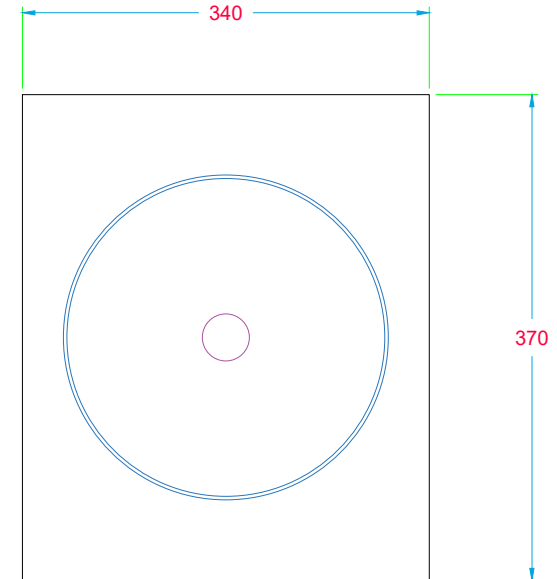
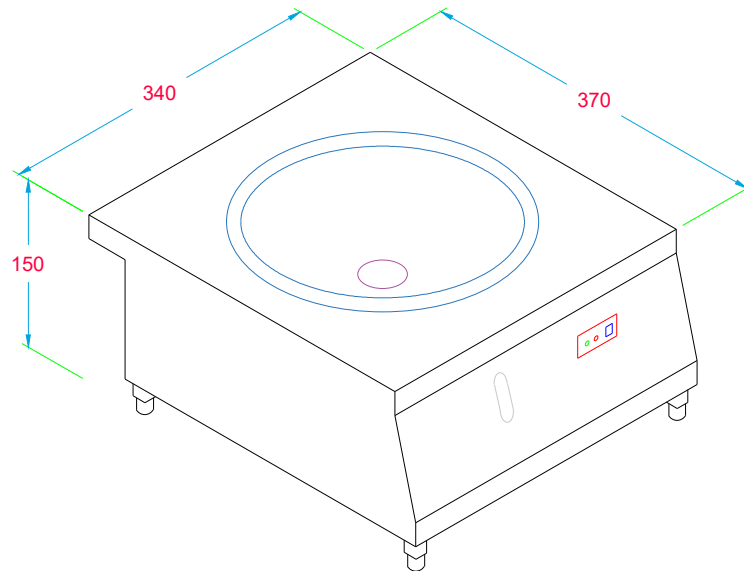

TITLE :	JOSH	REV. NO :		DESIGN BY	Sign	 Travel Food Services
		DATE :	31-07-2024	DWN. BY : FAHEEM		
PROJECT :	T2 - MUMBAI	SCALE :	N.T.S.	CHKD BY: SAEED		
				APRVD BY:		

TRAVEL FOOD SERVICES

Eq.No :- JS-14

SS FRONT COOKING UNIT SELF EXHAUST SYSTEM WITH INDUCTION & FRYER (SSS-S-KMU-2E)

Over All Size:- 1410 x 750 x 1350Ht.

Qty:- 2 Nos.

DRAWING Dimensons Are In MM



SSS
KITCHEN EQUIPMENT

NOMAD FRONT COOKING UNIT
with extraction system MODEL S-KMU-2



VIANEN Powered by Dutch technology



ELECTRA



APPLICATION

The mobile front cooking unit for professional use provides the ideal solution when cooking in front of audiences in places such as show cooking at exhibitions and catering for parties. Deep frying, grilling, steaming are just a few of the endless applications for the S-KMU-2 unit.

An integrated extraction system is built into the system, reducing the odours and capturing the grease and fumes.

FECON FILTER

The flame retardant Fecon filters provide safety as the flash flames do not pass the filters.

The Model S-KMU-2 provides place for maximum 2 table top cooking units. The design of the S-KMU-2 allows for good visibility from both sides of the unit for presentation purposes. The air stream supply is introduced from the rear of the unit so that the heat is directed to the lter bank.



OPTIONS

Collapsible shelves for additional storage/workspace.
Front cover plate.

TECHNICAL DETAILS MODEL S-KMU-2

2 nos. Exhaust fan 230V – 50Hz	1 nos. Plug with cable 400V – 50Hz
1 nos. Supply fan 230V – 50Hz	2 nos. Removable inspection panels
4 nos. Fecon filters dimensions 400 x 200 x 36mm	4 nos. Castors – 2 with brakes
6 nos. Carbon filters	1 nos. Switch board 400V x 230V
1 nos. Pre-filter	1 nos. LED strip lighting 5 Watt
2 nos. Electrical connections 230V	
2 nos. Electrical connections 400V	



info@sss-india.in
www.sss-india.in
Teli +91 8028454582
Southern Stainless Steel Fabrication India Pvt Ltd
Unit #G-8 Shreno Ltd. Campus
Near Railway Station Whitefield
Bangalore - 560066 India



TITLE :	JOSH	REV. NO :		DESIGN BY	Sign
		DATE :	31-07-2024	DWN. BY : FAHEEM	
PROJECT :	T2 - MUMBAI	SCALE :	N.T.S.	CHKD BY: SAEED	
				APRVD BY:	



TRAVEL FOOD SERVICES

Eq.No :- JS-15

**SS COLD BAIN MARIE WITH 6Nos, CONTAINER
1/6 GN PAN & LID 150MM DEEP**

Over All Size:- 462 x 750 x 850Ht.

Qty:- 1 No.

DRAWING Dimensons Are In MM

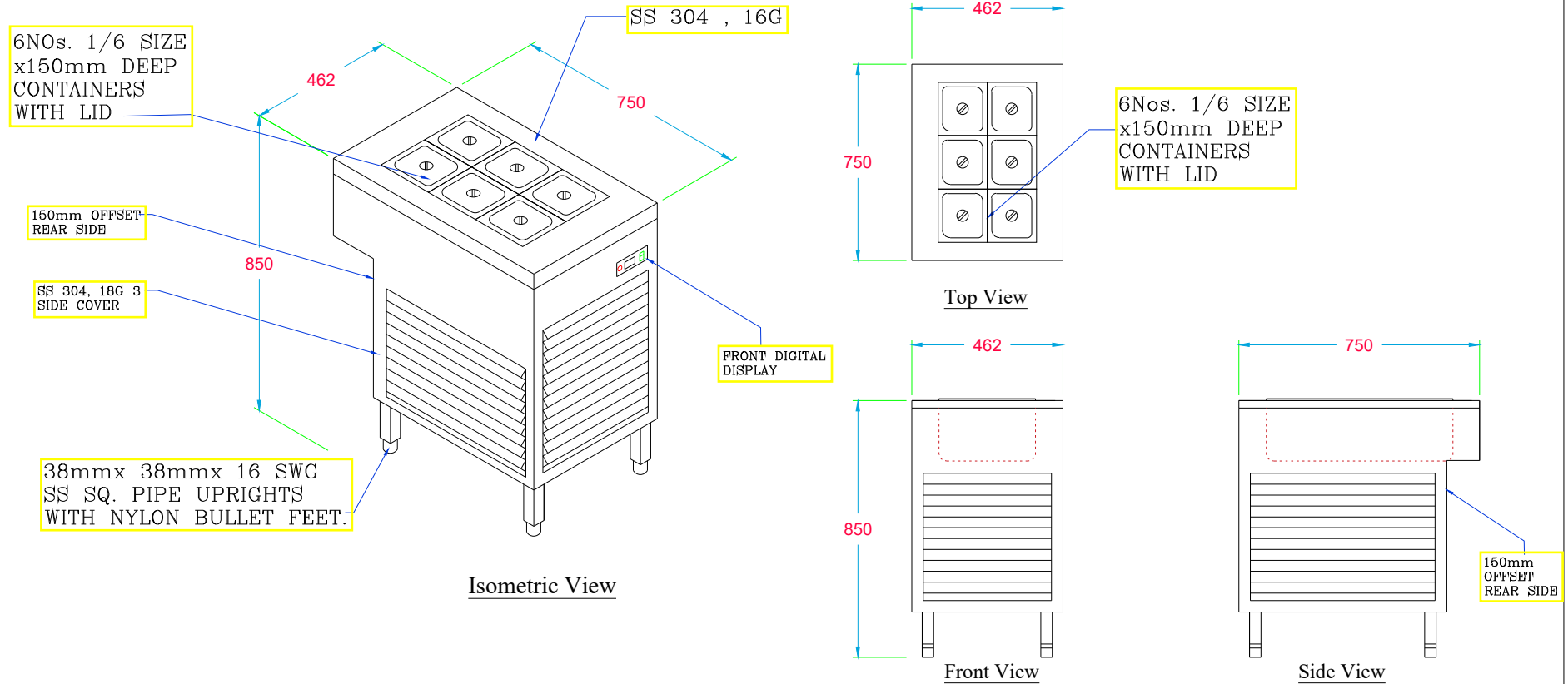

TITLE :	JOSH	REV. NO :		DESIGN BY	Sign	 Travel Food Services
		DATE :	31-07-2024	DWN. BY : FAHEEM		
PROJECT :	T2 - MUMBAI	SCALE :	N.T.S.	CHKD BY: SAEED		
				APRVD BY:		

TRAVEL FOOD SERVICES

Eq.No :- JS-16

CELFRUST ELECTRIC HOT PLATE
(CELFRUST-CDP850)

Over All Size:- 730 x 510 x 230Ht.

Qty:- 1 No.

DRAWING Dimensons Are In MM



Size 730mm x 510mm x 230mm
Type Electric
Color Silver
Model Name/Number -CDP-850
Height 230 mm
Power 4.4 KW
Width 730 mm

TITLE :	JOSH	REV. NO :		DESIGN BY	Sign	
		DATE :	31-07-2024	DWN. BY : FAHEEM		
PROJECT :	T2 - MUMBAI	SCALE :	N.T.S.	CHKD BY: SAEED		
				APRVD BY:		

TRAVEL FOOD SERVICES

Eq.No :- JS-19

JUICE DISPENSER COMPRESSED WITH ROATER
(UGOLINI-ARCTIC COMPACT $\frac{12}{2}$)

Over All Size:- 480 x 360 x 570Ht.

Qty:- 1 No.

DRAWING Dimensons Are In MM

ugolini ARCTIC COMPACT

	← cm	↑ cm	↙ cm	Ⓚg	Ⓚg	Ⓚg
Arctic Compact 5/1	18	55	40	13	14	5
Arctic Compact 5/2	25	55	40	17	18	10
Arctic Compact 5/3	37	55	40	22	24	15
Arctic Compact 5/4	50	55	40	27	29	20
Arctic Compact 8/1	18	63	40	14	15	8
Arctic Compact 8/2	25	63	40	17	19	16
Arctic Compact 8/3	37	63	40	22	24	24
Arctic Compact 8/4	50	63	40	29	30	32
Arctic Compact 12/1	18	61	47	17	19	12
Arctic Compact 12/2	36	61	47	23	26	24
Arctic Compact 12/3	54	61	47	37	40	36
Arctic Compact 12/4	72	61	47	50	55	48



Arctic Compact 8 / 3



Pompa sommersa
Submerged pump
Pompe submergée
Tauchpumpe
Bomba sumergible



Rubinetto a gravità
Gravity tap
Robinet à gravité
Schwerkraft-Hahn
Grifo por gravedad



5 / 2



8 / 2



12 / 2

TITLE :	JOSH	REV. NO :		DESIGN BY	Sign	
		DATE :	31-07-2024	DWN. BY : FAHEEM		
PROJECT :	T2 - MUMBAI	SCALE :	N.T.S.	CHKD BY: SAEED		
				APRVD BY:		

TRAVEL FOOD SERVICES

Eq.No :- JS-20

**SS COLD BAIN MARIE WITH 6Nos, CONTAINER
1/6 GN PAN & LID 150MM DEEP**

Over All Size:- 462 x 750 x 850Ht.

Qty:- 1 No.

DRAWING Dimensons Are In MM

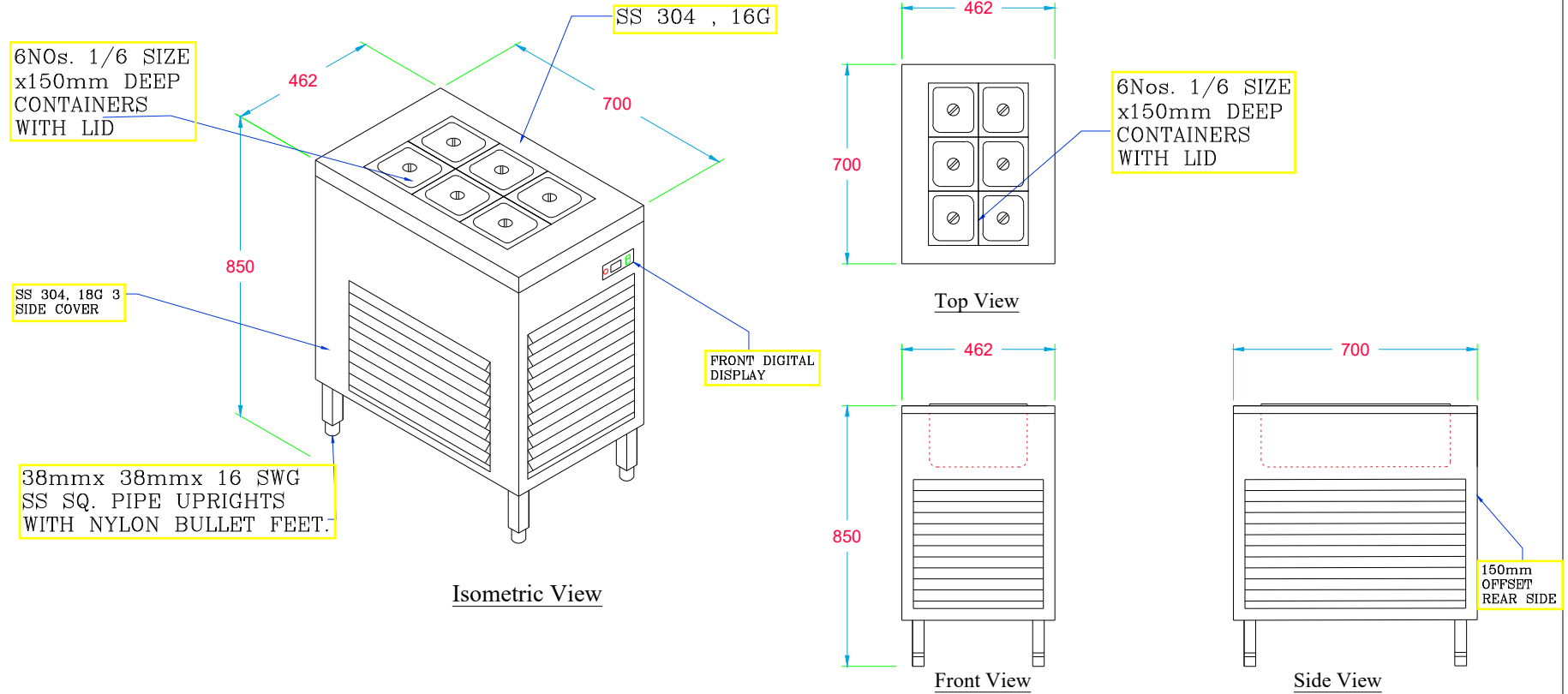

TITLE :	JOSH	REV. NO :		DESIGN BY	Sign	 Travel Food Services
		DATE :	31-07-2024	DWN. BY : FAHEEM		
PROJECT :	T2 - MUMBAI	SCALE :	N.T.S.	CHKD BY: SAEED		
				APRVD BY:		

TRAVEL FOOD SERVICES

Eq.No :- JS-21

**2 DOOR U/C REF. SALADETTES & SANDWICH
STATION (MAKE LINE UNIT) - BLUESTAR-SC2100GA**

Over All Size:- 900 x 700 x 990

Qty:- 1 No.

DRAWING Dimensions Are In MM



Technical Specifications		
Saladettes and Sandwich Stations		
Description	SC2100GA	SC3100GA
Capacity (lits)	260	400
No. of Doors (Nos.)	2	3
Type of Doors (In/Out)	SS-201/201	SS-201/201
Temperature Range °C	2° -- +18°C	2° -- +18°C
Shelves Qty. (Nos.)	2	3
Gas Pan	GN2/1	GN2/1
Trip	YES	YES
Toplights Fan Slot	YES	YES
Refrigerant Gas Type/Charge	R290/51g	R290/60g
Voltage supply & Frequency (V/Hz)	220-240V/50Hz	220-240V/50Hz
Max Input Power	145W	155W
Current Amps	1.1A	1.5A
Defrost	Automatic	Automatic
Thermostat	Digital	Digital
External Dimension (W x D x H) mm	900 x 700 x 990	1365 x 700 x 990
Net Weight (kg)	72	110
Gross Weight (kg)	82	120



TITLE :

JOSH

REV. NO :

DESIGN BY

Sign

DATE : 31-07-2024

DWN. BY : FAHEEM

PROJECT :

T2 - MUMBAI

SCALE : N.T.S.

CHKD BY: SAEED

APRVD BY:



Travel Food Services

TRAVEL FOOD SERVICES

Eq.No :- JS-22

**TEA & COFFE MAKER
MACHINE**

Over All Size:- 600 x 240 x 470Ht.

Qty:- 1 No.

DRAWING Dimensons Are In MM



TEA AND COFFEE MAKER MACHINE

★★★★★ (9 customer reviews)

Availability: In Stock

Brand: Gemini

Product Code: Tea Coffee Maker

HIGHLIGHTS

Type	Tea Coffee Maker
Beverage Options	Six
Brand	Gemini
Dimension	600 mm * 240 mm * 470 mm
Capacity	110 - 130 Cups
Current	4 Amps
Power Consumption	230 V A/c
Storage Tank Capacity	2 Litres
Decoction Output	20 Minutes

TITLE :	JOSH	REV. NO :		DESIGN BY	Sign	 Travel Food Services
		DATE :	31-07-2024	DWN. BY : FAHEEM		
PROJECT :	T2 - MUMBAI	SCALE :	N.T.S.	CHKD BY: SAEED		
				APRVD BY:		

TRAVEL FOOD SERVICES

Eq.No :- JS-23

MILK BOILER INSULATED -
12Ltrs.Cap. (PRADEEP - 111612)

Over All Size:- 320DIA x 580Ht.

Qty:- 2 Nos.

DRAWING Dimensons Are In MM



Home / Milk / Indirect Heating & Milk Boiler Machines

Milk

Indirect Heating & milk boiler machines

Dispensing Option: Hot Milk, Hot Water

Fill Options: Manual Functions

Power: 220-240v Ac,15hz, 15A

No. of cups per minute: 7-8 cups (100ml)

Pradeep Insulated milk boiler machines

Features :

Model No	LxWxH	Capacity
111600	470×280	5 lit
111612	580×320	12lit
111620	550×380	20lit
111630	670×390	30lit

TITLE :	JOSH	REV. NO :		DESIGN BY	Sign	
		DATE :	31-07-2024	DWN. BY : FAHEEM		
PROJECT :	T2 - MUMBAI	SCALE :	N.T.S.	CHKD BY: SAEED		
				APRVD BY:		

TRAVEL FOOD SERVICES

Eq.No :- JS-24

CIVIL FITTED COUNTER SINK

Over All Size:- 400 x 400 x 150mm Deep

Qty:- 1 No.

DRAWING Dimensons Are In MM

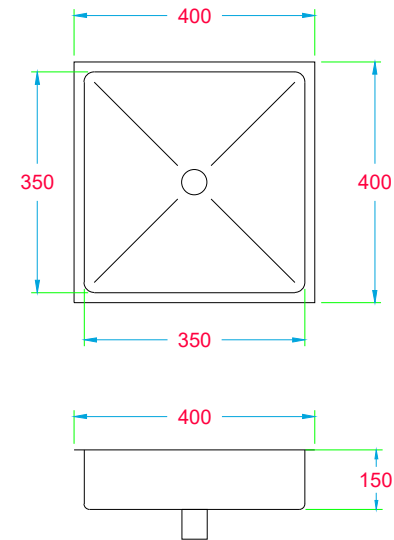
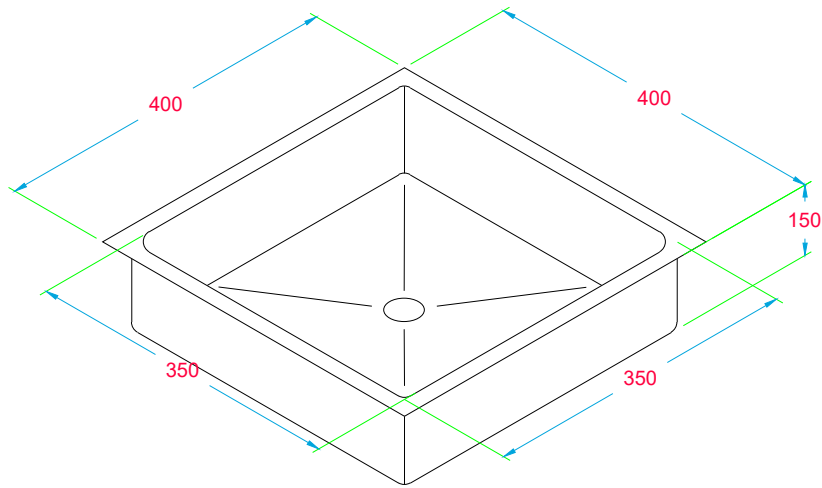

TITLE :	JOSH	REV. NO :		DESIGN BY	Sign	 Travel Food Services
		DATE :	31-07-2024	DWN. BY : FAHEEM		
PROJECT :	T2 - MUMBAI	SCALE :	N.T.S.	CHKD BY: SAEED		
				APRVD BY:		

TRAVEL FOOD SERVICES

Eq.No :- JS-25

GREASE TRAP (NUGREEN NGT-08)

Over All Size:- 262 x 355 x 280

Qty:- 1 No.

DRAWING Dimensons Are In MM

NUGREEN
Building Technologies Pvt. Ltd.

SS Grease Trap

Are you one of these facilities!

- Airports
- Soup Kitchens
- Restaurants in High Rise Buildings
- Hospitals
- Hotels
- Cafeterias
- Grocery Store Kitchens and Delicatessens
- Casinos
- Food Processing Plants
- School Canteens
- Strip Shopping Centers
- Concession Stands
- Fast Food Restaurants
- Convenience Stores
- Correctional Facilities
- Full Service Restaurants
- Convention Centers

Have you seen pipes that look like this?

Nugreen Building Technologies Pvt. Ltd.

Nugreen Grease separator " NGT 8/14/20/30/40/50/70/100 "									
Grease Trap SS 304	Inlet/Outlet (mm)	Holding Capacity (Litre)	Flow (Lit/min)	Bottom to Centre of Inlet (A) (mm)	Bottom to Centre of outlet (B) (mm)	Width (mm)	Length (mm)	Height (mm)	Grease capacity (kg)
NGT 8	50	15.9	18	177	177	262	355	280	3
NGT 14	50	25.5	28	203	193	337	404	303	7
NGT 20	60	34.3	38	203	193	362	503	303	9
NGT 30	75	47.5	57	256	246	400	512	343	13
NGT 40	87.5	57.5	75.5	287	277	400	562	375	18
NGT 50	87.5	72	95	300	290	437	612	412	23
NGT 70	87.5	104	132	353	343	450	712	481	32
NGT 100	112	156	189	406	396	556	762	537	45

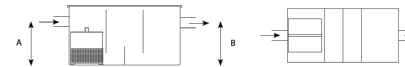

Description:

- For free standing installation in frost free areas, with integrated sludge trap, SS quick release odour-tight covers.
- Inlet and outlet varies from Ø 50mm to Ø 112mm.
- Sludge trap content: ----- Litre.
- Grease trap content: ----- Litre.

Manufacturer:

Nugreen Building Technologies Pvt Ltd, New Delhi

Application:

- Especially suitable in areas in which limited amounts of fat and sludge occur, and above all wherever vegetable oil is used.
- Grease separator system should be emptied on a daily basis.

Nugreen-advantages:

- System made form SS 304 '2 mm' thick for corrosion free compact structure.
- Sturdy and long lasting structure.
- Fast removal of cover for easy maintenance.
- Inlet meets all on-site requirements.
- Innovative & easy to remove SS 304 sieve basket for sludge collection.

NUGREEN

Nugreen Building Technologies (P) Ltd.
C-6, Basement, Unit D, Rajouri Garden
New Delhi - 110027
Tel : +91 11 45715964
Email: info@nugreen.co.in
Website: www.nugreen.co.in



TITLE :	JOSH	REV. NO :		DESIGN BY	Sign	
		DATE :	31-07-2024	DWN. BY : FAHEEM		
		PROJECT :	T2 - MUMBAI	SCALE :	N.T.S.	
				APRVD BY:		

TRAVEL FOOD SERVICES

Eq.No :- JS-27

SS HOT BAIN MARIE WITH 3 Nos, 1/1 GN PAN 150MM DEEP & REMOVABLE 3Nos, DIVIDER 1U/S, & 2 O/S

Over All Size:- 1600 x 700 x 850+300 + 260

Qty:- 1 No.

DRAWING Dimensions Are In MM

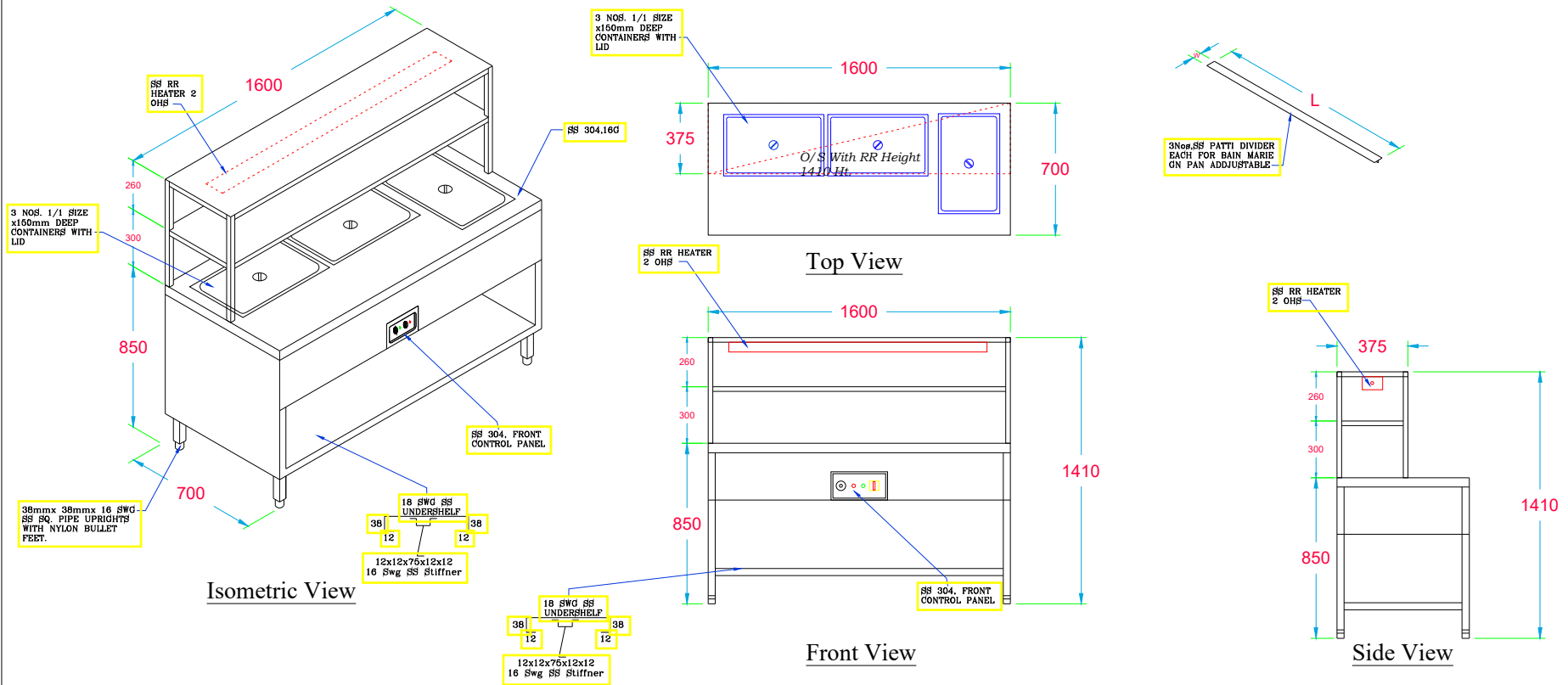

TITLE :	JOSH	REV. NO :		DESIGN BY	Sign	<p>Travel Food Services</p>
		DATE :	31-07-2024	DWN. BY : FAHEEM		
		SCALE :	N.T.S.	CHKD BY: SAEED		
PROJECT :	T2 - MUMBAI			APRVD BY:		

TRAVEL FOOD SERVICES

Eq.No :- JS-28

SS WORK TABLE
WITH 2 U/S

Over All Size:- 925 x 700 x 850Ht

Qty:- 1 No.

DRAWING Dimensons Are In MM

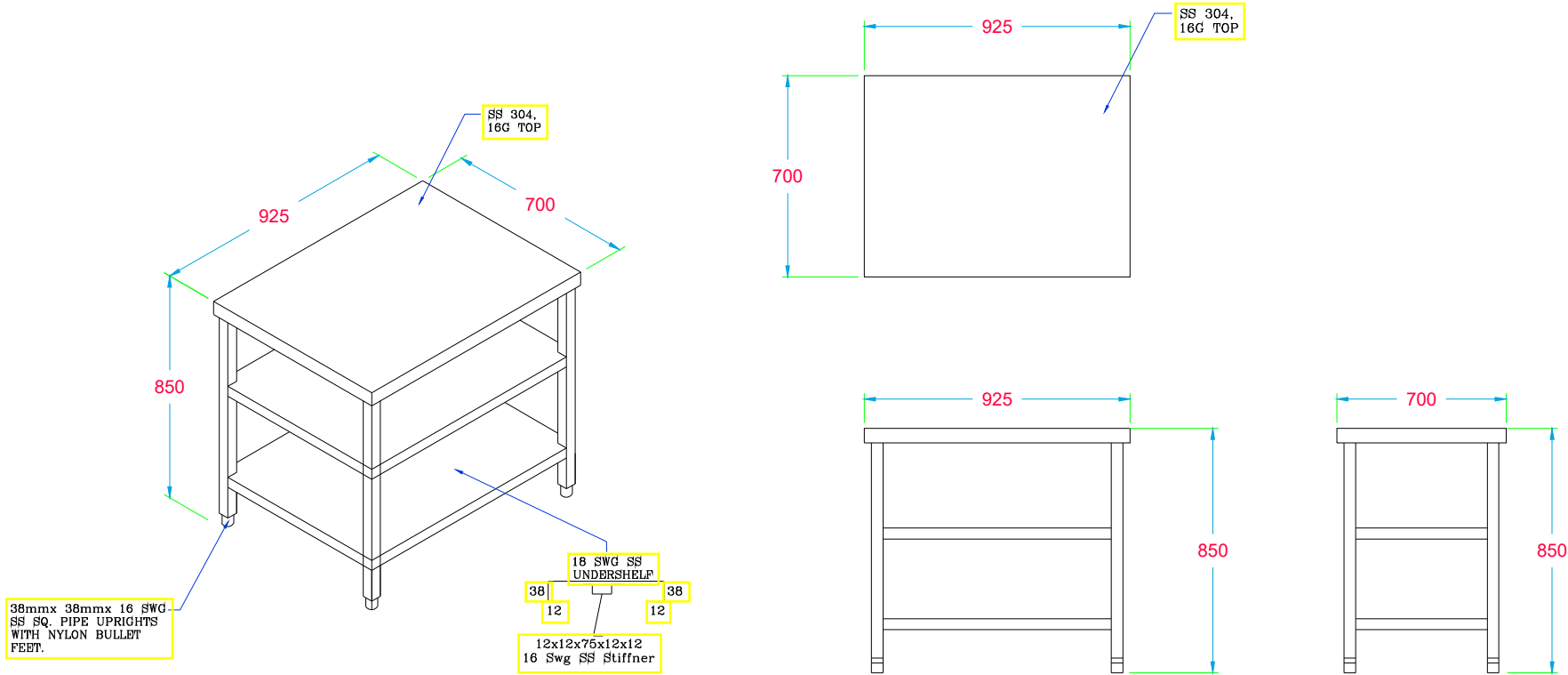

TITLE :	JOSH	REV. NO :		DESIGN BY	Sign	 Travel Food Services
		DATE :	31-07-2024	DWN. BY : FAHEEM		
PROJECT :	T2 - MUMBAI	SCALE :	N.T.S.	CHKD BY: SAEED		
				APRVD BY:		

TRAVEL FOOD SERVICES

Eq.No :- JS-29

TABLE TOP RICE COOKER (20 Ltrs.-5Kg.
PANASONIC -SR972)

Over All Size:- STD

Qty:- 1 No.

DRAWING Dimensons Are In MM



Product Dimensions: 52D
x 52W x 36.5H

Capacity: 20.2

Color: White Material: Cast
Iron, Stainless Steel

Lid Voltage: 220-240V Type of
Product: Rice Cooker Model

No: SR972D Power: 2500 W

TITLE :	JOSH	REV. NO :		DESIGN BY	Sign	 Travel Food Services
		DATE :	31-07-2024	DWN. BY : FAHEEM		
PROJECT :	T2 - MUMBAI	SCALE :	N.T.S.	CHKD BY: SAEED		
				APRVD BY:		

TRAVEL FOOD SERVICES

Eq.No :- JS-30

**SS ELECTRIC TABLE TOP IDLI
STEAMER NON STICK TRAY**

Over All Size:- 380 x 345 x 690Ht.

Qty:- 1 No.

DRAWING Dimensons Are In MM

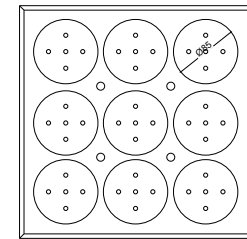
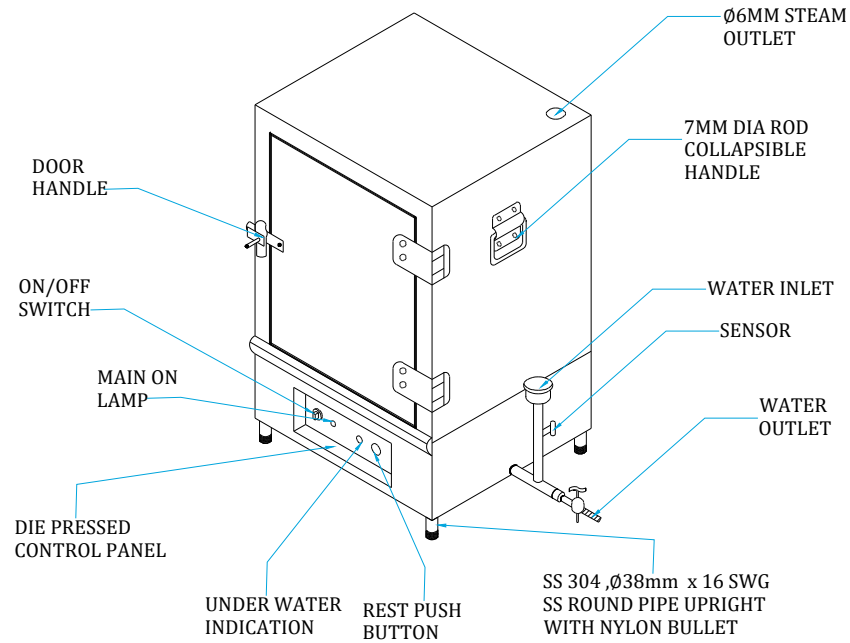

NON STICK IDLI TRAY

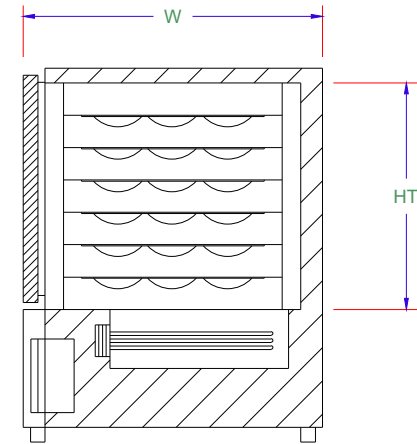

RHS SECTION

WITH 6 Nos 22 SWG SS IDLI NON STICK TRAYS OF APPROX SIZE:- 12 1/8" x 12 1/8" x WIDE AND 3 Nos 18 SWG ALUMINIUM DRIP TRAYS OF APPROX SIZE:- 11 3/4" x 11 3/4" x 3/4" DEEP ELECTRIC LOAD:- 3 kw / 1 phase WITH ELECTRONIC UNDER WATER TRIP & AUDIABLE ALARAM.

TITLE :	JOSH	REV. NO :		DESIGN BY	Sign
		DATE :	31-07-2024	DWN. BY : FAHEEM	
PROJECT :	T2 - MUMBAI	SCALE :	N.T.S.	CHKD BY: SAEED	
				APRVD BY:	



Travel Food Services

TRAVEL FOOD SERVICES

Eq.No :- JS-31

EXHAUST CHIMNEY WITH CARBON FILTER & SHOULD BE DUCT
LESS WALL MOUNTED FLAT (MAGILO-SLATE)

Over All Size:- 600 x 550 x 400Ht.

Qty:- 1 No.

DRAWING Dimensons Are In MM

SLATE

Size : 60/90 cm

Glass Finish

Suction Power upto: 1500 m³/hr.

Baffle Filter

Noise : ≤ 56 dBa

Motion Sensor

Touch Control

Thermal Auto Clean



TITLE :	JOSH	REV. NO :		DESIGN BY	Sign	 Travel Food Services
		DATE :	31-07-2024	DWN. BY : FAHEEM		
PROJECT :	T2 - MUMBAI	SCALE :	N.T.S.	CHKD BY: SAEED		
				APRVD BY:		

TRAVEL FOOD SERVICES

Eq.No :- JS-32

2 DOOR VERTICAL FREEZER WITH LOCKABLE CASTOR WHEELS (2 Nos.WITH BREAK INFRONT & 2 Nos. WITHOUT BREAK) & HEATING ELEMENT FOR DRAIN

Over All Size:- 700 x 765 x 1997 (BLUE STAR-RF2D550N)

Qty:- 1 No.

DRAWING Dimensons Are In MM



Technical Specifications

Description	Reach-in Freezers					
	RF2D700GF	RF4D1450GF	RF2D700GC	RF4D1450GC	RF2D550N*	RF4D1100N*
Capacity (Ltrs)	650	1350	650	1350	600	1200
Temperature Range	-20° ~ -7°C	-20° ~ -7°C	-20° ~ -7°C	-20° ~ -7°C	-18° ~ -10°C	-18° ~ -10°C
No. of Doors	2	4	2	4	2	4
Type of Doors (In./Ext)	22-304/201	22-304/201	22-201/201	22-201/201	SS201/SS201	SS201/SS201
Shelves Qty	3	6	3	6	3	6
Light	Yes	Yes	Yes	Yes	No	No
Refrigerant Gas (Type/Charge)	R290/115g	R290/120g x 2	R290/115g	R290/120g x 2	R290/115g	R290/115g
Voltage & Frequency (V/Hz)	220-240V/50Hz	220-240V/50Hz	220-240V/50Hz	220-240V/50Hz	220-240V/50Hz	220-240V/50Hz
Power (Watts)	522	950	522	950	400	608
Current (Amps)	2.6	4.9	2.6	4.9	4.2	8.9
Defrost	Automatic	Automatic	Automatic	Automatic	Automatic	Automatic
Temperature Display LED	Yes	Yes	Yes	Yes	Yes	Yes
External Dimension (W x D X H) mm	700 x 880 x 2043	1400 x 880 x 2043	700 x 880 x 2043	1400 x 880 x 2043	700 x 765 x 1997	1200 x 760 x 1997
Net Weight (kg)	119	200	119	200	85	90
Gross Weight (kg)	129	214	129	214	120	130

Technical Specifications

Description	Reach-in Chillers					
	RC2D700CP	RC4D1450CP	RC2D700CC	RC4D1450CC	RC2D550N*	RC4D1100N*
Capacity (Ltrs)	650	1350	650	1350	600	1200
Temperature Range	0° ~ +12°C	0° ~ +12°C	0° ~ +12°C	0° ~ +12°C	0° ~ +10	0° ~ +10
No. of Doors	2	4	2	4	2	4
Type of Doors (In./Ext)	22-304/201	22-304/201	22-201/201	22-201/201	SS201/SS201	SS201/SS201
Shelves Qty	3	6	3	6	3	6
Light	Yes	Yes	Yes	Yes	No	No
Refrigerant Gas (Type/Charge)	R290/90g	R290/120g	R290/90g	R290/120g	R290/100g	R290/150g
Voltage & Frequency (V/Hz)	220-240V/50Hz	220-240V/50Hz	220-240V/50Hz	220-240V/50Hz	220-240V/50Hz	220-240V/50Hz
Power (Watts)	250	600	250	600	200	490
Current (Amps)	1.2	3.2	1.2	3.2	1.2	5.5
Defrost	Automatic	Automatic	Automatic	Automatic	Automatic	Automatic
Temperature Display LED	Yes	Yes	Yes	Yes	Yes	Yes
External Dimension (W x D X H) mm	700 x 880 x 2043	1400 x 880 x 2043	700 x 880 x 2043	1400 x 880 x 2043	700 x 765 x 1997	1200 x 760 x 1997
Net Weight (kg)	112	190	112	190	85	90
Gross Weight (kg)	122	204	122	204	120	130



TITLE :

JOSH

PROJECT :

T2 - MUMBAI

REV. NO :

DATE :

SCALE :

31-07-2024

N.T.S.

DESIGN BY

DWN. BY : FAHEEM

CHKD BY: SAEED

APRVD BY:

Sign



Travel Food Services