

INKBIRD INK-IFT02 INFRARED THERMOMETER

USER MANUAL

SPECIFICATION

Product Name	Infrared Thermometer
Temperature Range	-50°C ~ 550°C (-58°F ~ 1022°F)
Measurement Accuracy	≥ 100°C, ±2% / ≤ 100°C, ±2°C
Object Distance Ratio	12:1
Response Time	500Ms (0.5s)
Emissivity	0.95
Temperature Unit	°C/°F (factory default)
Auto Off	15 seconds
Working Temperature	0°C ~ 45°C (-4°F ~ 113°F)
Storing Temperature	-10°C ~ 45°C (32°F ~ 113°F)
Charging Port	USB Type-C
Power Supply	250 mAh Lithium Battery (built-in)
Product Warranty	1 Year

OVERVIEW

INKBIRD INK-IFT02 adopts non-contact infrared sensing technology and is capable of detecting the temperatures of objects securely, accurately, rapidly, and reliably. You can use it in temperature measurement of dangerous and inaccessible objects in high-heat environments such as mechanical engineering, chemical engineering, light engineering, metallurgy, ceramics, food processing, electricity, and heat treatment.

WORKING PRINCIPLE

Any object of which temperature is higher than absolute zero can radiate infrared energy, which will transmit everywhere all-around at the speed of light. Thus, the optical lens of the infrared thermometer will collect all infrared energy and gather it on the sensor to produce a low-voltage output that is proportionate to the object's temperature. The voltage output will be processed and transformed to display as a temperature value.

OPERATION INSTRUCTION

The infrared thermometer is constructed in several parts. Please refer to the introduction below when using it (as shown in figure 1-1).

- **Starting Up**

Press the POWER/SCAN button to turn on the device. The thermometer will start self-checking and automatically measure and display the temperature value.

- **Liquid Crystal Display**

After turning on the device, you can see all functional icons on the screen (as shown in

figure 1-2).

- **Measurement**

Point the laser to your object, and then press the POWER/SCAN button to do a single measurement. You can press and hold the button to do a continuous measurement. (**Note:** In doing a single measurement, you should press and hold the POWER/SCAN button for at least 0.5s.)

- **Shutdown**

After starting up, if there is no operation over 15 seconds, the infrared thermometer will automatically shut down.

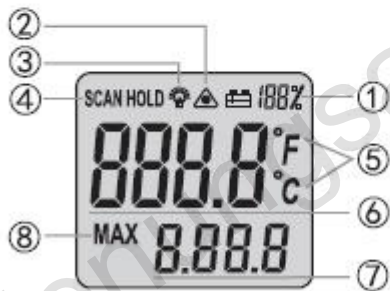
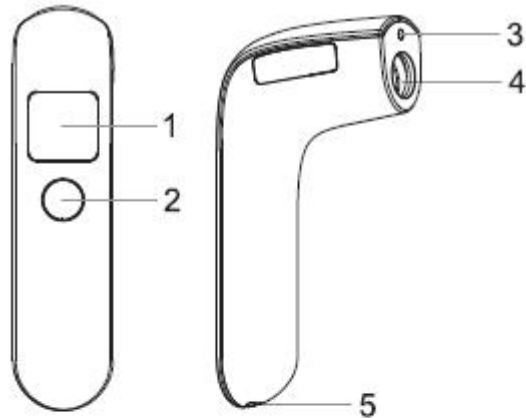

1. Display Screen
2. Power/Scan Button
3. Laser Hole
4. Infrared Sensor
5. Charging Port

- ① Battery Life
- ② Laser Icon
- ③ Backlight Icon
- ④ Scan & Hold Status
- ⑤ Temperature Unit
- ⑥ Measured Value
- ⑦ Maximum Value

⑧ Max Value Status

EMISSIVITY

The surface of most organic materials, and the surface of objects coated with oil paint and oxidized, has an emissivity of 0.95. Thus, we have preset the emissivity of the infrared thermometer as 0.95.

Shiny and polished metal will cause inaccurate measurement. Therefore, you should cover its surface with black tape or black oil paint, then measure the surface temperature of the tape or oil paint when both temperatures of the tape and cover material are in common.

NOTES IN USE

- Detecting shiny or polished metal surfaces like stainless steel and aluminum is not suggested.
- The measured results of non-ferrous metals, reflective objects, and transparent objects are inaccurate.
- It cannot measure the temperature through the surface of the glass. It can only detect the surface temperature of the glass.
- Particles like steam, dust, and smog will affect the measurement accuracy.

To prevent the thermometer and measuring objects from damages, please keep them away from the following:

- Objects like arc welding machines and induction-type heaters, because they will create electromagnetic fields.
- Thermal shock (it's caused by a larger or sudden change of environment temperature. Please wait for 20~30 minutes before use, let the thermometer reach a steady status).
- Please do not put the thermometer close to or on high-temperature objects.

DETECTING RANGE

The more distant the object is, the larger the detecting spot of the thermometer is. The relationship of size between distance and the detecting spot is commonly denoted by D:S, a ratio of distance and detecting spot size. When the distance is 36 cm, the diameter of the detecting spot is 3 cm. Therefore, the thermometer will display the average temperature of the detecting range of which diameter is 3.0 cm (as shown in figure 2).



图 2

MAINTENANCE

- Way To Clean Lens
Please use clean, compressed air to blow off inattentive particles. Then, please use a soft brusher to gently brush off residual chippings. After that, please use a wet cotton ball to carefully scrub the lens. Note: Do not use solvent to clean the laser lens.
- Way To Clean Shell
Please scrub the shell using a soft cloth dipping soap water. Note: Do not immerse the thermometer in the water.

SAFETY INSTRUCTION

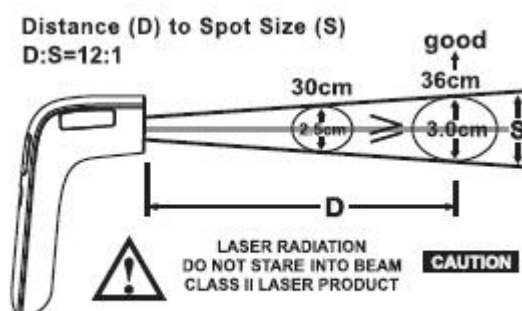
To prevent users from body damages, please conform to the following instructions:

- When using the infrared thermometer, please do not directly radiate the laser to human eyes or indirectly radiate from the reflective side.
- Before use, please check the thermometer and make sure it is not damaged or lacks plastic parts.
- Please replace the battery when a battery icon appears on the screen.
- If the thermometer is not working properly, do not use it. The protective measures of the thermometer may be broken. If you have any questions, you should send the device for repair.
- Please do not use the thermometer in a place close to explosive gases, steam, or dust.
- To prevent burning, please remember that the measured temperature is lower than the real temperature when you detect objects with high emissivity.
- If you do not use the thermometer according to this instruction, the protective measures of the thermometer may lose efficacy.

PRODUCT WARRANTY

This item carries a 1-year warranty against defects in either components or workmanship. During this period, products that prove to be defective will, at the discretion of INKBIRD, be either repaired or replaced without charge.

CUSTOMER SERVICE



INKBIRD TECH.C.L

Support@ink-bird.com
www.ink-bird.com
+86-0755-22747857
4/F E, Bldg 713, Pengji Industrial Zone,
Liantang St, Luohu Dist., Shenzhen, China.

