

KARIM'S & NOODLE WOK
KITCHEN@UNA



TRAVEL FOOD SERVICES

STATUS OF RELEASE:

FOR APPROVAL FOR TENDER
 FOR DISCUSSION FOR CONSTRUCTION

REV.	DATE	PREP BY	CHK BY	APPVD BY	REMARK

STAMP:

PROJECT NAME: #GRUB HUB@UNA

CLIENT NAME:

ARCHITECT: TFS

DRAWING TITLE: KARIM'S & NOODLE WOK @ UNA

DRAWING NO:

NORTH	DRAWING NO	Rev.

SCALE	DATE	PREP	CHKD	APPVD
	30-01-2024	NIROJ SHRIWAL	MANISH	RITUPARN SHARMA

KN-30	SS DUSTBIN BELOW	450Wx450Dx750H	1	Fabrication						
KN-31	HANDWASH SINK	600Wx700Dx850H+200 HIGH	1	Fabrication		450MM/FFL	YES			
KN-32	POTATO BIN (AS/SELECTION)	450Wx450Dx850H	1	Fabrication						
KN-34	WEIGHING MACHINE	AS/SELECTION	1	Boughtout	0.35	450MM/FFL				METIS
KN-35	ATTA BIN ON WHEEL	700Wx300Dx700H	1	Fabrication						
KN-36	MAIDA BIN ON WHEEL	700Wx300Dx700H	1	Fabrication						

BROUGHT OUT ITEMS:

KN-24	MIXER GRINDER (AS/SEL.)	SUJATA MAKE	1	Boughtout	2	1200MM				SUJATA
1	DRAIN THROUGH GRATING	300x300	6	OGT						
2	AIR CURTAIN (MITZVAH)	900WX300D	1	Boughtout						
3	FLY CATCHER	AS/SELECTION	2	Boughtout						
4	OGT	600Wx400Dx300H	1	OGT						
5	LONG BODY MIXER FOR DISHWASH SINK	AS/SELECTION	3	Boughtout						
6	JUICE DISPENSER	AS/SELECTION	1	Boughtout	0.5	1200MM				UGOLINI
7	LASSI DISPENSER	AS/SELECTION	1	Boughtout	0.5	1200MM				UGOLINI
TOTAL ELECTRIC LOAD (KW)					13.35					

NOTE:

1. All the dimension needs to be physically measured at site by the vendor before commencing the production..
2. G/N Pan Requirement will be shared by concerned brand.

1	3 BURNER RANGE	EXISTING OBS	1	EXISTING		450MM/FFL (RO)		GAS 250MM		
---	----------------	--------------	---	----------	--	----------------	--	-----------	--	--

EQUIPMENT NO: KN-02
 EQUIPMENT NAME: Hot Bain Marie 1/3 X9 GN PAN
 SIZE-: 1200WX700DX850HT.
 QTY-: 01
 BRAND:AS/SS
 MANUFACTURER SPEC.

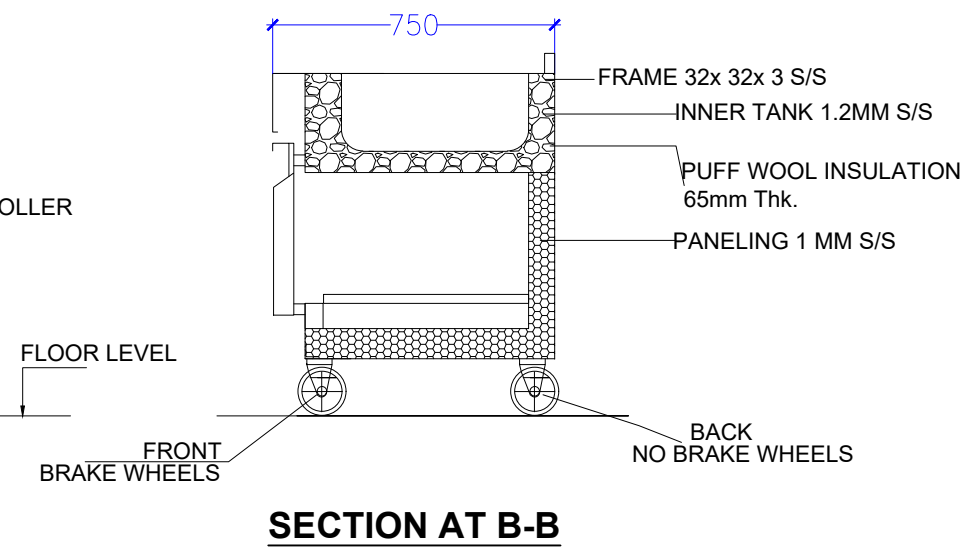
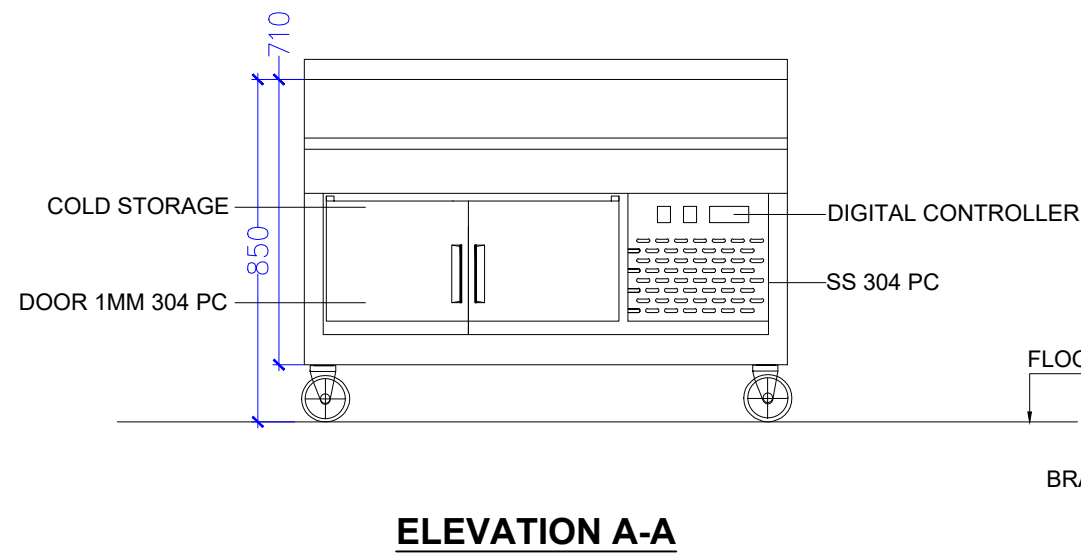
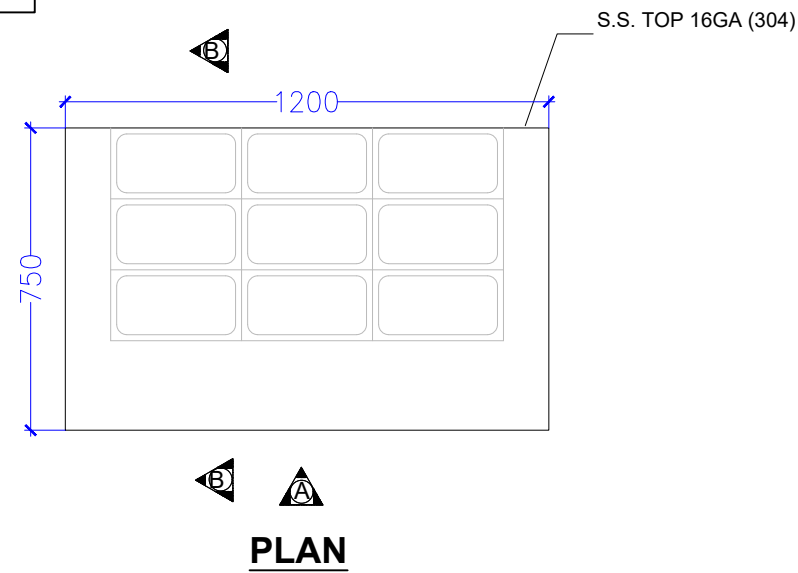

TRAVEL FOOD SERVICES

STATUS OF RELEASE:					
<input type="checkbox"/>	FOR APPROVAL	<input type="checkbox"/>	FOR TENDER		
<input checked="" type="checkbox"/>	FOR DISCUSSION	<input type="checkbox"/>	FOR CONSTRUCTION		
REV.	DATE	PREP BY	CHK BY	APPVD BY	REMARK

STAMP:	
PROJECT NAME:	UNA FOOD COURT
CLIENT NAME:	
ARCHITECT:	TFS

DRAWING TITLE:				
KARIM'S & NOODLE WOK KITCHEN				
DRAWING TITLE:				
KARIM'S & NOODLE WOK EQUIPMENT DETAIL				
NORTH	DRAWING NO			Rev.
SCALE	DATE	PREP	CHKD	APPVD
	29-07-2023	NIROJ SHRIWAL	NIROJ SHRIWAL	RITUPARN SHARMA

EQUIPMENT NO: KN-03

EQUIPMENT NAME: Cold
Bain Marie 1/6 X6 GN PAN

SIZE-: 1200WX700DX850HT.

QTY-: 01

BRAND:AS/SS

MANUFACTURER SPEC.

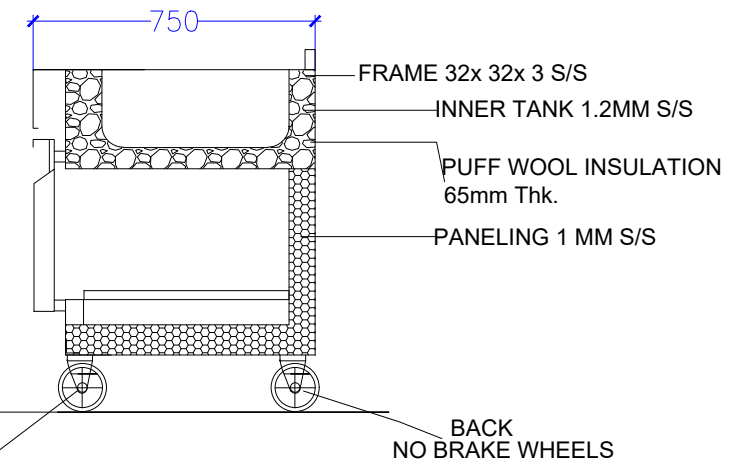
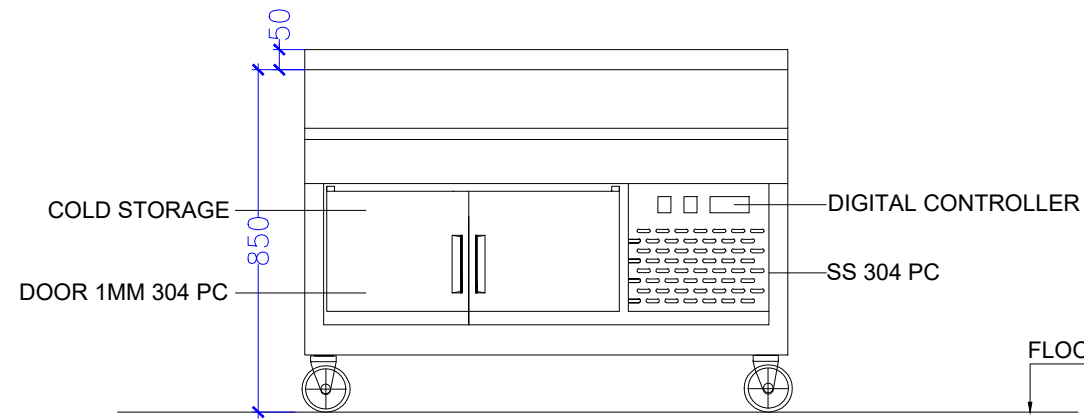
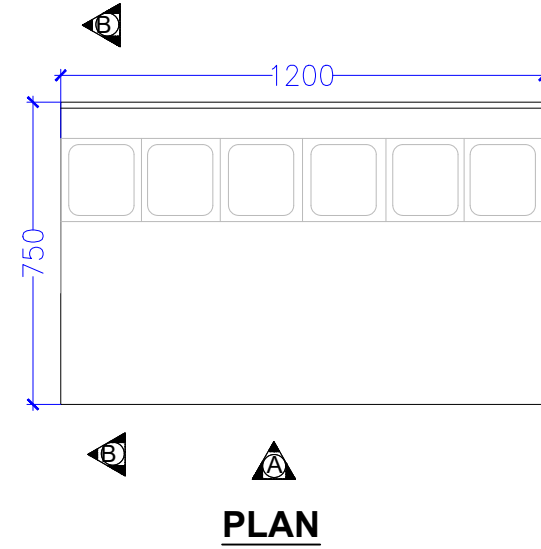

ELEVATION A-A

SECTION AT B-B

TRAVEL FOOD SERVICES

STATUS OF RELEASE:					
<input type="checkbox"/>	FOR APPROVAL	<input type="checkbox"/>	FOR TENDER		
<input checked="" type="checkbox"/>	FOR DISCUSSION	<input type="checkbox"/>	FOR CONSTRUCTION		
REV.	DATE	PREP BY	CHK BY	APPVD BY	REMARK

STAMP:	
PROJECT NAME:	UNA FOOD COURT
CLIENT NAME:	
ARCHITECT:	TFS

DRAWING TITLE:				
KARIM'S & NOODLE WOK KITCHEN				
DRAWING TITLE:				
KARIM'S & NOODLE WOK EQUIPMENT DETAIL				
NORTH	DRAWING NO			Rev.
SCALE	DATE	PREP	CHKD	APPVD
	29-07-2023	NIROJ SHRIWAL	NIROJ SHRIWAL	RITUPARN SHARMA

EQUIPMENT NO: KN-04

EQUIPMENT NAME: SS Work counter with under shelves

SIZE-: 450WX700DX850HT.

QTY-: 01

BRAND: AS/SS

MANUFACTURER SPEC.

EQUIPMENT NO: KN-04B

EQUIPMENT NAME: SS Work counter with under shelves

SIZE-: 450WX900DX850HT.

QTY-: 02

BRAND: AS/SS

MANUFACTURER SPEC.

EQUIPMENT NO: KN-04A

EQUIPMENT NAME: SS DUSTBIN

SIZE-: 450WX450DX850HT.

QTY-: 01

BRAND: AS/SS

MANUFACTURER SPEC.

TOP MADE OF 16G SS304 SS SHEET
SPLASH OF REAR SIDES 50MM HIGH

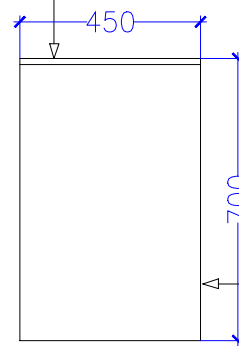

TOP SECURED WITH SS ANGLE SS304
40X40X3MM THK

PLAN

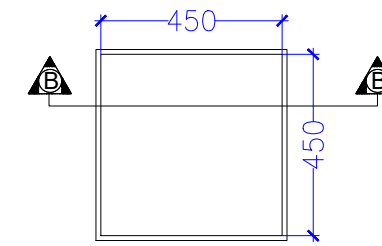

PLAN

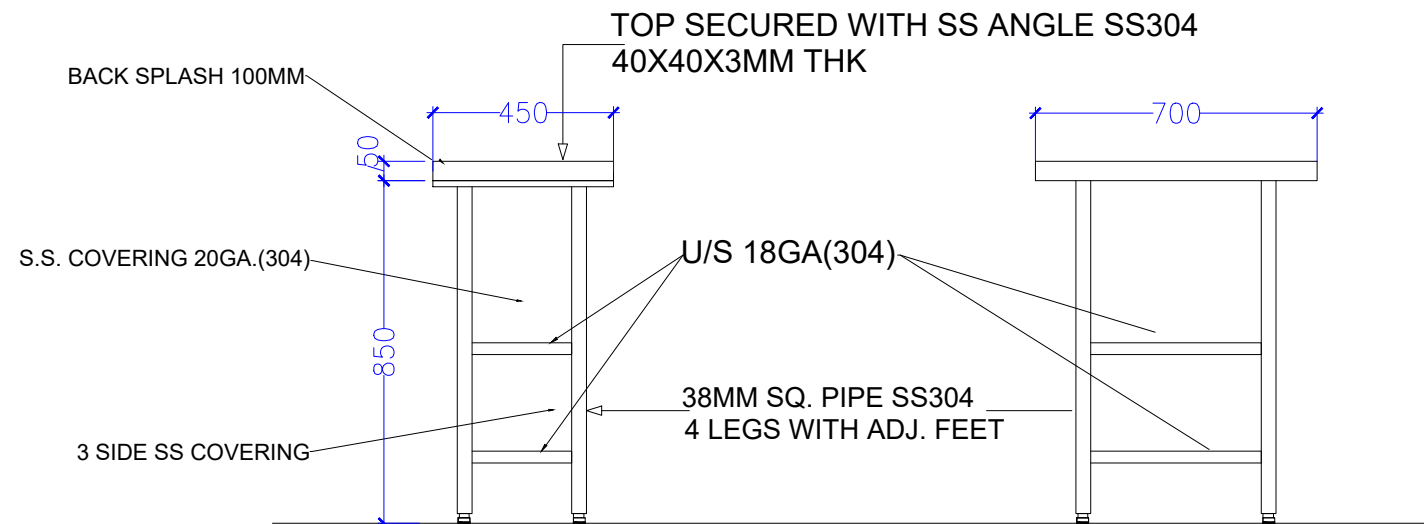

ELEVATION A

ELEVATION B

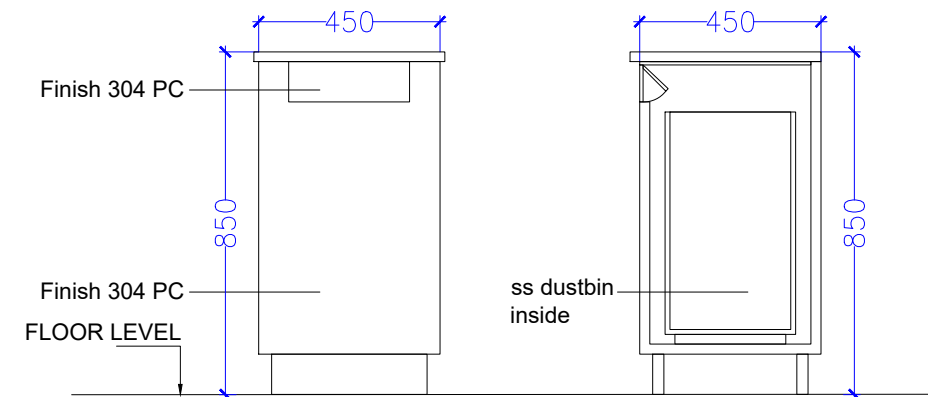

ELEVATION A

SECTION

TRAVEL FOOD SERVICES

STATUS OF RELEASE:					
<input type="checkbox"/>	FOR APPROVAL	<input type="checkbox"/>	FOR TENDER		
<input checked="" type="checkbox"/>	FOR DISCUSSION	<input type="checkbox"/>	FOR CONSTRUCTION		
REV.	DATE	PREP BY	CHK BY	APPVD BY	REMARK

STAMP:	
PROJECT NAME:	UNA FOOD COURT
CLIENT NAME:	
ARCHITECT:	TFS

DRAWING TITLE:				
KARIM'S & NOODLE WOK KITCHEN				
DRAWING TITLE: KARIM'S & NOODLE WOK EQUIPMENT DETAIL				
NORTH	DRAWING NO	Rev.		
SCALE	DATE	PREP	CHKD	APPVD
	29-07-2023	NIROJ SHRIWAL	NIROJ SHRIWAL	RITUPARN SHARMA

EQUIPMENT NO: KN-05
 EQUIPMENT NAME: Hot Bain Marie 1/3 X6 GN PAN
 SIZE:- 900WX700X850HT.
 QTY:- 01
 BRAND:AS/SS
 MANUFACTURER SPEC.

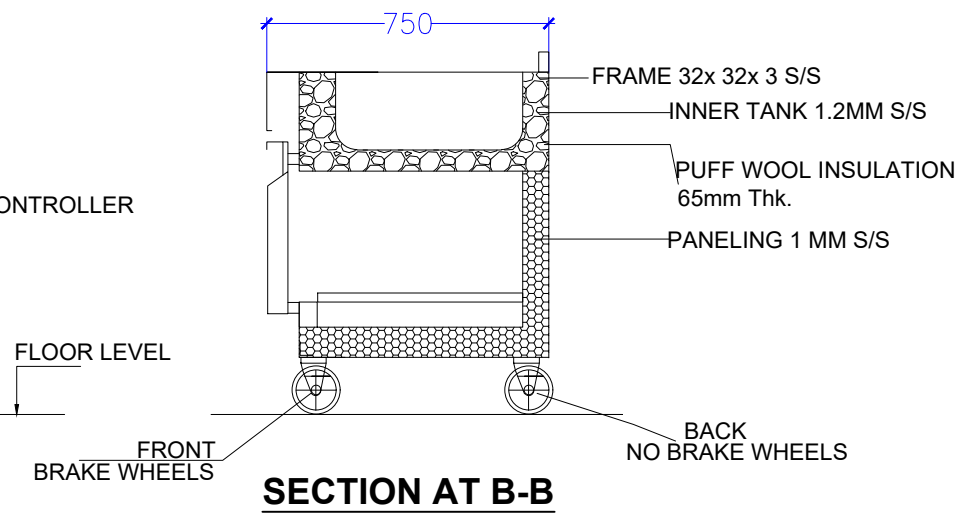
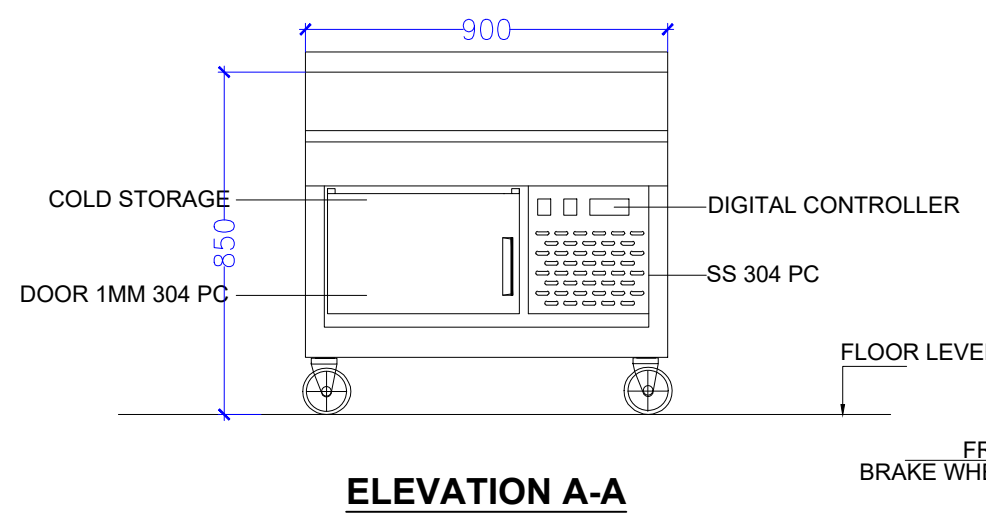
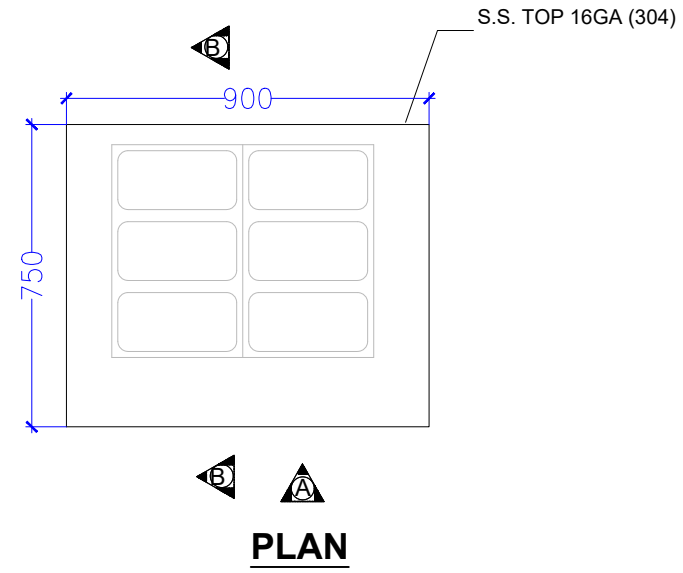

TRAVEL FOOD SERVICES

STATUS OF RELEASE:					
<input type="checkbox"/>	FOR APPROVAL	<input type="checkbox"/>	FOR TENDER		
<input checked="" type="checkbox"/>	FOR DISCUSSION	<input type="checkbox"/>	FOR CONSTRUCTION		
REV.	DATE	PREP BY	CHK BY	APPVD BY	REMARK

STAMP:	
PROJECT NAME:	UNA FOOD COURT
CLIENT NAME:	
ARCHITECT:	TFS

DRAWING TITLE:				
KARIM'S & NOODLE WOK KITCHEN				
DRAWING TITLE:				
KARIM'S & NOODLE WOK EQUIPMENT DETAIL				
NORTH	DRAWING NO			Rev.
SCALE	DATE	PREP	CHKD	APPVD
	29-07-2023	NIROJ SHRIWAL	NIROJ SHRIWAL	RITUPARN SHARMA

EQUIPMENT NO: KN-06
 EQUIPMENT NAME: SS Work counter with under shelves
 SIZE-: 750WX700X850HT.
 QTY-: 01
 BRAND: AS/SS
 MANUFACTURER SPEC.

TOP MADE OF 16G SS304 SS SHEET
 SPLASH OF REAR SIDES 50MM HIGH

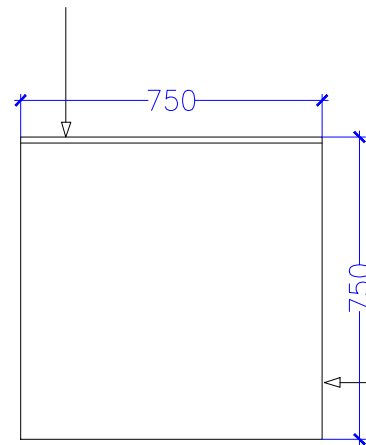

PLAN

TOP SECURED WITH SS ANGLE SS304
 40X40X3MM THK

TOP SECURED WITH SS ANGLE SS304
 40X40X3MM THK

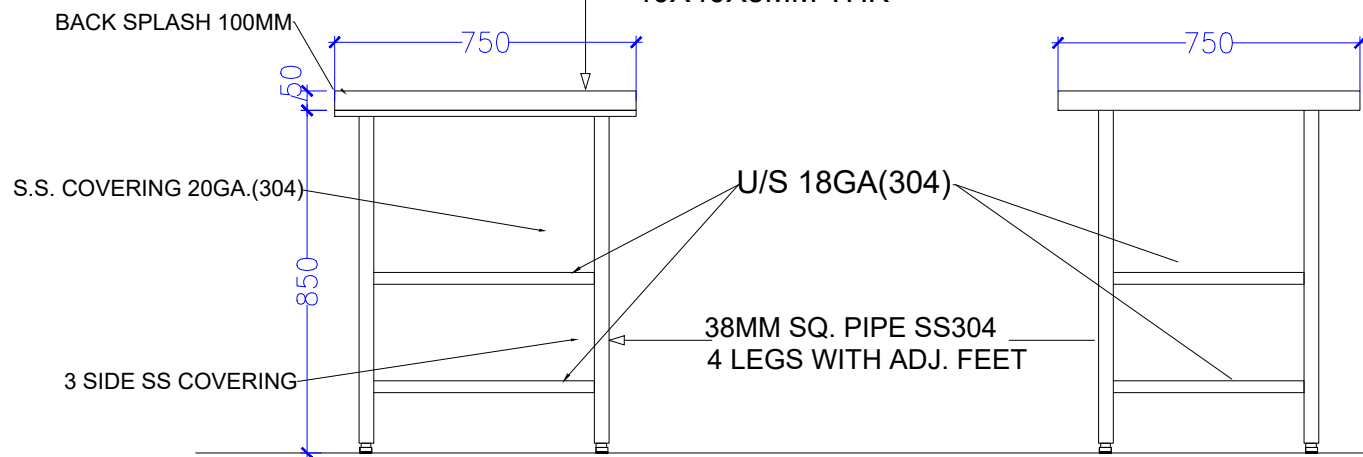

ELEVATION A

ELEVATION B

EQUIPMENT NO: KN-07
 EQUIPMENT NAME: Visi Cooler
 SIZE-: 580WX620DX1800HT.
 QTY-: 02
 BRAND: BLUESTAR

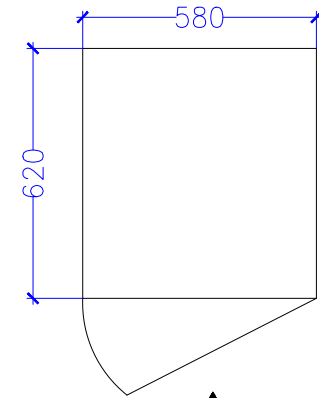

PLAN

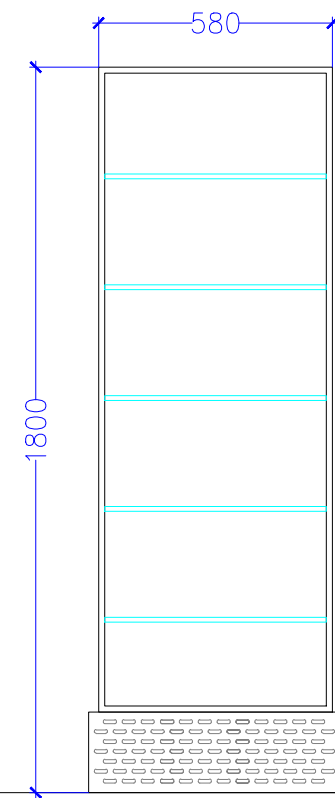

ELEVATION A

TRAVEL FOOD SERVICES

STATUS OF RELEASE:					
<input type="checkbox"/>	FOR APPROVAL	<input type="checkbox"/>	FOR TENDER		
<input checked="" type="checkbox"/>	FOR DISCUSSION	<input type="checkbox"/>	FOR CONSTRUCTION		
REV.	DATE	PREP BY	CHK BY	APPVD BY	REMARK

STAMP:	
PROJECT NAME:	UNA FOOD COURT
CLIENT NAME:	
ARCHITECT:	TFS

DRAWING TITLE:				
KARIM'S & NOODLE WOK KITCHEN				
DRAWING TITLE:				
KARIM'S & NOODLE WOK EQUIPMENT DETAIL				
NORTH	DRAWING NO			Rev.
SCALE	DATE	PREP	CHKD	APPVD
	29-07-2023	NIROJ SHRIWAL	NIROJ SHRIWAL	RITUPARN SHARMA

EQUIPMENT NO: KN-08
 EQUIPMENT NAME: SS Work counter with under shelves
 SIZE-: 1500WX700X850HT.
 QTY-: 01
 BRAND: AS/SS
 MANUFACTURER SPEC.

TOP MADE OF 16G SS304 SS SHEET
 SPLASH OF REAR SIDES 50MM HIGH

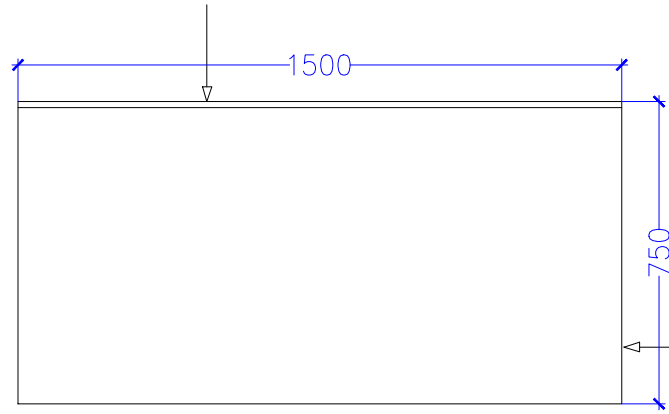

TOP SECURED WITH SS ANGLE SS304
 40X40X3MM THK

PLAN

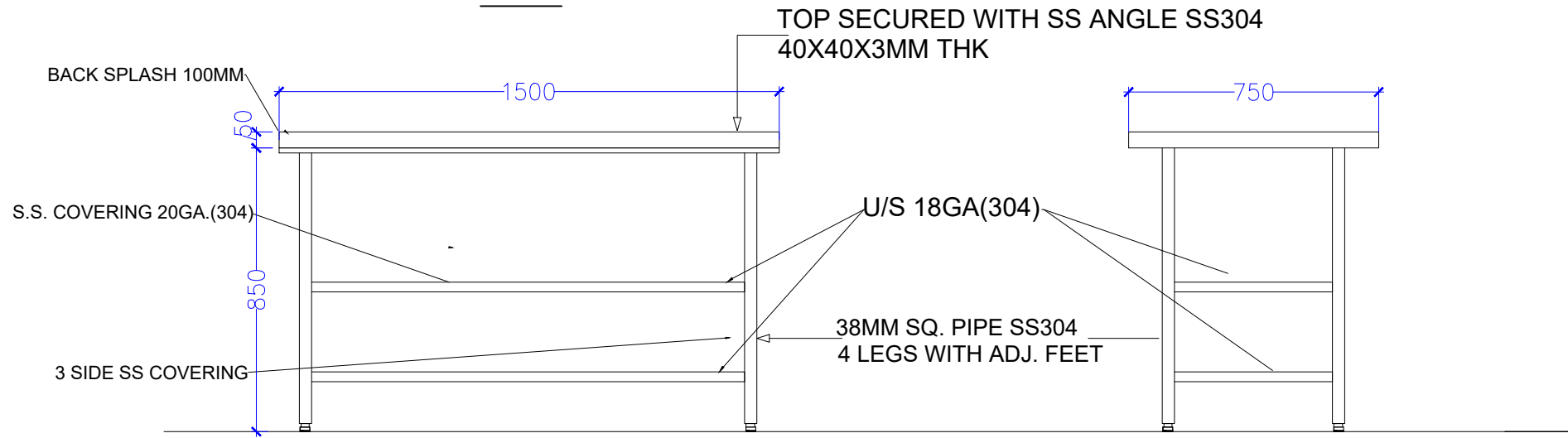

ELEVATION A

ELEVATION B

TRAVEL FOOD SERVICES

STATUS OF RELEASE:					
<input type="checkbox"/>	FOR APPROVAL	<input type="checkbox"/>	FOR TENDER		
<input checked="" type="checkbox"/>	FOR DISCUSSION	<input type="checkbox"/>	FOR CONSTRUCTION		
REV.	DATE	PREP BY	CHK BY	APPVD BY	REMARK

STAMP:	
PROJECT NAME:	UNA FOOD COURT
CLIENT NAME:	
ARCHITECT:	TFS

DRAWING TITLE:				
KARIM'S & NOODLE WOK KITCHEN				
DRAWING TITLE:				
KARIM'S & NOODLE WOK EQUIPMENT DETAIL				
NORTH	DRAWING NO			Rev.
SCALE	DATE	PREP	CHKD	APPVD
	29-07-2023	NIROJ SHRIWAL	NIROJ SHRIWAL	RITUPARN SHARMA

EQUIPMENT NO: KN-09

EQUIPMENT NAME: Under Counter Ref.(0 to 4°) with SS Work Counter Top for Food Dispensing
 SIZE-: 1500WX700X850HT.
 QTY-: 01
 BRAND: BLUESTAR
 MANUFACTURER SPEC.

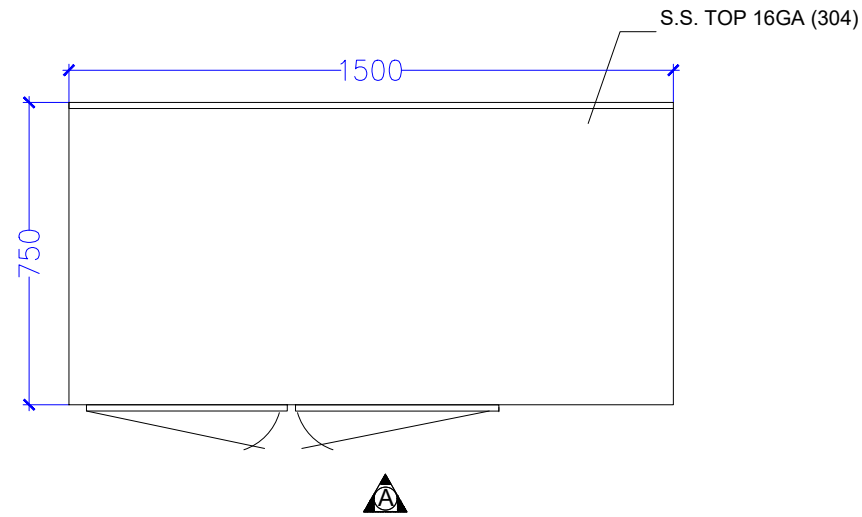

PLAN

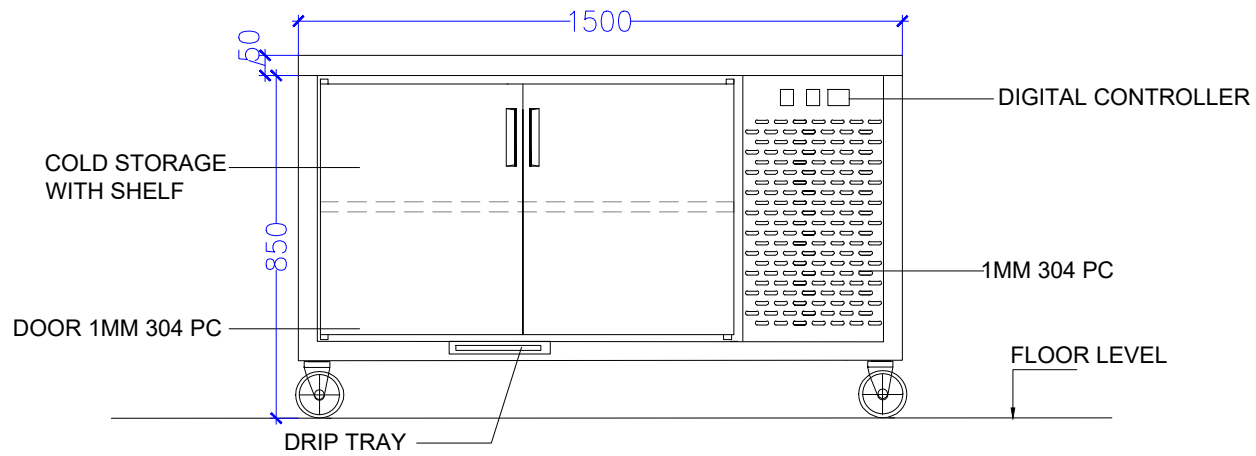

ELEVATION A

EQUIPMENT NO: KN-10 & KN-10A

EQUIPMENT NAME: Under Counter Ref.(0 to 4°) with SS Work Counter Top for Food Dispensing & Overhead Shelf
 SIZE-: 1200WX700X850HT.
 QTY-: 01
 BRAND: BLUESTAR
 MANUFACTURER SPEC.

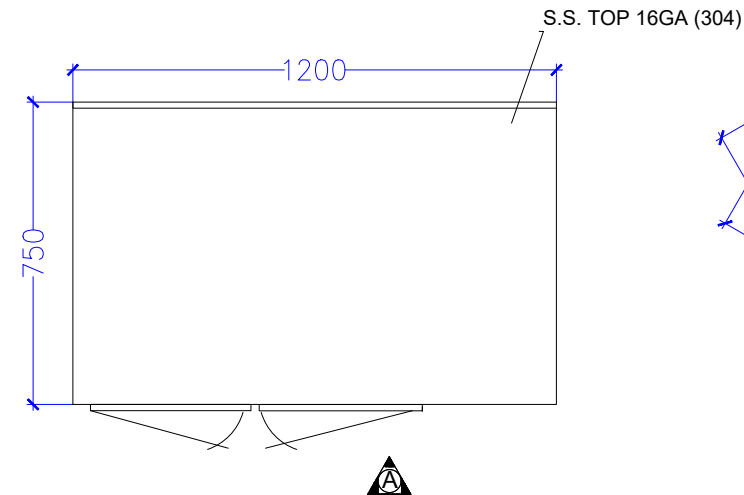

PLAN

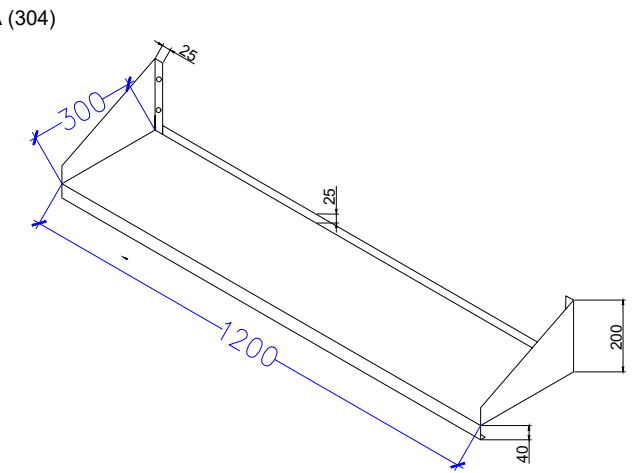

OVERHEAD SHELF

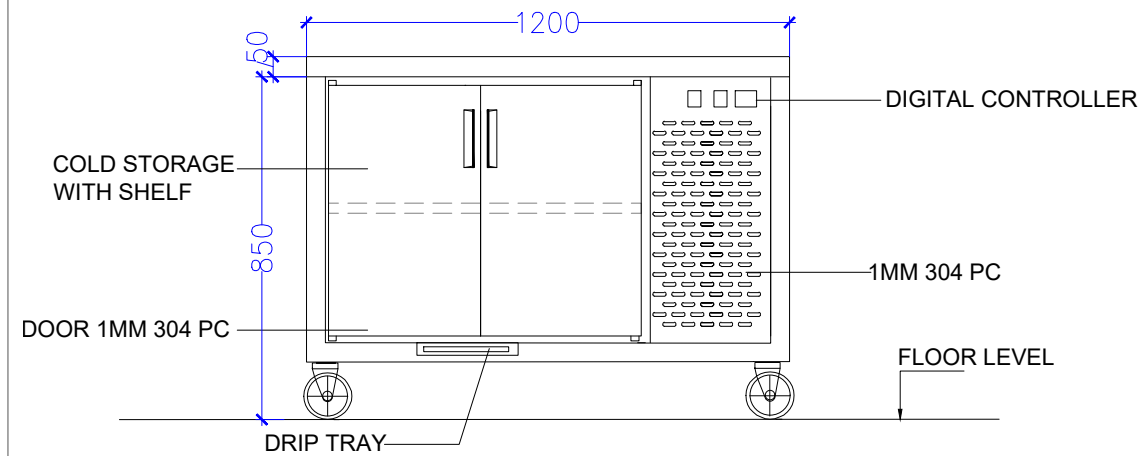

ELEVATION A

TRAVEL FOOD SERVICES

STATUS OF RELEASE:
 FOR APPROVAL FOR TENDER
 FOR DISCUSSION FOR CONSTRUCTION

REV.	DATE	PREP BY	CHK BY	APPVD BY	REMARK

STAMP:
 PROJECT NAME: **UNA FOOD COURT**
 CLIENT NAME:
 ARCHITECT: **TFS**

DRAWING TITLE: KARIM'S & NOODLE WOK KITCHEN				
DRAWING TITLE: KARIM'S & NOODLE WOK EQUIPMENT DETAIL				
NORTH	DRAWING NO			Rev.
SCALE	DATE	PREP	CHKD	APPVD
	29-07-2023	NIROJ SHRIWAL	NIROJ SHRIWAL	RITUPARN SHARMA

EQUIPMENT NO: KN-11 &
KN-11A

EQUIPMENT NAME: Under
refrigerator with 1/3 X5 GN PAN
& overhead shelf

SIZE-: 900WX700X850HT.

QTY-: 01

BRAND:AS/SS

MANUFACTURER SPEC.

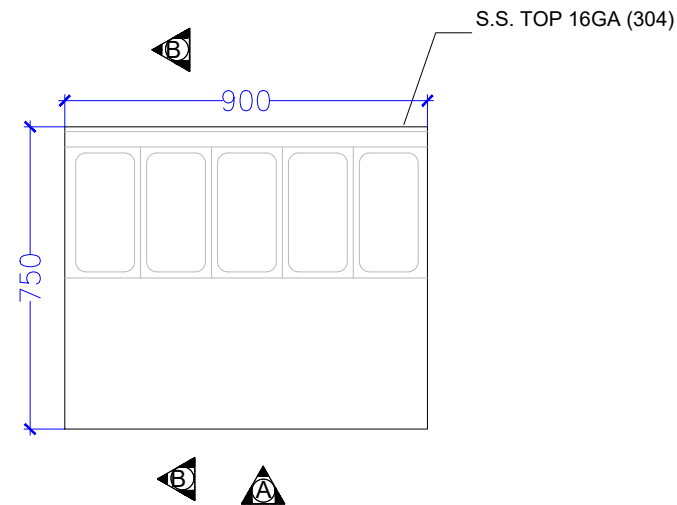

PLAN

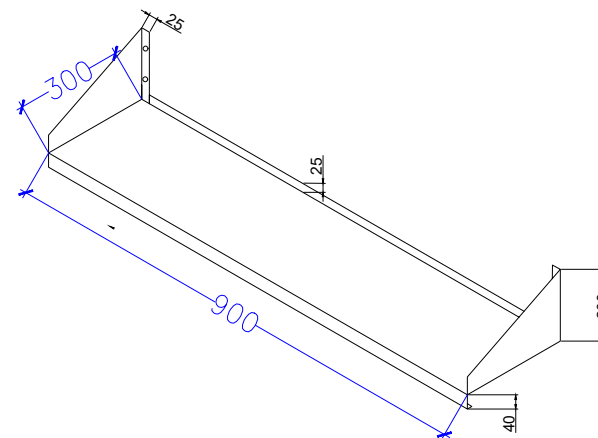

OVERHEAD SHELF

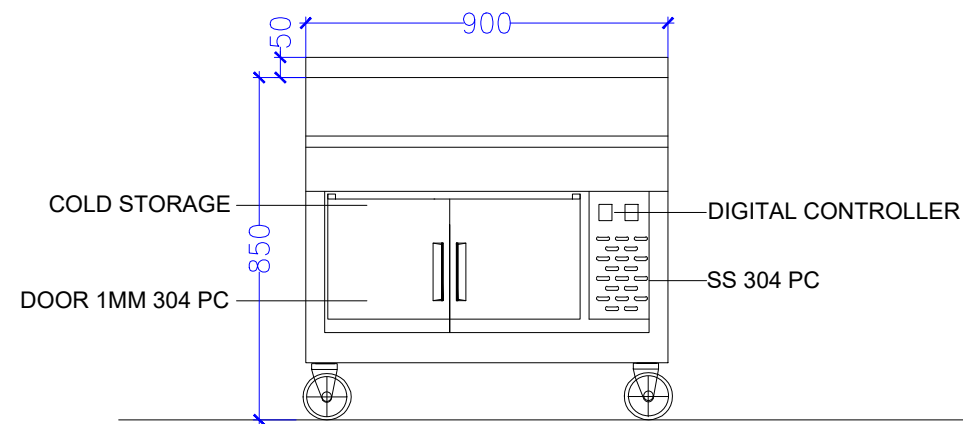

ELEVATION A-A

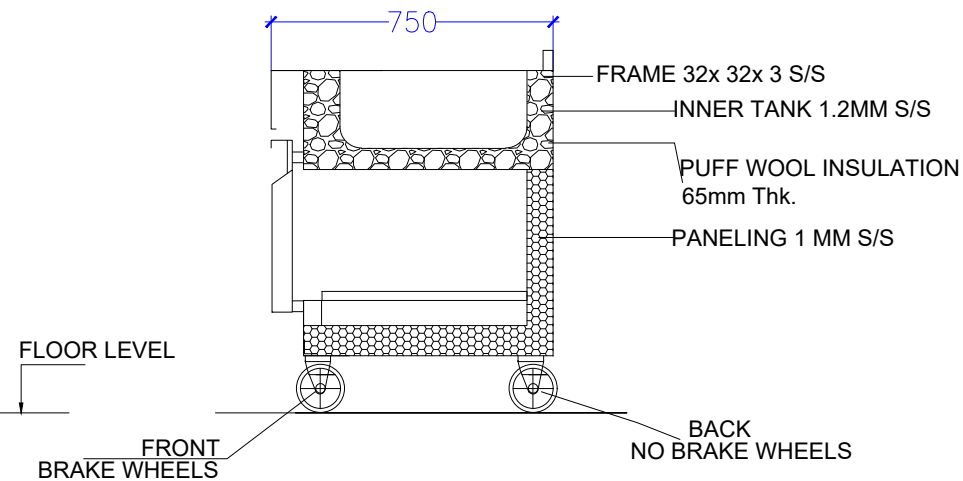

SECTION AT B-B

TRAVEL FOOD SERVICES

STATUS OF RELEASE:
 FOR APPROVAL FOR TENDER
 FOR DISCUSSION FOR CONSTRUCTION

REV.	DATE	PREP BY	CHK BY	APPVD BY	REMARK

STAMP:
 PROJECT NAME: **UNA FOOD COURT**
 CLIENT NAME:
 ARCHITECT: **TFS**

DRAWING TITLE: KARIM'S & NOODLE WOK KITCHEN				
DRAWING TITLE: KARIM'S & NOODLE WOK EQUIPMENT DETAIL				
NORTH	DRAWING NO			Rev.
SCALE	DATE	PREP	CHKD	APPVD
	29-07-2023	NIROJ SHRIWAL	NIROJ SHRIWAL	RITUPARN SHARMA

EQUIPMENT NO: KN-13

EQUIPMENT NAME: Two Door Freezer (0 to 4°) Temp.

SIZE-: 740WX830DX2000HT.

QTY-: 02

BRAND: CELFROST

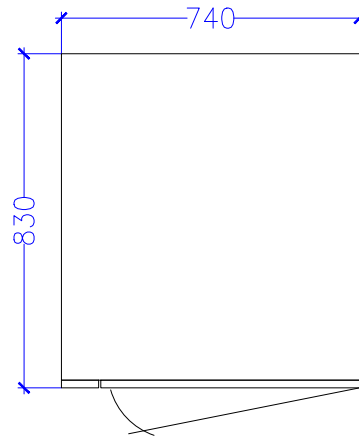

PLAN

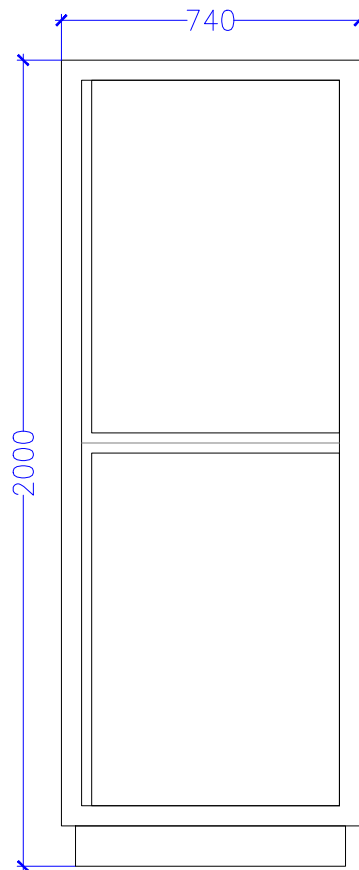

ELEVATION

EQUIPMENT NO: KN-14

EQUIPMENT NAME: Two Door Freezer (-20°) Temp.

SIZE-: 740WX830DX2000HT.

QTY-: 02

BRAND: CELFROST

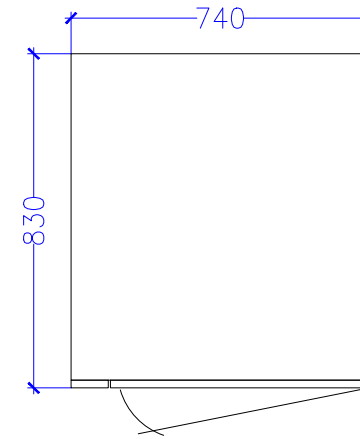

PLAN

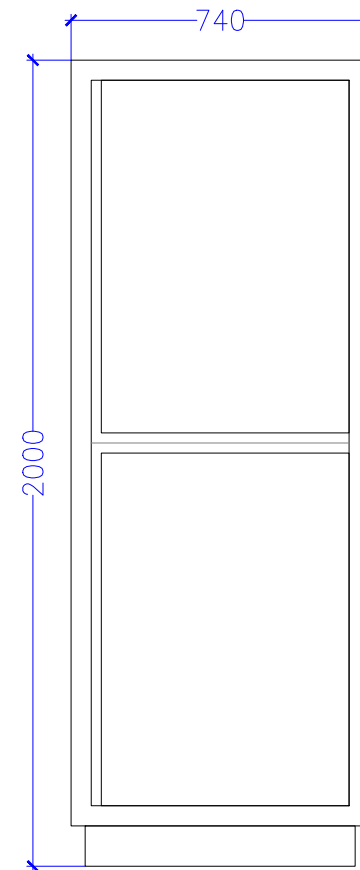

ELEVATION

TRAVEL FOOD SERVICES

STATUS OF RELEASE:

- FOR APPROVAL FOR TENDER
 FOR DISCUSSION FOR CONSTRUCTION

REV.	DATE	PREP BY	CHK BY	APPVD BY	REMARK

STAMP:

PROJECT NAME:

UNA FOOD COURT

CLIENT NAME:

ARCHITECT:

TFS

DRAWING TITLE:

KARIM'S & NOODLE WOK KITCHEN

DRAWING TITLE:

KARIM'S & NOODLE WOK EQUIPMENT DETAIL

NORTH	DRAWING NO			Rev.
SCALE	DATE	PREP	CHKD	APPVD
	29-07-2023	NIROJ SHRIWAL	NIROJ SHRIWAL	RITUPARN SHARMA

EQUIPMENT NO: KN-15

EQUIPMENT NAME: Gas Tandoor

SIZE-: 800WX900X850HT.

QTY-: 01
 BRAND: AS/SS
 MANUFACTURER SPEC.

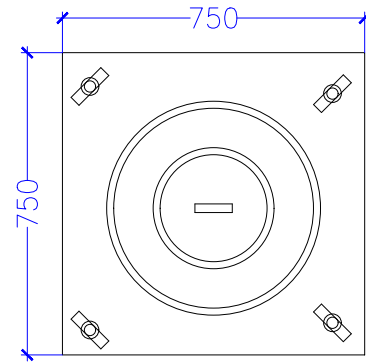

PLAN

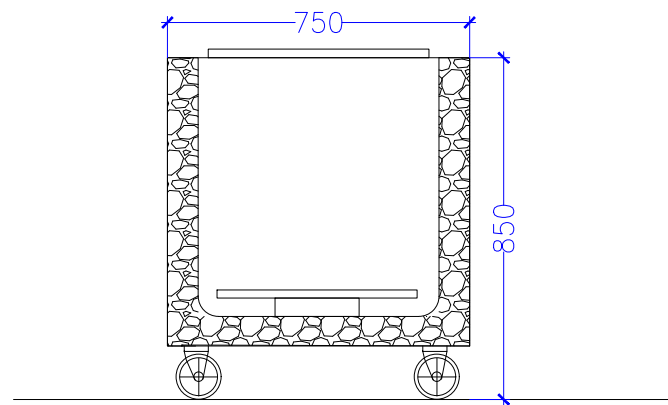

ELEVATION A

EQUIPMENT NO: KN-16

EQUIPMENT NAME: Two Burner Range

SIZE-: 1200WX700X850HT.

QTY-: 01
 BRAND: AS/SS
 MANUFACTURER SPEC.

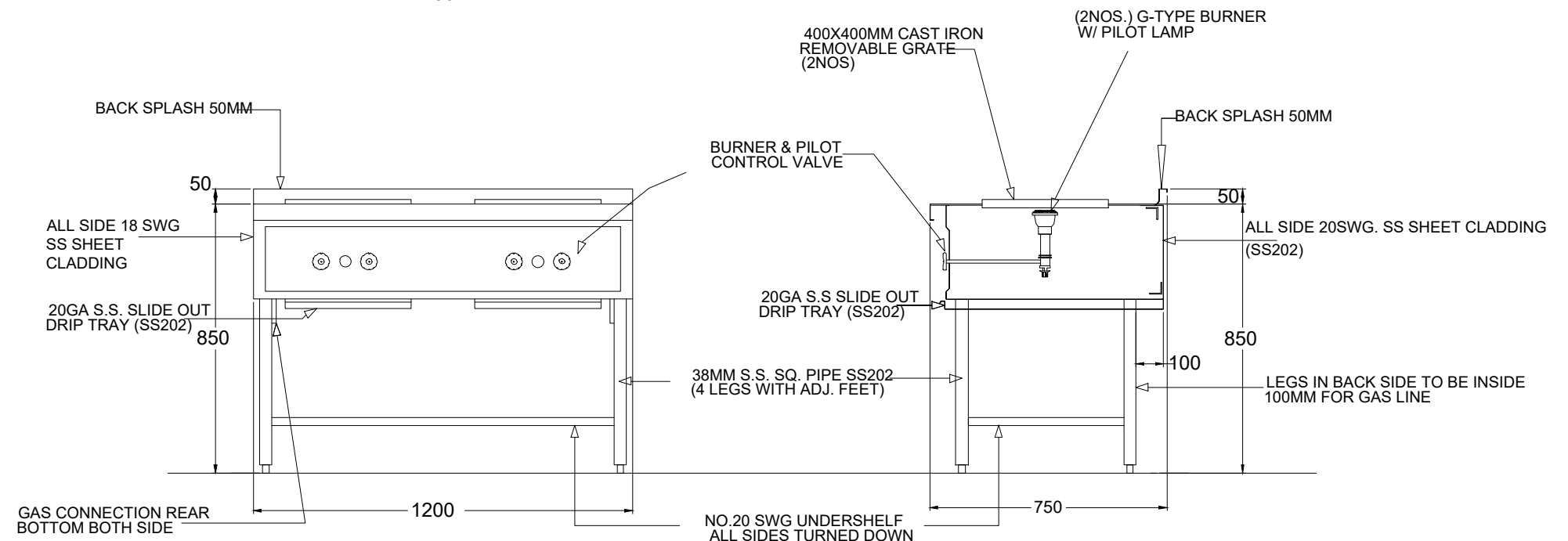
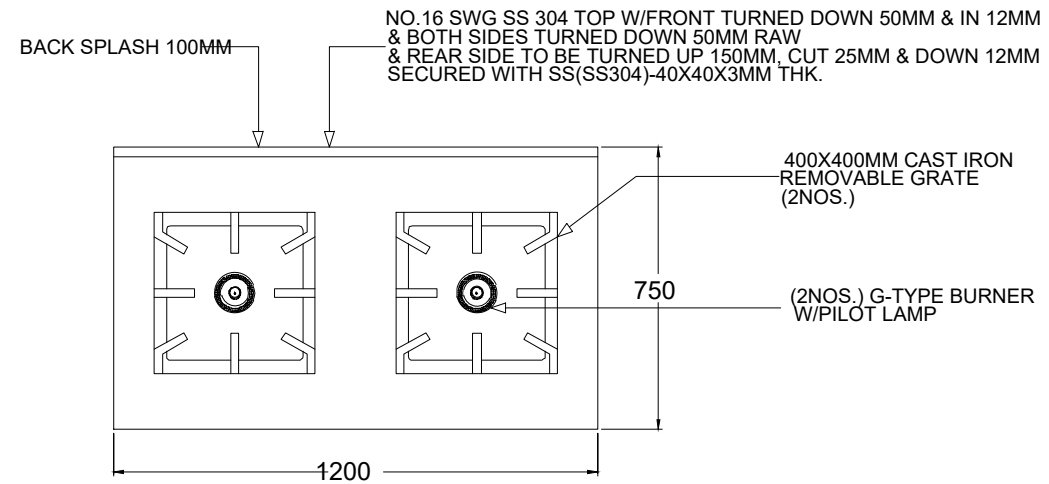

TRAVEL FOOD SERVICES

STATUS OF RELEASE:					
<input type="checkbox"/>	FOR APPROVAL	<input type="checkbox"/>	FOR TENDER		
<input checked="" type="checkbox"/>	FOR DISCUSSION	<input type="checkbox"/>	FOR CONSTRUCTION		
REV.	DATE	PREP BY	CHK BY	APPVD BY	REMARK

STAMP:	
PROJECT NAME:	UNA FOOD COURT
CLIENT NAME:	
ARCHITECT:	TFS

DRAWING TITLE:				
KARIM'S & NOODLE WOK KITCHEN				
DRAWING TITLE:				
KARIM'S & NOODLE WOK EQUIPMENT DETAIL				
NORTH	DRAWING NO			Rev.
SCALE	DATE	PREP	CHKD	APPVD
	29-07-2023	NIROJ SHRIWAL	NIROJ SHRIWAL	RITUPARN SHARMA

EQUIPMENT NO: KN-17

EQUIPMENT NAME:
EXHAUST HOOD

SIZE-: 4550WX900D

QTY-: 01
BRAND: AS/SS
MANUFACTURER SPEC.

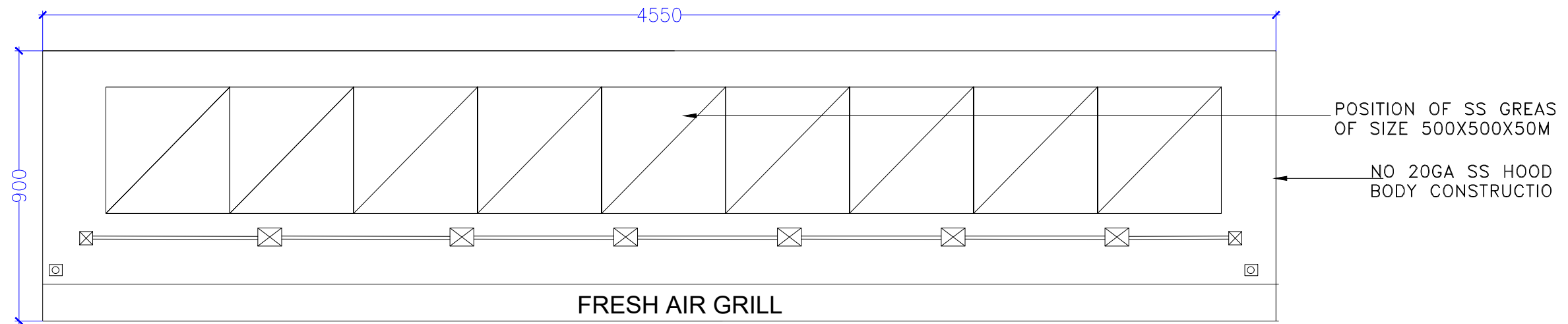
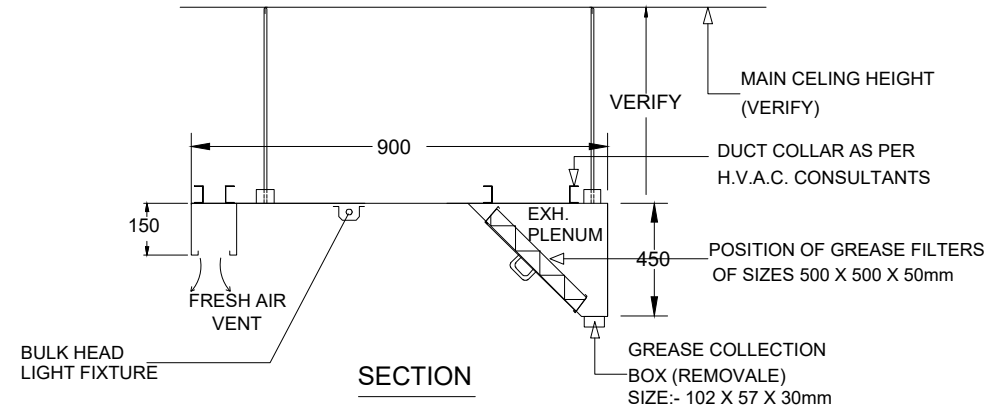

TOP VIEW

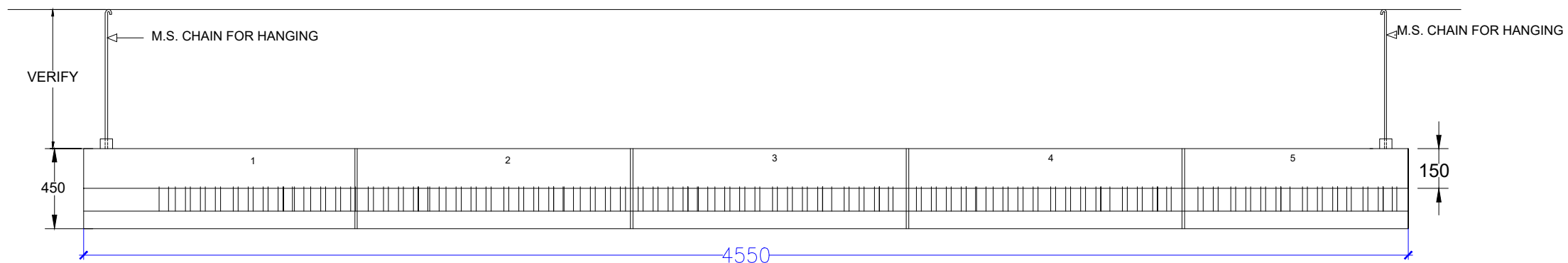

ELEVATION

TRAVEL FOOD SERVICES

STATUS OF RELEASE:					
<input type="checkbox"/>	FOR APPROVAL	<input type="checkbox"/>	FOR TENDER		
<input checked="" type="checkbox"/>	FOR DISCUSSION	<input type="checkbox"/>	FOR CONSTRUCTION		
REV.	DATE	PREP BY	CHK BY	APPVD BY	REMARK

STAMP:	
PROJECT NAME:	UNA FOOD COURT
CLIENT NAME:	
ARCHITECT:	TFS

DRAWING TITLE:				
KARIM'S & NOODLE WOK KITCHEN				
DRAWING TITLE:				
KARIM'S & NOODLE WOK EQUIPMENT DETAIL				
NORTH	DRAWING NO			Rev.
SCALE	DATE	PREP	CHKD	APPVD
	29-07-2023	NIROJ SHRIWAL	NIROJ SHRIWAL	RITUPARN SHARMA

EQUIPMENT NO: KN-19A
 EQUIPMENT NAME:
 EXHAUST HOOD
 SIZE-: 4350WX900D
 QTY-: 01
 BRAND: AS/SS
 MANUFACTURER SPEC.

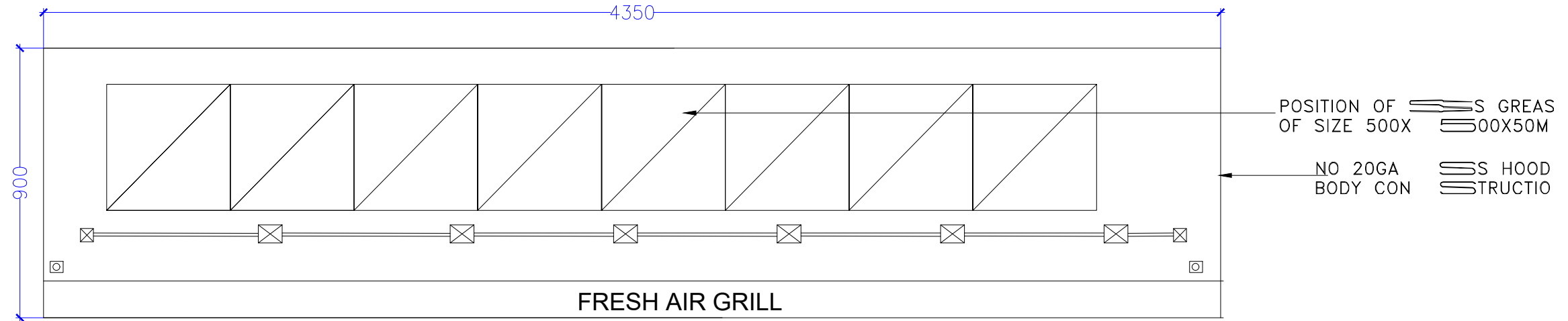
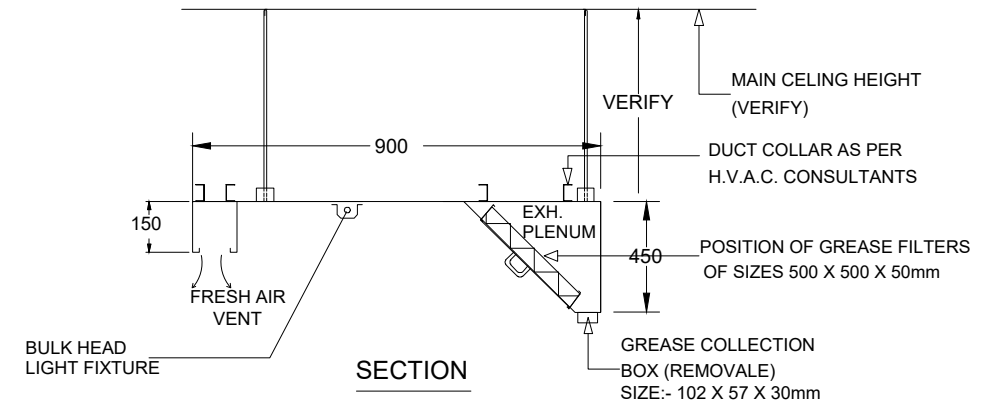

TOP VIEW

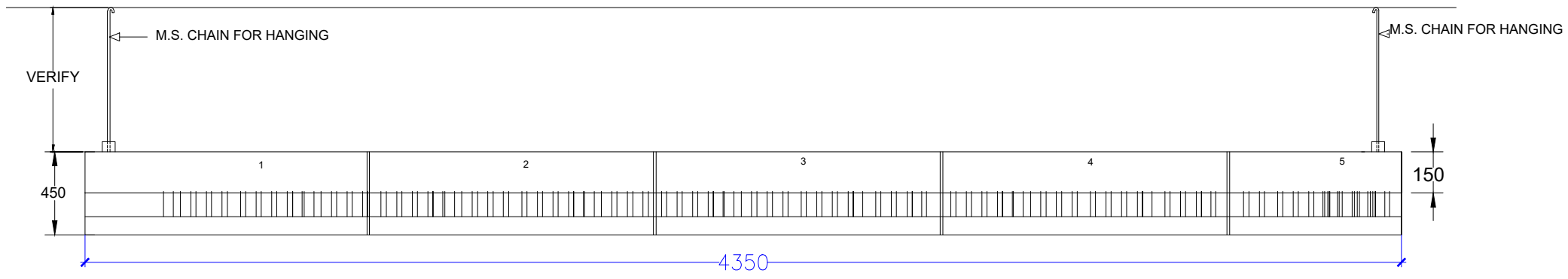

TRAVEL FOOD SERVICES

STATUS OF RELEASE:					
<input type="checkbox"/>	FOR APPROVAL	<input type="checkbox"/>	FOR TENDER		
<input checked="" type="checkbox"/>	FOR DISCUSSION	<input type="checkbox"/>	FOR CONSTRUCTION		
REV.	DATE	PREP BY	CHK BY	APPVD BY	REMARK

STAMP:	
PROJECT NAME:	UNA FOOD COURT
CLIENT NAME:	
ARCHITECT:	TFS

DRAWING TITLE:				
KARIM'S & NOODLE WOK KITCHEN				
DRAWING TITLE:				
KARIM'S & NOODLE WOK EQUIPMENT DETAIL				
NORTH	DRAWING NO			Rev.
SCALE	DATE	PREP	CHKD	APPVD
	29-07-2023	NIROJ SHRIWAL	NIROJ SHRIWAL	RITUPARN SHARMA

EQUIPMENT NO: KN-20

EQUIPMENT NAME: Chinese
Cooking Range

SIZE-: 1050WX700X850HT.

QTY-: 01

BRAND: AS/SS

MANUFACTURER SPEC.

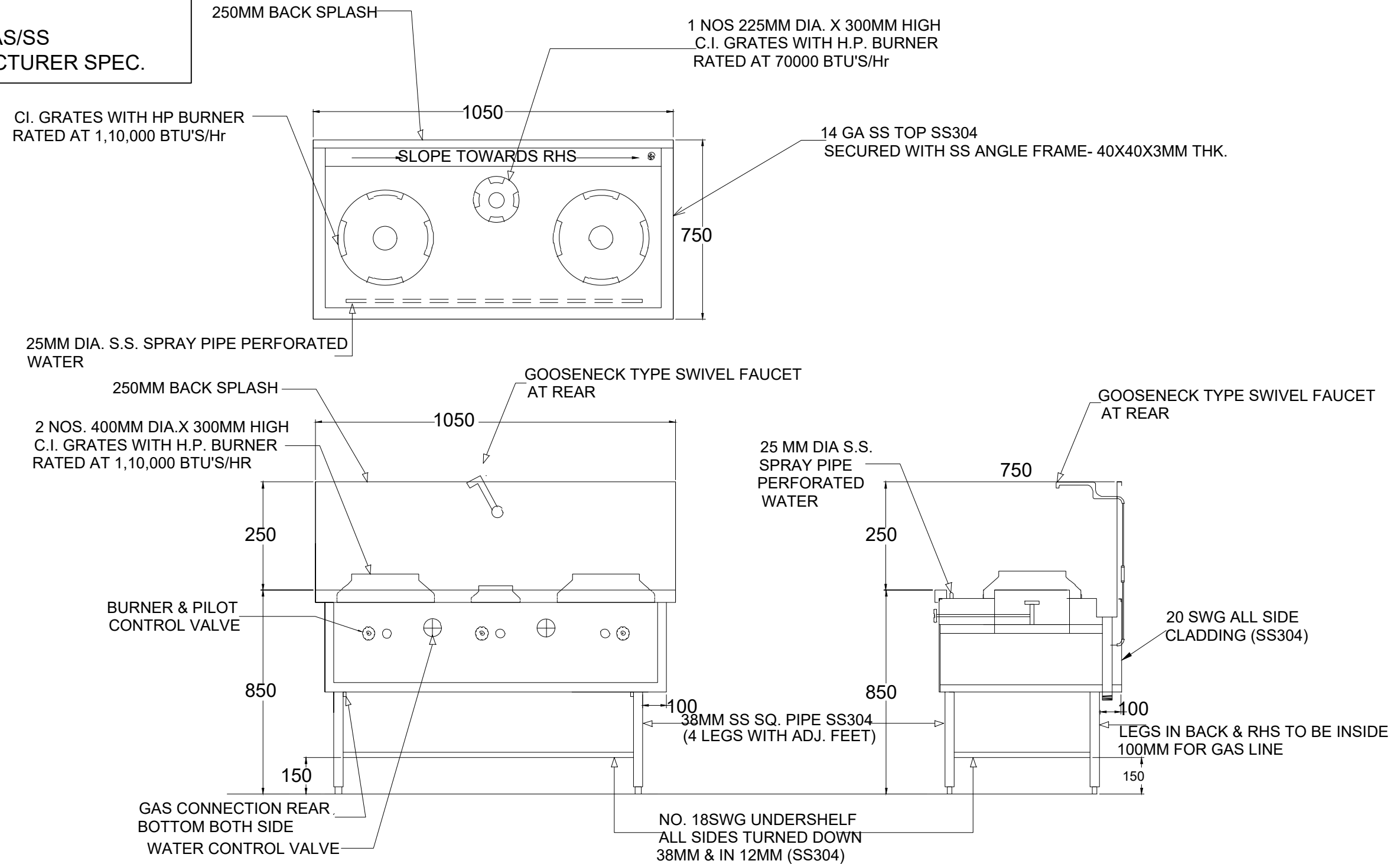

TRAVEL FOOD SERVICES

STATUS OF RELEASE:					
<input type="checkbox"/>	FOR APPROVAL	<input type="checkbox"/>	FOR TENDER		
<input checked="" type="checkbox"/>	FOR DISCUSSION	<input type="checkbox"/>	FOR CONSTRUCTION		
REV.	DATE	PREP BY	CHK BY	APPVD BY	REMARK

STAMP:	
PROJECT NAME:	UNA FOOD COURT
CLIENT NAME:	
ARCHITECT:	TFS

DRAWING TITLE:				
KARIM'S & NOODLE WOK KITCHEN				
DRAWING TITLE:				
KARIM'S & NOODLE WOK EQUIPMENT DETAIL				
NORTH	DRAWING NO			Rev.
SCALE	DATE	PREP	CHKD	APPVD
	29-07-2023	NIROJ SHRIWAL	NIROJ SHRIWAL	RITUPARN SHARMA

EQUIPMENT NO: KN-21
 EQUIPMENT NAME: Table with Insert
 SIZE-: 300WX700X850H
 QTY-: 01
 BRAND: AS/SS
 MANUFACTURER SPEC.

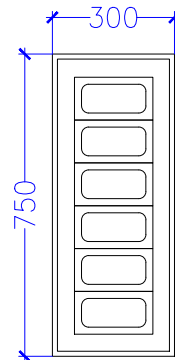

EQUIPMENT NO: KN-22
 EQUIPMENT NAME: Under Counter Ref.(0 to 4°) with 1/3X7 GN PAN & Overhead Shelf
 SIZE-: 1350WX700X850HT.
 QTY-: 01
 BRAND: BLUESTAR
 MANUFACTURER SPEC.

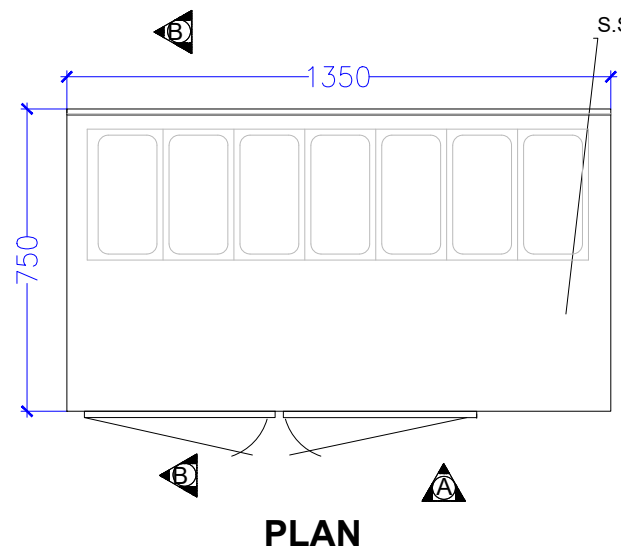

PLAN

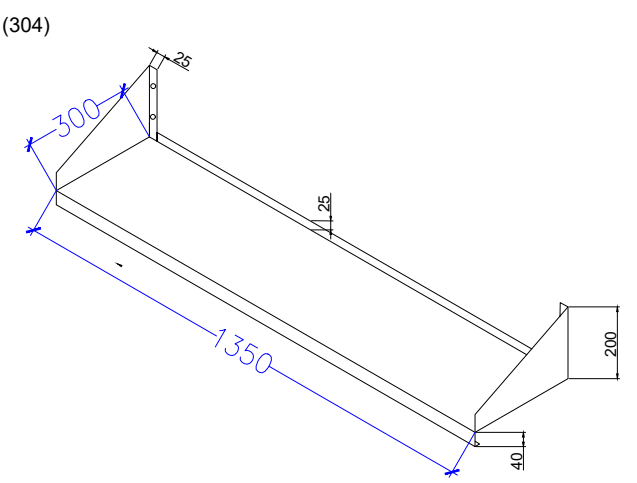

OVERHEAD SHELF

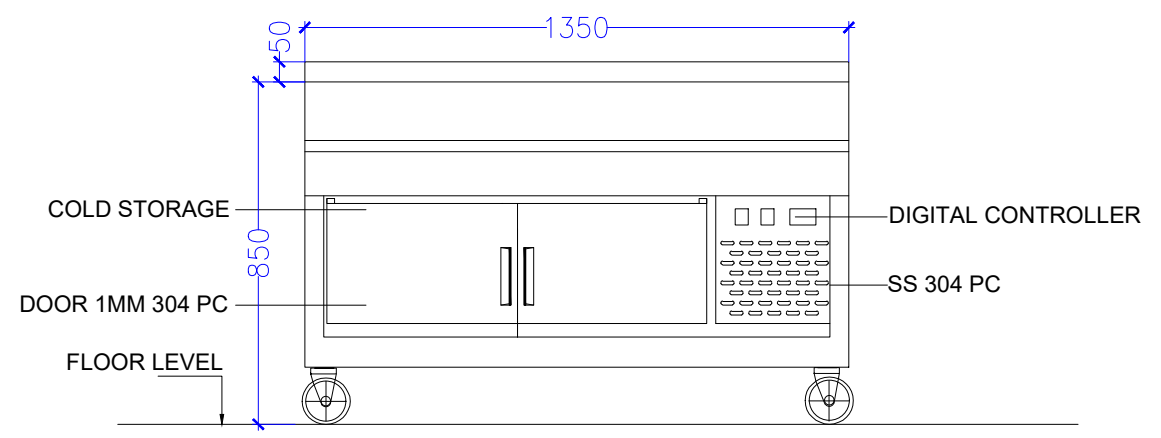

ELEVATION A-A

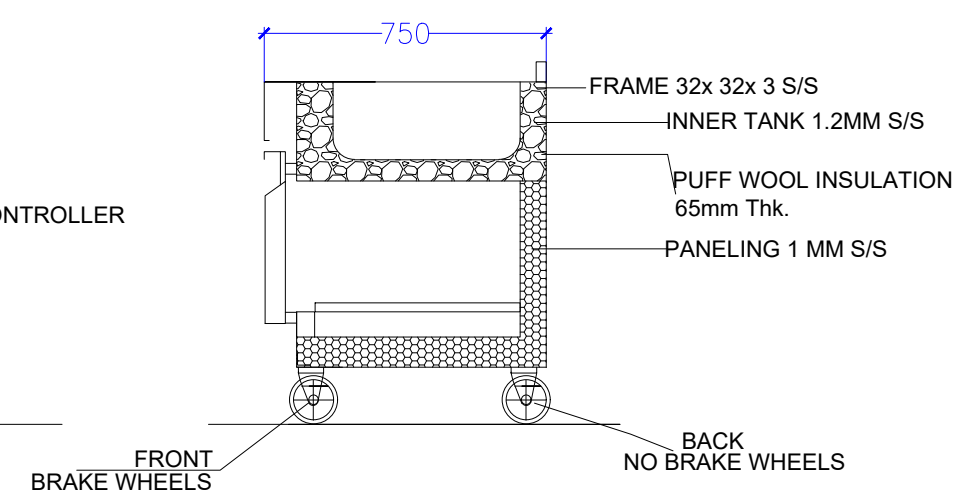

SECTION AT B-B

TRAVEL FOOD SERVICES

STATUS OF RELEASE: <input type="checkbox"/> FOR APPROVAL <input type="checkbox"/> FOR TENDER <input checked="" type="checkbox"/> FOR DISCUSSION <input type="checkbox"/> FOR CONSTRUCTION						STAMP:		DRAWING TITLE: KARIM'S & NOODLE WOK KITCHEN				
PROJECT NAME: UNA FOOD COURT						PROJECT NAME: UNA FOOD COURT		DRAWING TITLE: KARIM'S & NOODLE WOK EQUIPMENT DETAIL				
CLIENT NAME:						CLIENT NAME:		NORTH	DRAWING NO		Rev.	
ARCHITECT: TFS						ARCHITECT: TFS		SCALE	DATE 29-07-2023	PREP NIROJ SHRIWAL	CHKD NIROJ SHRIWAL	APPVD RITUPARN SHARMA

EQUIPMENT NO: KN-23
 EQUIPMENT NAME:
 MICROWAVE
 SIZE-: AS/SEL.
 QTY-: 01
 BRAND: CELFROST



EQUIPMENT NO: KN-24
 EQUIPMENT NAME: MIXER
 GRINDER
 SIZE-: AS/SEL.
 QTY-: 01
 BRAND: SUJATA MAKE

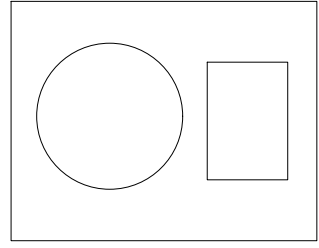

TRAVEL FOOD SERVICES

STATUS OF RELEASE:					
<input type="checkbox"/>	FOR APPROVAL	<input type="checkbox"/>	FOR TENDER		
<input checked="" type="checkbox"/>	FOR DISCUSSION	<input type="checkbox"/>	FOR CONSTRUCTION		
REV.	DATE	PREP BY	CHK BY	APPVD BY	REMARK

STAMP:
 PROJECT NAME:
UNA FOOD COURT
 CLIENT NAME:
 ARCHITECT:
TFS

DRAWING TITLE: KARIM'S & NOODLE WOK KITCHEN				
DRAWING TITLE: KARIM'S & NOODLE WOK EQUIPMENT DETAIL				
NORTH	DRAWING NO			Rev.
SCALE	DATE	PREP	CHKD	APPVD
	29-07-2023	NIROJ SHRIWAL	NIROJ SHRIWAL	RITUPARN SHARMA

EQUIPMENT NO: KN-25
 EQUIPMENT NAME: SS Storage Rack
 SIZE-: 900WX450DX1800HT.
 QTY-: 03
 BRAND: AS/SS
 MANUFACTURER SPEC.

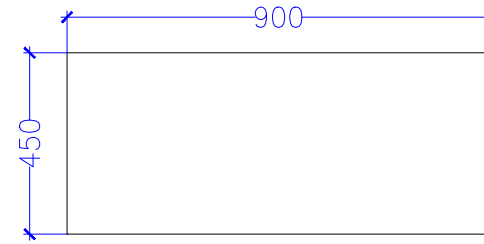

PLAN

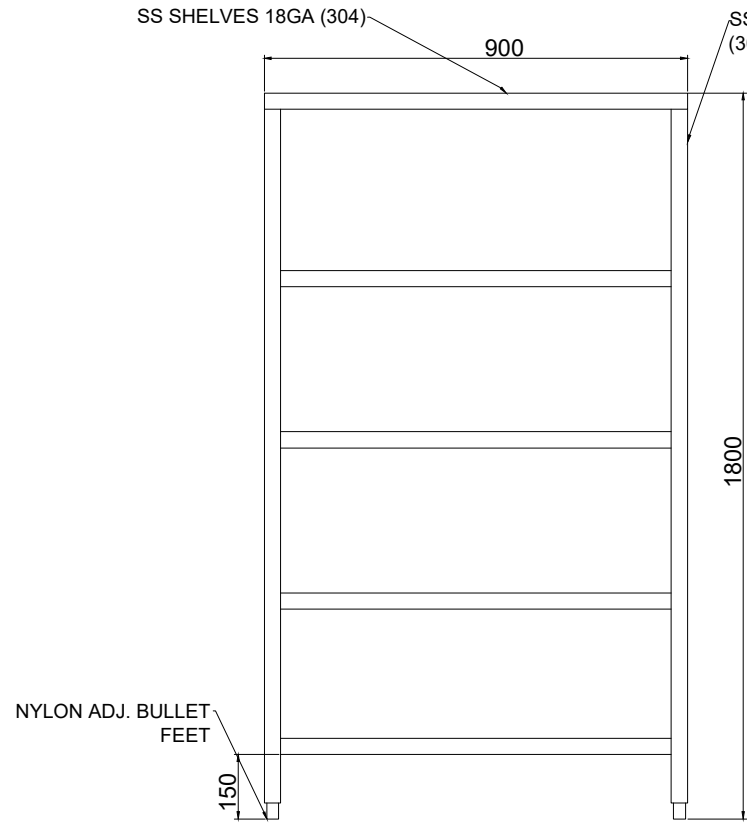

ELEVATION

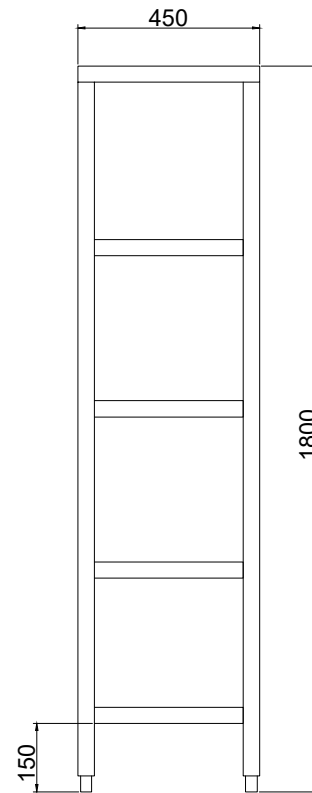

SECTION

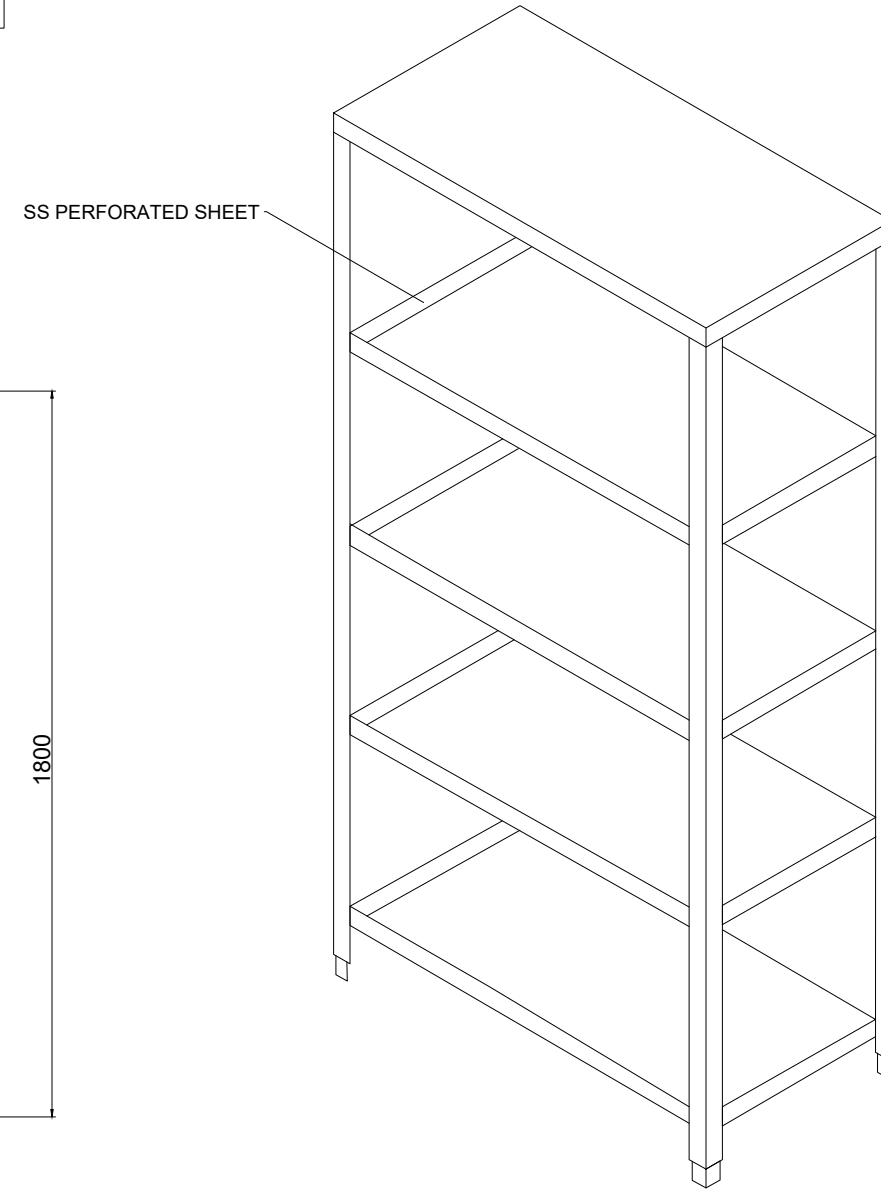

TRAVEL FOOD SERVICES

STATUS OF RELEASE:					
<input type="checkbox"/>	FOR APPROVAL	<input type="checkbox"/>	FOR TENDER		
<input checked="" type="checkbox"/>	FOR DISCUSSION	<input type="checkbox"/>	FOR CONSTRUCTION		
REV.	DATE	PREP BY	CHK BY	APPVD BY	REMARK

STAMP:	
PROJECT NAME:	UNA FOOD COURT
CLIENT NAME:	
ARCHITECT:	TFS

DRAWING TITLE:				
KARIM'S & NOODLE WOK KITCHEN				
DRAWING TITLE:				
KARIM'S & NOODLE WOK EQUIPMENT DETAIL				
NORTH	DRAWING NO			Rev.
SCALE	DATE	PREP	CHKD	APPVD
	29-07-2023	NIROJ SHRIWAL	NIROJ SHRIWAL	RITUPARN SHARMA

EQUIPMENT NO: KN-26

EQUIPMENT NAME: Pot Wash Rack with 5 Pipe type shelves

SIZE-: 900WX450DX1800HT.

QTY-: 02

BRAND: AS/SS

MANUFACTURER SPEC.

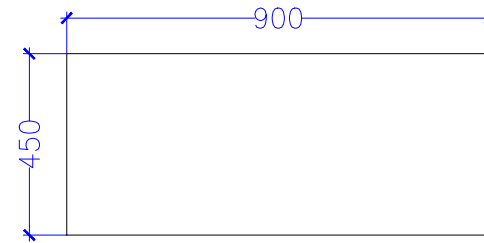

PLAN

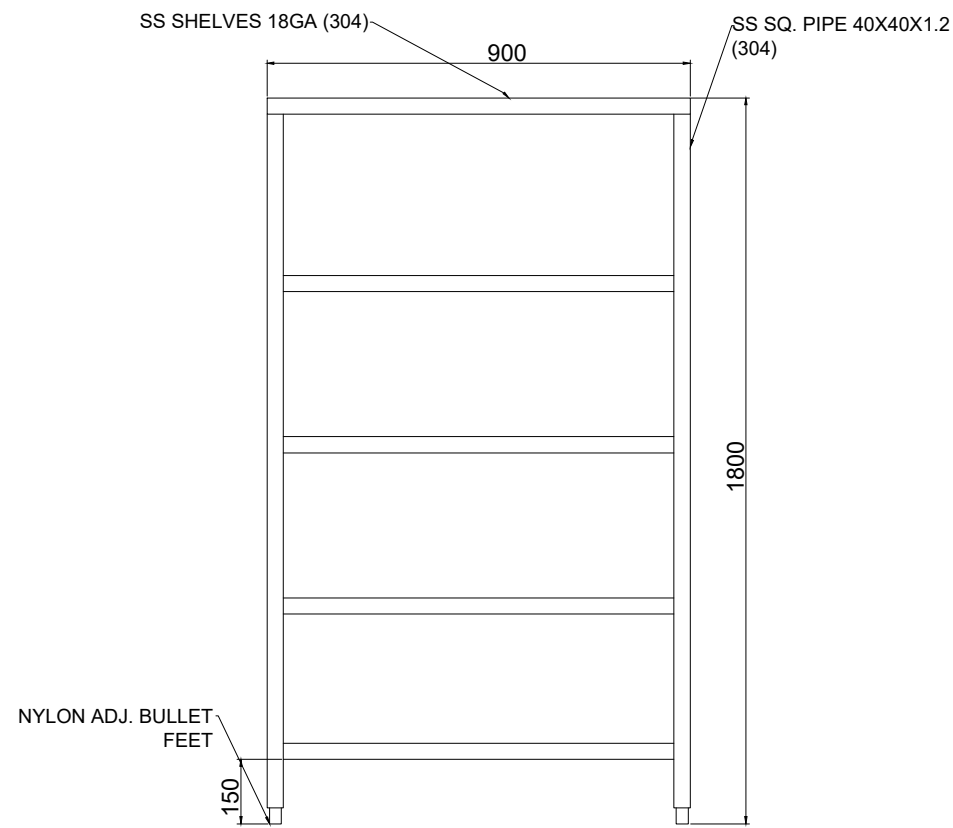

ELEVATION

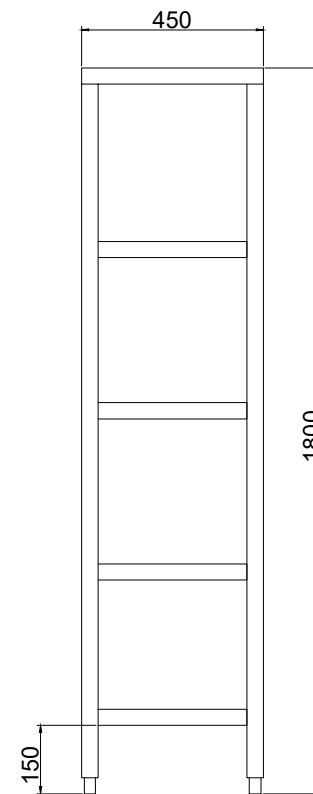

SECTION

SS PERFORATED SHEET

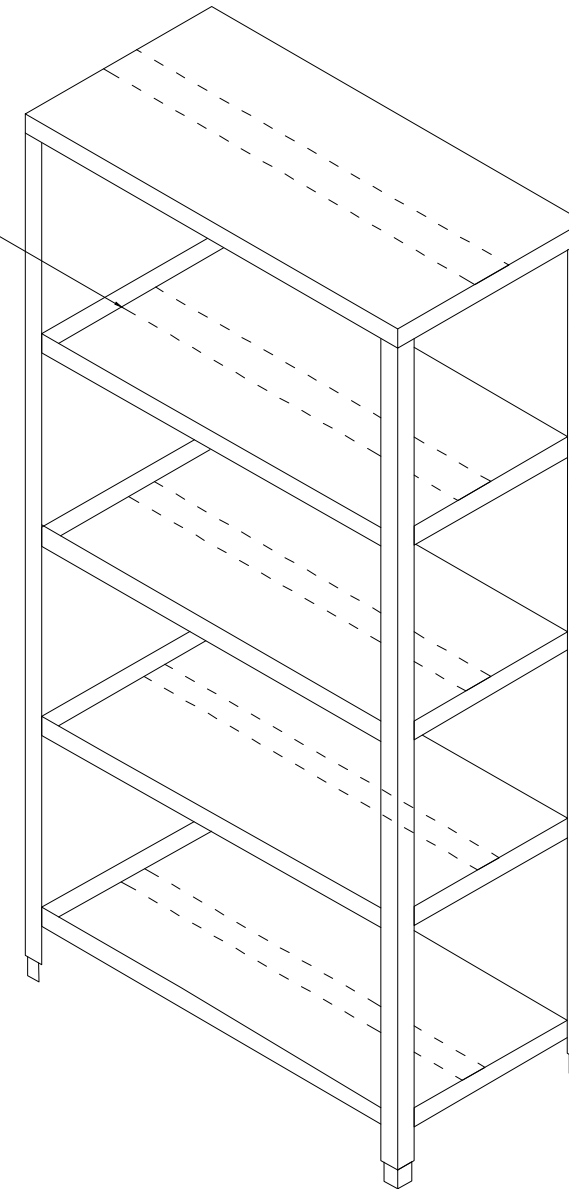

TRAVEL FOOD SERVICES

STATUS OF RELEASE:					
<input type="checkbox"/>	FOR APPROVAL	<input type="checkbox"/>	FOR TENDER		
<input checked="" type="checkbox"/>	FOR DISCUSSION	<input type="checkbox"/>	FOR CONSTRUCTION		
REV.	DATE	PREP BY	CHK BY	APPVD BY	REMARK

STAMP:	
PROJECT NAME:	UNA FOOD COURT
CLIENT NAME:	
ARCHITECT:	TFS

DRAWING TITLE:					KARIM'S & NOODLE WOK KITCHEN				
DRAWING TITLE:					KARIM'S & NOODLE WOK EQUIPMENT DETAIL				
NORTH		DRAWING NO			Rev.				
SCALE	DATE	PREP	CHKD	APPVD					
	29-07-2023	NIROJ SHRIWAL	NIROJ SHRIWAL	RITUPARN SHARMA					

EQUIPMENT NO: KN-27

EQUIPMENT NAME: Pot Wash Rack with 5 Perforated shelves

SIZE-: 900WX450DX1800HT.

QTY-: 02

BRAND: AS/SS

MANUFACTURER SPEC.

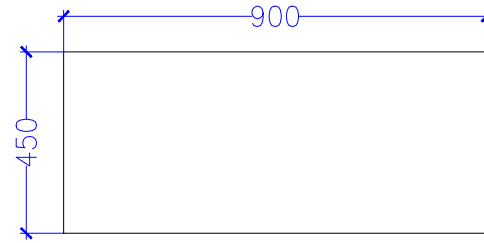

PLAN

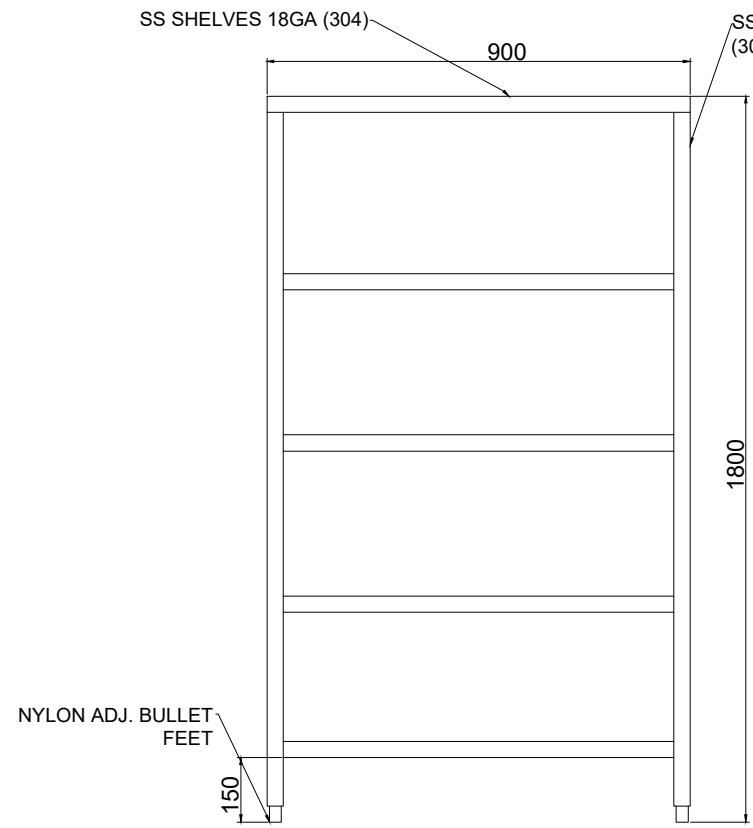

ELEVATION

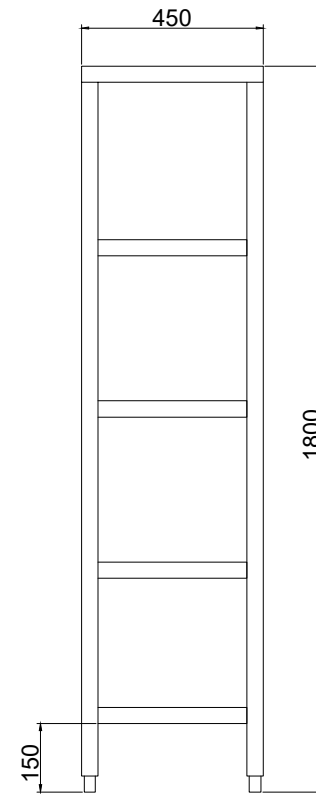

SECTION

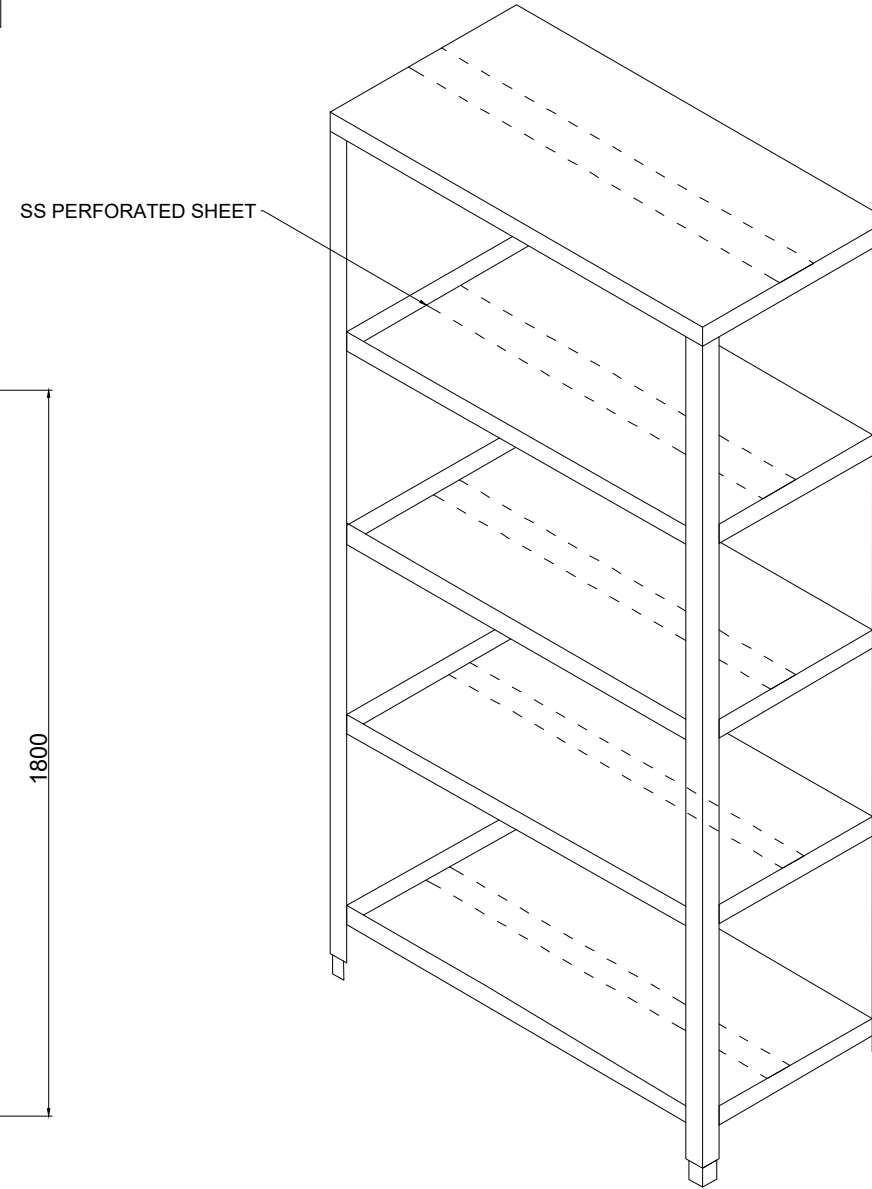

TRAVEL FOOD SERVICES

STATUS OF RELEASE:					
<input type="checkbox"/>	FOR APPROVAL	<input type="checkbox"/>	FOR TENDER		
<input checked="" type="checkbox"/>	FOR DISCUSSION	<input type="checkbox"/>	FOR CONSTRUCTION		
REV.	DATE	PREP BY	CHK BY	APPVD BY	REMARK

STAMP:	
PROJECT NAME:	UNA FOOD COURT
CLIENT NAME:	
ARCHITECT:	TFS

DRAWING TITLE:				
KARIM'S & NOODLE WOK KITCHEN				
DRAWING TITLE:				
KARIM'S & NOODLE WOK EQUIPMENT DETAIL				
NORTH	DRAWING NO			Rev.
SCALE	DATE	PREP	CHKD	APPVD
	29-07-2023	NIROJ SHRIWAL	NIROJ SHRIWAL	RITUPARN SHARMA

EQUIPMENT NO: KN- 28 & 28A

EQUIPMENT NAME: 3 Bowl Sink for Dishwash with overhead shelf & below OTG

SIZE-: 1500WX700DX850HT.
QTY-: 01

BRAND: AS/SS
MANUFACTURER SPEC.

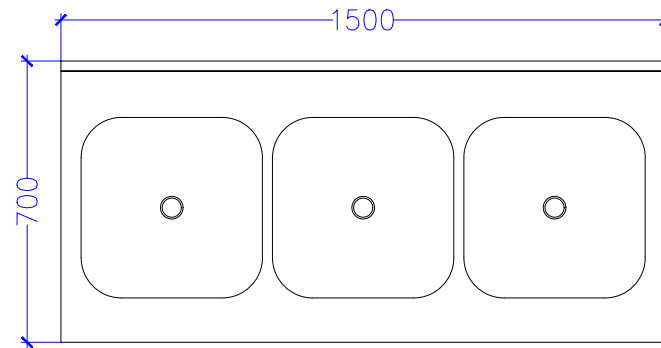

PLAN

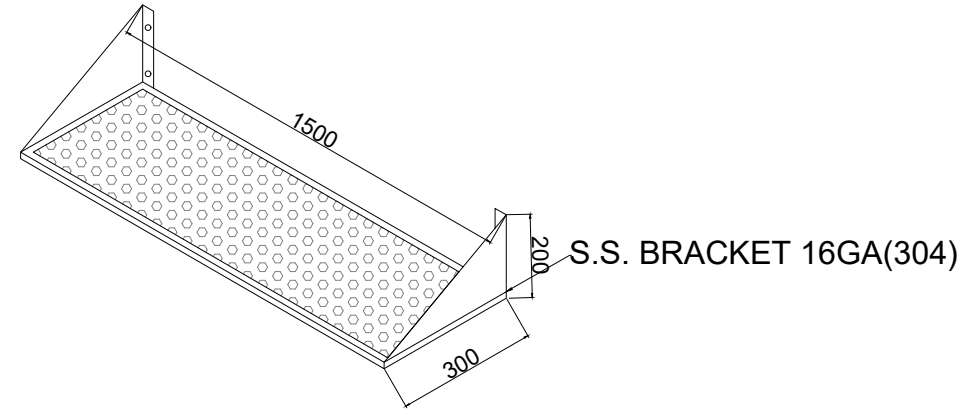

OVERHEAD SHELF

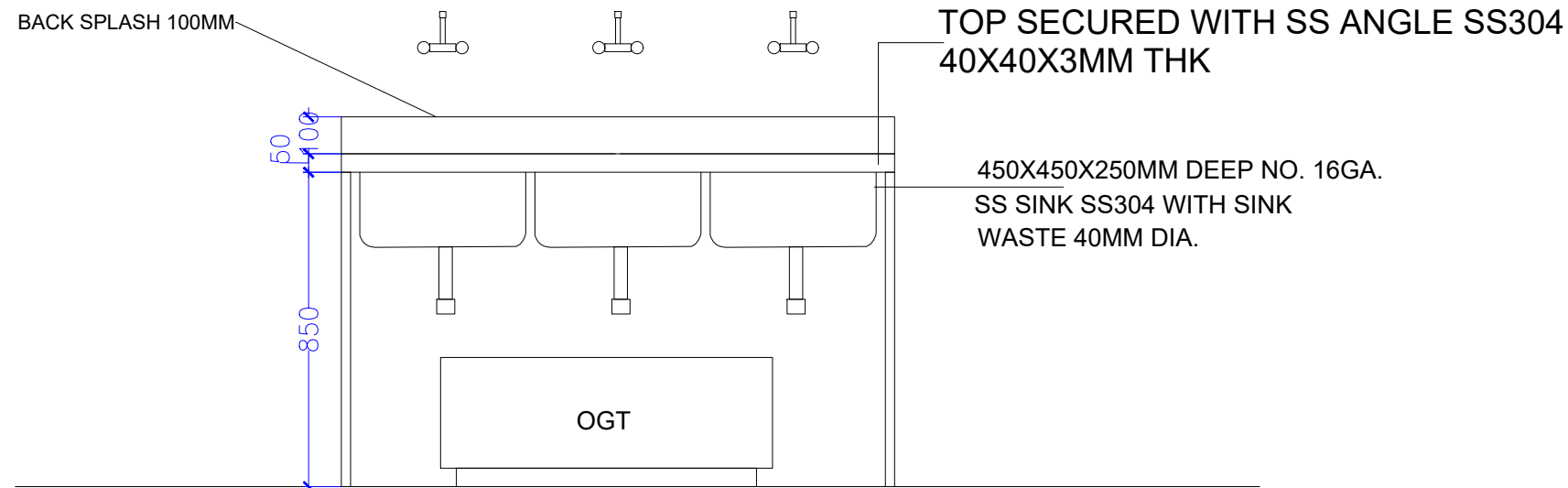

ELEVATION A

TRAVEL FOOD SERVICES

STATUS OF RELEASE:					
<input type="checkbox"/>	FOR APPROVAL	<input type="checkbox"/>	FOR TENDER		
<input checked="" type="checkbox"/>	FOR DISCUSSION	<input type="checkbox"/>	FOR CONSTRUCTION		
REV.	DATE	PREP BY	CHK BY	APPVD BY	REMARK

STAMP:	
PROJECT NAME:	UNA FOOD COURT
CLIENT NAME:	
ARCHITECT:	TFS

DRAWING TITLE:				
KARIM'S & NOODLE WOK KITCHEN				
DRAWING TITLE:				
KARIM'S & NOODLE WOK EQUIPMENT DETAIL				
NORTH	DRAWING NO			Rev.
SCALE	DATE	PREP	CHKD	APPVD
	29-07-2023	NIROJ SHRIWAL	NIROJ SHRIWAL	RITUPARN SHARMA

EQUIPMENT NO: KN-29 & 29A

EQUIPMENT NAME: Dirty Dish Landing & Overhead Shelf

SIZE: 1200WX700DX850HT.

BRAND: AS/SS
 MANUFACTURER SPEC.
 QTY-: 01

TOP MADE OF 16G SS304 SS SHEET
 SPLASH OF REAR SIDES 50MM HIGH

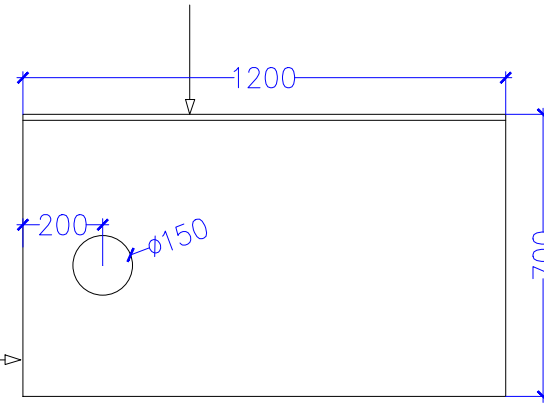

PLAN

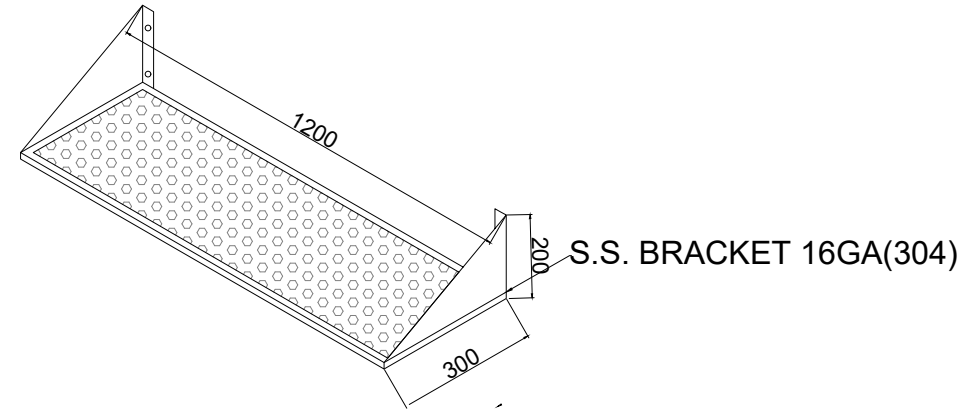

OVERHEAD SHELF

TOP SECURED WITH SS ANGLE SS304
 40X40X3MM THK

BACK SPLASH 100MM

TOP SECURED WITH SS ANGLE SS304
 40X40X3MM THK

S.S. COVERING 20GA.(304)

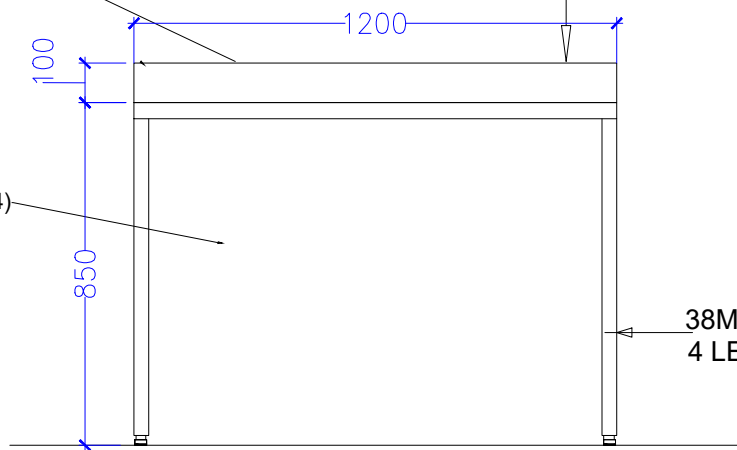

ELEVATION A

38MM SQ. PIPE SS304
 4 LEGS WITH ADJ. FEET

TRAVEL FOOD SERVICES

STATUS OF RELEASE:					
<input type="checkbox"/>	FOR APPROVAL	<input type="checkbox"/>	FOR TENDER		
<input checked="" type="checkbox"/>	FOR DISCUSSION	<input type="checkbox"/>	FOR CONSTRUCTION		
REV.	DATE	PREP BY	CHK BY	APPVD BY	REMARK

STAMP:	
PROJECT NAME:	UNA FOOD COURT
CLIENT NAME:	
ARCHITECT:	TFS

DRAWING TITLE:				
KARIM'S & NOODLE WOK KITCHEN				
DRAWING TITLE:				
KARIM'S & NOODLE WOK EQUIPMENT DETAIL				
NORTH	DRAWING NO			Rev.
SCALE	DATE	PREP	CHKD	APPVD
	29-07-2023	NIROJ SHRIWAL	NIROJ SHRIWAL	RITUPARN SHARMA

EQUIPMENT NO: KN-30
 EQUIPMENT NAME: SS
 DUSTBIN
 SIZE-: 450WX450DX750HT.
 QTY-: 01
 BRAND: AS/SS
 MANUFACTURER SPEC.

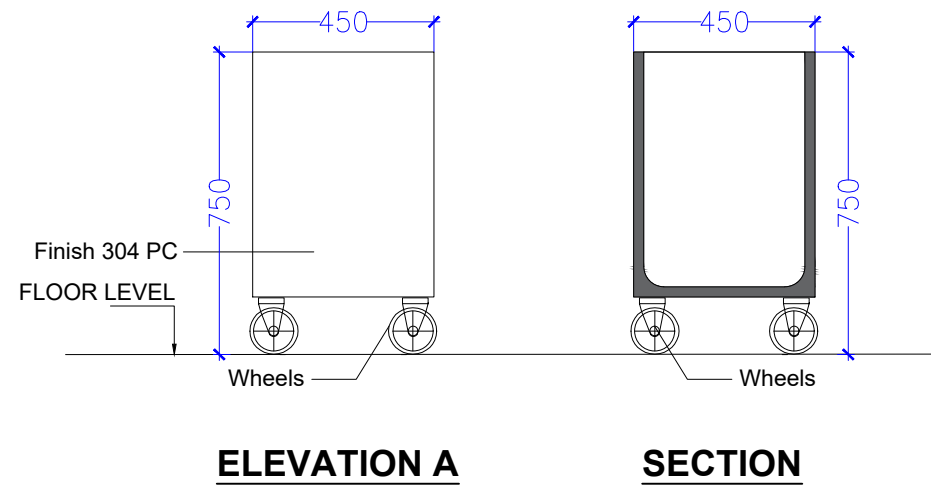
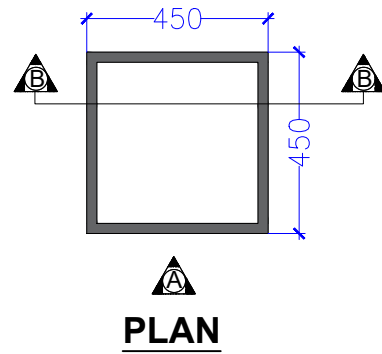

TRAVEL FOOD SERVICES

STATUS OF RELEASE:					
<input type="checkbox"/>	FOR APPROVAL	<input type="checkbox"/>	FOR TENDER		
<input checked="" type="checkbox"/>	FOR DISCUSSION	<input type="checkbox"/>	FOR CONSTRUCTION		
REV.	DATE	PREP BY	CHK BY	APPVD BY	REMARK

STAMP:	
PROJECT NAME:	UNA FOOD COURT
CLIENT NAME:	
ARCHITECT:	TFS

DRAWING TITLE:				
KARIM'S & NOODLE WOK KITCHEN				
DRAWING TITLE:				
KARIM'S & NOODLE WOK EQUIPMENT DETAIL				
NORTH	DRAWING NO			Rev.
SCALE	DATE	PREP	CHKD	APPVD
	29-07-2023	NIROJ SHRIWAL	NIROJ SHRIWAL	RITUPARN SHARMA

EQUIPMENT NO: KN-31

EQUIPMENT NAME:
Handwash Sink

SIZE-: 600WX600DX850HT.

QTY-: 01

BRAND: AS/SS
MANUFACTURER SPEC.

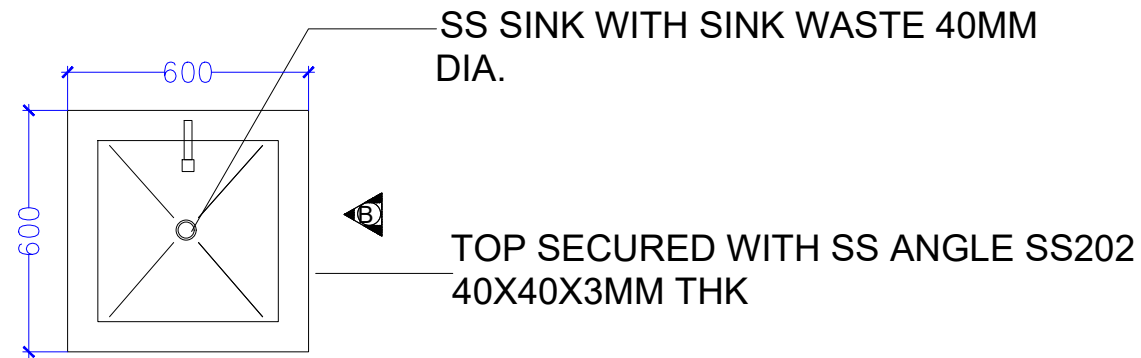

PLAN

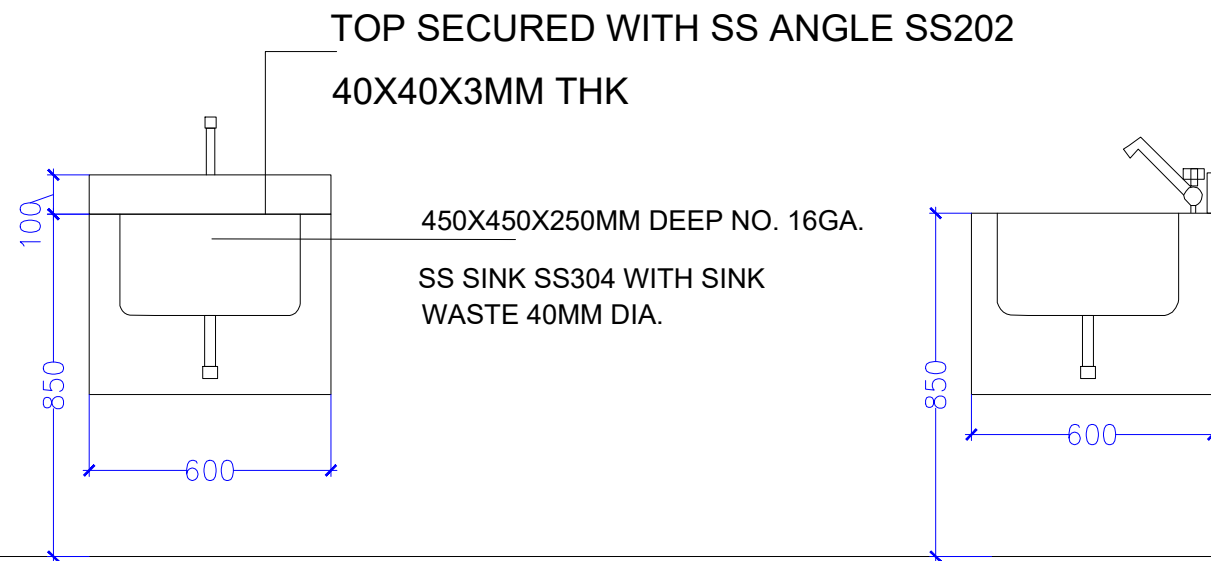

ELEVATION A

ELEVATION B

TRAVEL FOOD SERVICES

STATUS OF RELEASE:					
<input type="checkbox"/>	FOR APPROVAL	<input type="checkbox"/>	FOR TENDER		
<input checked="" type="checkbox"/>	FOR DISCUSSION	<input type="checkbox"/>	FOR CONSTRUCTION		
REV.	DATE	PREP BY	CHK BY	APPVD BY	REMARK

STAMP:	
PROJECT NAME:	UNA FOOD COURT
CLIENT NAME:	
ARCHITECT:	TFS

DRAWING TITLE:				
KARIM'S & NOODLE WOK KITCHEN				
DRAWING TITLE:				
KARIM'S & NOODLE WOK EQUIPMENT DETAIL				
NORTH	DRAWING NO			Rev.
SCALE	DATE	PREP	CHKD	APPVD
	29-07-2023	NIROJ SHRIWAL	NIROJ SHRIWAL	RITUPARN SHARMA

EQUIPMENT NO: KN-32

EQUIPMENT NAME: Potato Bin

SIZE-: 450WX450DX850HT.

QTY-: 01

BRAND: AS/SS
MANUFACTURER SPEC.

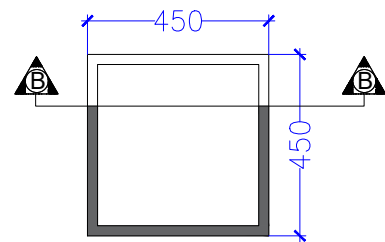

PLAN

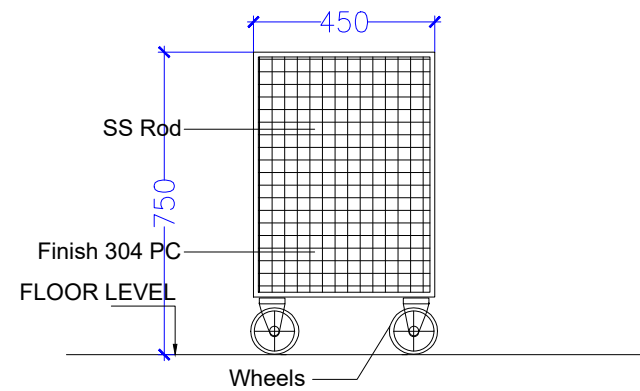

ELEVATION A

EQUIPMENT NO: KN-34

EQUIPMENT NAME: Weighing Machine

SIZE-: AS/SPEC.

QTY-: 01

BRAND: METIS

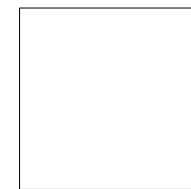

PLAN

EQUIPMENT NO: KN-35 & KN-36

EQUIPMENT NAME: Aata Bin & Maida Bin

SIZE-: 700WX300DX700HT.

QTY-: 02

BRAND: AS/SELECTION

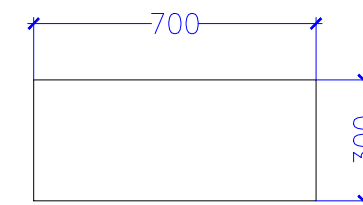

PLAN

TRAVEL FOOD SERVICES

STATUS OF RELEASE:					
<input type="checkbox"/>	FOR APPROVAL	<input type="checkbox"/>	FOR TENDER		
<input checked="" type="checkbox"/>	FOR DISCUSSION	<input type="checkbox"/>	FOR CONSTRUCTION		
REV.	DATE	PREP BY	CHK BY	APPVD BY	REMARK

STAMP:	
PROJECT NAME:	UNA FOOD COURT
CLIENT NAME:	
ARCHITECT:	TFS

DRAWING TITLE:				
KARIM'S & NOODLE WOK KITCHEN				
DRAWING TITLE:				
KARIM'S & NOODLE WOK EQUIPMENT DETAIL				
NORTH	DRAWING NO			Rev.
SCALE	DATE	PREP	CHKD	APPVD
	29-07-2023	NIROJ SHRIWAL	NIROJ SHRIWAL	RITUPARN SHARMA