

#GRUB HUB@UNA

S. No.	Equipment	Dimensions	Qty	Category	Wattage	Total Wattage	Elec. Point Ht.	WS Height	Drain	Gas & GLDS Point	Exhaust	Remarks
GIANI'S												
GI-02	CHEST FREEZER FOR KULFI	MODEL-CF3-125DSW	1	Refrigeration	0.5KW	0.5KW	1200MM					BLUESTAR
GI-03	DEEP FREEZER 1000LTR.	MODEL-CHFSD100DHSW	1	Refrigeration	0.5KW	0.5KW	1200mm					
GI-04	ICE CREAM CHEST FREEZER	MODEL-EKG650G	1	Refrigeration	0.5KW	0.5KW	300MM					ELANPRO
GI-05	Weighting Scale 2Kg (Counter	SM-500	1	Boughtout								SMART SCALE
GI-06	BLENDER WITH SOUND ENCLOSURE	JTC TM 800AQ	1	Boughtout	1.5KW	1.5KW	1200mm					OMNI BLEND V
GI-07	WAFFLE CONE MACHINE	320Wx250Dx178H	1	Boughtout	1.5KW	1.5KW	1200mm					CB - 01F
GI-08	MELTER (CHOCOLATE WARMER)		1	Boughtout	1.5KW	1.5KW	1200mm					TEM-2TC
GI-09	SS SINK TO BE FIXED IN CORIAN COUNTER	450Wx700Dx900H	1	Fabrication								
GI-10	SS FLUDA COUNTER REF.	700Wx700Dx850H	1		0.5KW	0.5KW	1200mm					
GI-11	SS SINK TO BE FIXED IN CORIAN COUNTER	450Wx450Dx850H	1	Fabrication								
BROUGHT OUT ITEMS:												
1	DRAIN THROUGH GRATING	300x300	2	Fabrication								
2	GREASE TRAP	450Wx400Dx300H	1	Fabrication								
3	MIXER FOR SINK	AS/SELECTION	2	Boughtout								
TOTAL ELECTRIC LOAD												6.5KW
NOTE:												
<ol style="list-style-type: none"> All the dimension needs to be physically measured at site by the vendor before commencing the production.. G/N Pan Requirement will be shared by concerned brand. 												

EQUIPMENT NO: GI-02

EQUIPMENT NAME: Deep Freezer for Kulfi

SIZE-: 600WX700DX850HT.

QTY-: 01

BRAND:BLUESTAR

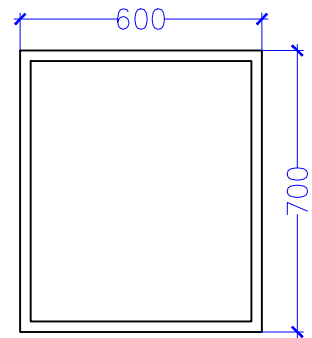

EQUIPMENT NO: GI-03

EQUIPMENT NAME: Deep Freezer 1000LTR.

SIZE-: 1500WX700DX850HT.

QTY-: 01

BRAND:BLUESTAR

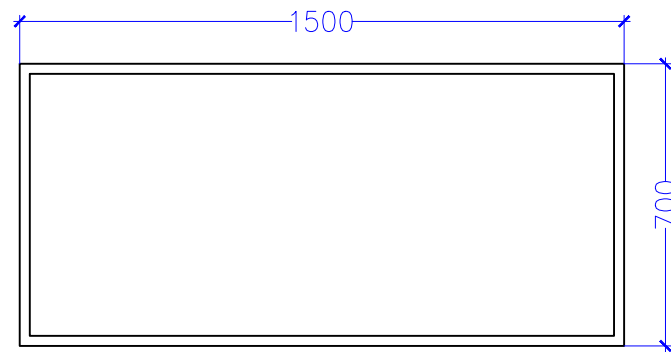

EQUIPMENT NO: GI-04

EQUIPMENT NAME: Ice - Cream Unit

SIZE-: 1800WX700DX850HT.

QTY-: 01

BRAND:ELANPRO



GIANI'S

TRAVEL FOOD SERVICES

STATUS OF RELEASE:

- FOR APPROVAL
- FOR DISCUSSION
- FOR TENDER
- FOR CONSTRUCTION

REV.	DATE	PREP BY	CHK BY	APPVD BY	REMARK

STAMP:

PROJECT NAME:

UNA FOOD COURT

CLIENT NAME:

ARCHITECT:

TFS

DRAWING TITLE:

GIANI'S KITCHEN

DRAWING TITLE:

GIANI'S EQUIPMENT DETAIL

NORTH		DRAWING NO			Rev.
SCALE	DATE	PREP	CHKD	APPVD	
	15-12-2023	NIROJ SHRIWAL	NIROJ SHRIWAL	RITUPARN SHARMA	

EQUIPMENT NO: GI-05
 EQUIPMENT NAME: Weighing Machine (2kg.)
 SIZE-: AS/SEL.
 QTY-: 01
 BRAND:METIS

EQUIPMENT NO: GI-06
 EQUIPMENT NAME: Blender
 SIZE-: AS/SEL.
 QTY-: 01
 BRAND:JTC

EQUIPMENT NO: GI-07
 EQUIPMENT NAME: Waffle Cone
 SIZE-: AS/SEL.
 QTY-: 01
 BRAND:AS/SEL.

EQUIPMENT NO: GI-08
 EQUIPMENT NAME: Melter Hot Choco
 SIZE-: AS/SEL.
 QTY-: 01
 BRAND:AS/SEL.

EQUIPMENT NO: GI-12
 EQUIPMENT NAME: SS Round Shape Dustbin
 SIZE-: AS/SEL.
 QTY-: 01
 BRAND:AS/SEL.

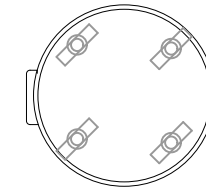
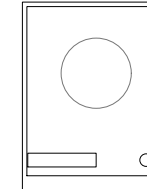
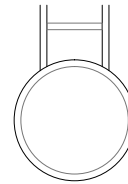
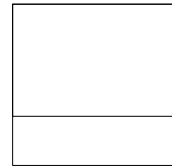

GIANI'S

TRAVEL FOOD SERVICES

STATUS OF RELEASE:					
<input type="checkbox"/>	FOR APPROVAL	<input type="checkbox"/>	FOR TENDER		
<input checked="" type="checkbox"/>	FOR DISCUSSION	<input type="checkbox"/>	FOR CONSTRUCTION		
REV.	DATE	PREP BY	CHK BY	APPVD BY	REMARK

STAMP:	
PROJECT NAME:	UNA FOOD COURT
CLIENT NAME:	
ARCHITECT:	TFS

DRAWING TITLE:				
GIANI'S KITCHEN				
DRAWING TITLE:				
GIANI'S EQUIPMENT DETAIL				
NORTH	DRAWING NO			Rev.
SCALE	DATE	PREP	CHKD	APPVD
	15-12-2023	NIROJ SHRIWAL	NIROJ SHRIWAL	RITUPARN SHARMA

EQUIPMENT NO: GI-09 & GI-11
 EQUIPMENT NAME: SS Handwash to be fixed in Corian counter
 SIZE-: 450WX450D
 QTY-: 02
 BRAND:SS Manufacturer

EQUIPMENT NO: GI-10
 EQUIPMENT NAME: Fluda Counter
 SIZE-: 700WX700D
 QTY-: 01
 BRAND:SS Manufacturer

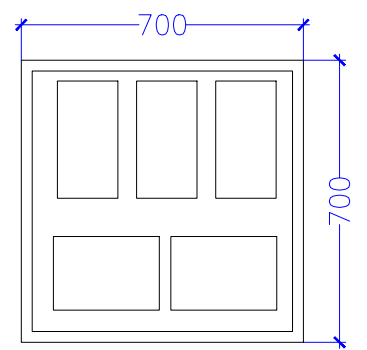
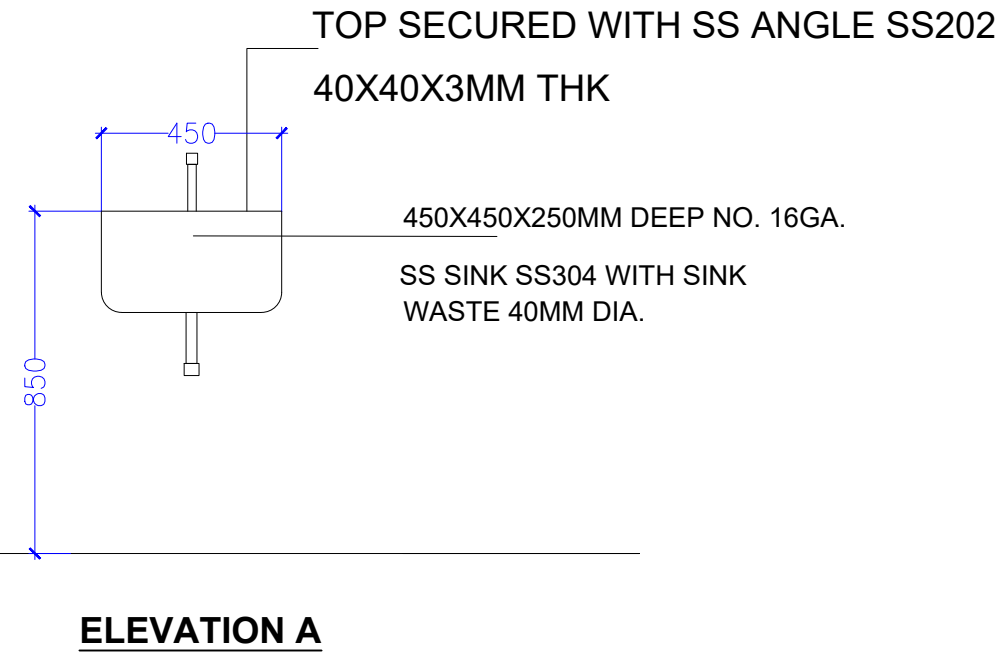
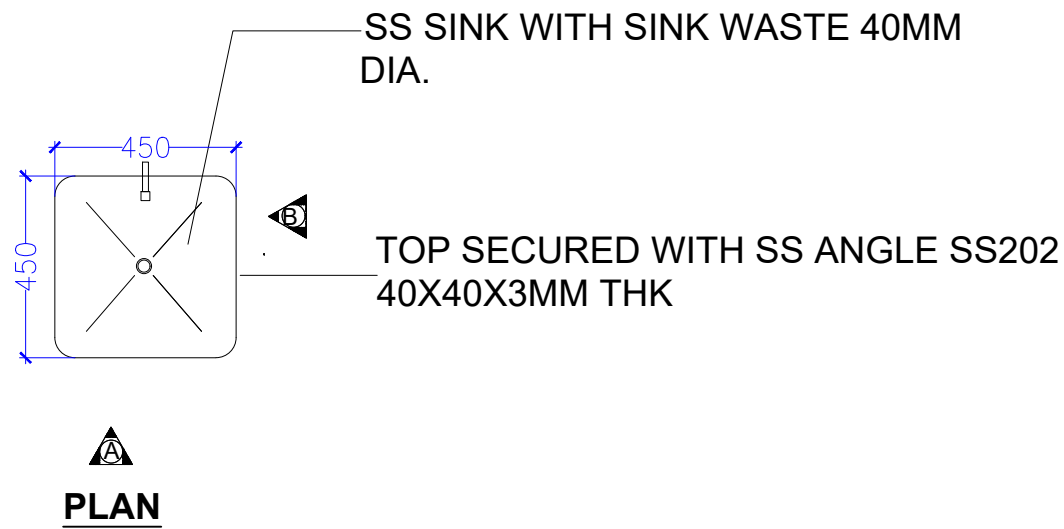

GIANI'S

TRAVEL FOOD SERVICES

STATUS OF RELEASE:						STAMP:		DRAWING TITLE: GIANI'S KITCHEN									
<input type="checkbox"/> FOR APPROVAL		<input type="checkbox"/> FOR TENDER				PROJECT NAME: UNA FOOD COURT		DRAWING TITLE: GIANI'S EQUIPMENT DETAIL									
<input checked="" type="checkbox"/> FOR DISCUSSION		<input type="checkbox"/> FOR CONSTRUCTION						CLIENT NAME:		NORTH		DRAWING NO		Rev.			
REV.						ARCHITECT: TFS		SCALE		DATE		PREP		CHKD		APPVD	
										15-12-2023		NIROJ SHRIWAL		NIROJ SHRIWAL		RITUPARN SHARMA	