

ALL DIMENSIONS ARE IN MM.

PROJECT NAME - BIRYANI BHAI - LUCKNOW STREET

ITEM NAME Counter sunk Sink

ITEM NO. MK-08

SECTION

DIMENSION - 450 x 450 x 200

SPECIFICATION FOR : - Counter sunk sink

* TOP 16 GAUGE 304 GRADE S.S TO USE

TOP VIEW

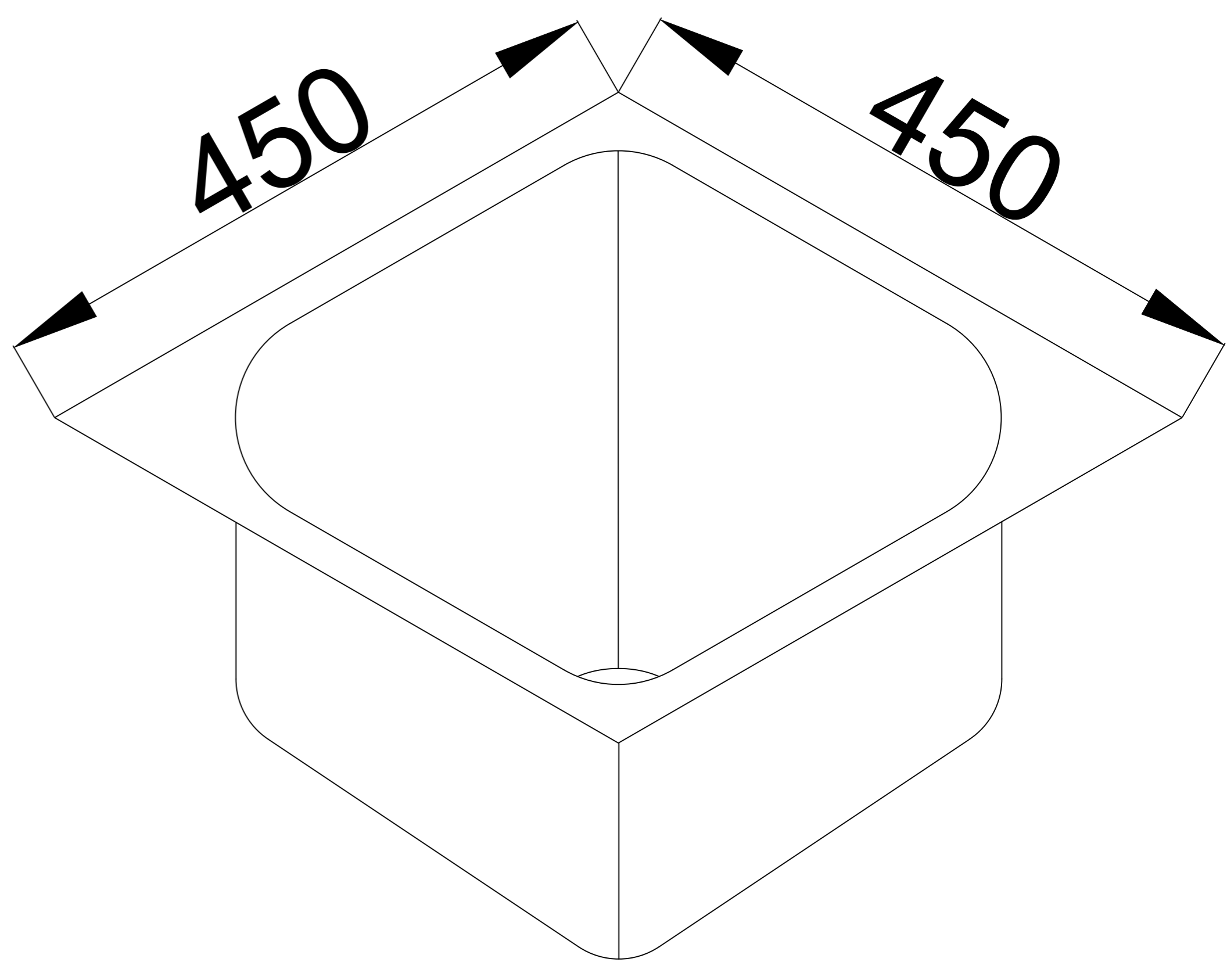
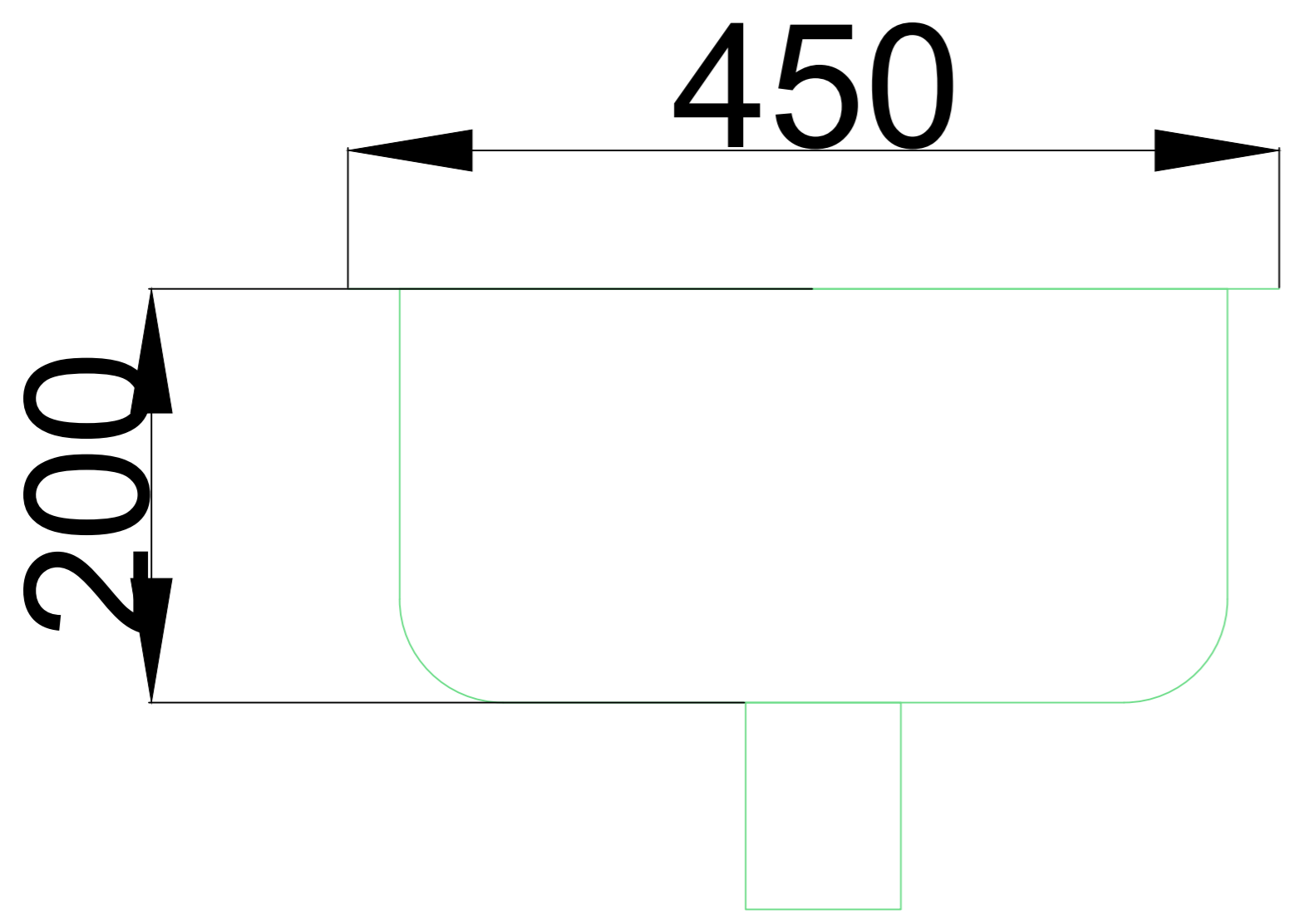
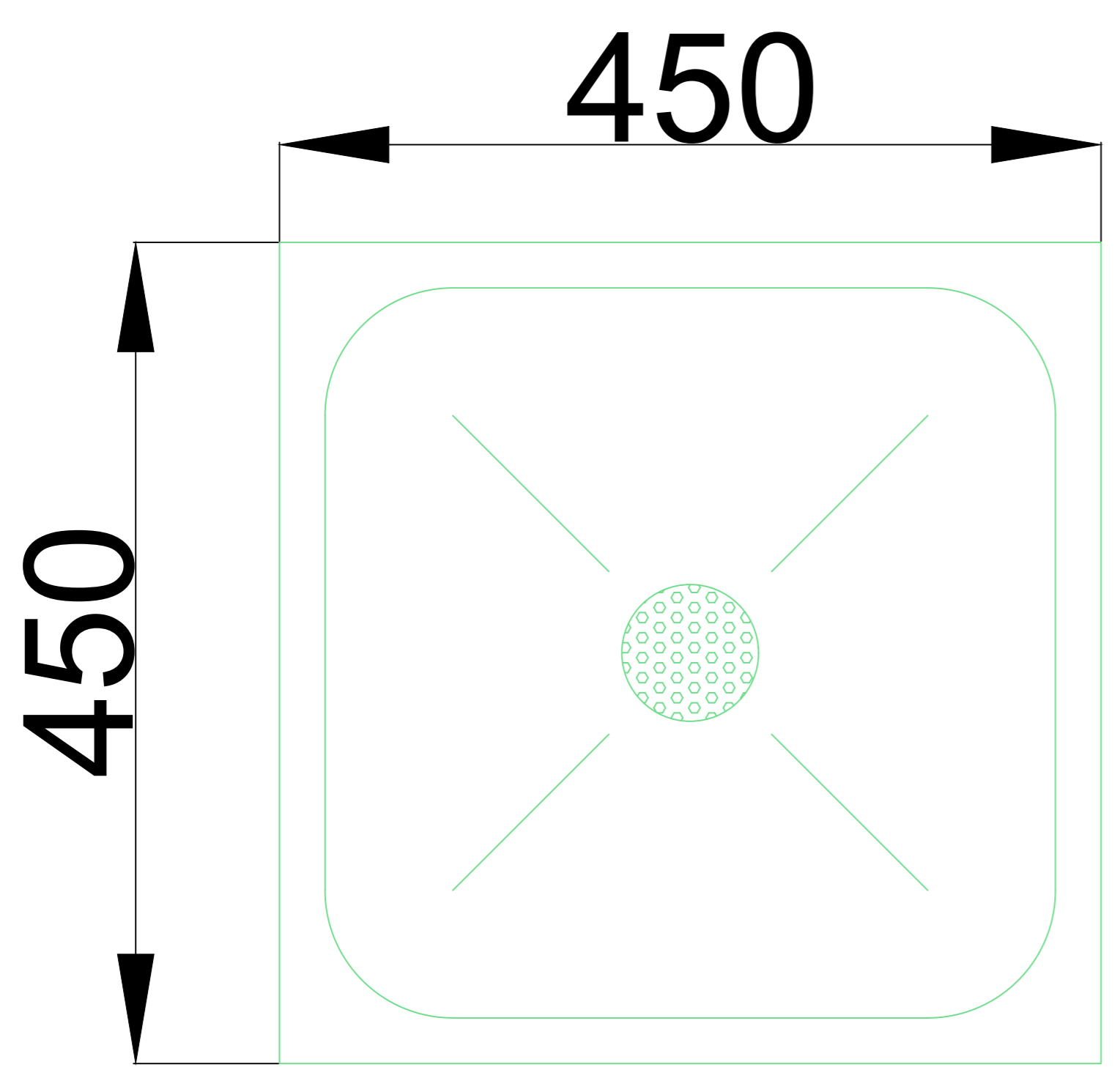

IMPORTANT

- INDICATIVE DRAWING
- FINAL SHOP DRAWING TO BE PROVIDED BY FABRICATOR AFTER CHECK AT SITE FOR APPROVAL BY CONSULTANT
- ONLY STAMPED & SIGNED SHOP DRAWINGS TO BE USED FOR FINAL FABRICATION.

All Design & Drawing are the Property of IHP Design and Not to be Used Copied or Reproduced Without Prior Written Permission.