



Travel Food Services

TRAVEL FOOD SERVICES

Shiv Sagar Estate, A Block, 1st Floor, Dr
Annie Besant Rd, Worli, Mumbai,
Maharashtra 400018

TITLE

CURRY
KITCHEN

PROJECT

FRENCH LOAF
CHENNAI

CURRY KITCHEN LAYOUT
AT FRENCH LOAF CHENNAI
EQUIPMENT SCHEDULE

DATE

17-Aug-24

SR.No.	Eq.No.	DESCRIPTION	MODEL NO	DIMENSIONS(L x W x HT)	QTY	ELECTRIC SUPPLY	Per Kw	TOTAL KW	AMPS	TYPE OF SWITCH
						1HP/3HP				
1	CK-01	POS	IT	STD	1	1PH	1.00	1.0	5 / 15 Amp	Switch Socket
2	CK-02	MARKETING SCREEN	MARKETING	STD	1					
3	CK-03	JUICE DISPENSER	UGOLININ-DELUX 12/2	360 x 480 x 570Ht.	1	1PH	1.00	1.0	5 / 15 Amp	Switch Socket
4	CK-04	POS COUNTER STAIR TYPE IMPULSE DISPLAY PROVISION WITH STORAGE BELOW & SNEEZ GUARD ON COUNTER TOP	CARPENTRY WORK /AS PER ID	975 x 675 x 850Ht.	1					
5	CK-04a	SNEEZ GUARD WITH TUFFEN GLASS	CARPENTRY WORK /AS PER ID	2325 x 300 x 425Ht.	1					
6	CK-05	SS 2 CONTAINER HOT BAIN MARIE 1/1x150Deep GN PAN WITH EXTERNAL PANEL & REMOVABLE PATTI FOR ADJUSTABLE GN PAN	FABRICATED	750 x 650 x 850	1	1PH	3.00	3.0	32	Metal Clad
7	CK-06	SS 3 CONTAINER HOT BAIN MARIE 1/1x150Deep GN PAN WITH EXTERNAL PANEL & REMOVABLE PATTI FOR ADJUSTABLE GN PAN	FABRICATED	1075 x 650 x 850	1	1PH	3.00	3.0	32	Metal Clad
8	CK-07	SS COLD BAIN MARIE WITH 1 NO, GN PAN 1/1 x 150mm DEEP	FABRICATED	450 x 650 x 850	1	1PH	1.00	1.0	5 / 15 Amp	Switch Socket
9	CK-08	SIDE COUNTER WITH PROVISION STORAGE BELOW	CARPENTRY WORK AS PER INTEROR DESIGN	1500 x 650 x 850Ht.	1					
10	CK-09	TABLE TOP MOMOs STEAMER	SR-WA18H(SS)	256 x 256 x 360Ht.	2	1PH	1.50	3.0	5 / 15 Amp	Switch Socket
11	CK-10	TABLE TOP FOOD WARMER	MODEL NO:- MIR11	335 x 615 x 420	1	1PH	1.50	1.5	5 / 15 Amp	Switch Socket
12	CK-11	SS CIVIL COUNTER FITTED SINK	FABRICATED	400 x 400 x 150	1					
13	CK-12	GREASE TRAP	NUGREEN-NGT-14	337 x404 x 303	1					
14	CK-13	MICROWAVE OVEN WITH WALL MOUNTED STAND	CELFROST-CMO25	511 x 432 x 311	1	1PH	1.50	1.5	5 / 15 Amp	Switch Socket
15	CK-14	BACK COUNTER TOP WITH PROVISION OF SUNK IN SINK & BELOW STORAGE	CARPENTRY WORK /AS PER ID	3350 x 750 x 900 HIEGHT INSIDE CLEAR	1					
16	CK-15	TABLE TOP INDUCTION PLATE	STELLA-TS-3501	350 x 410 x 95	2	1PH	3.50	7.0	32	Metal Clad
17	CK-16	2 DOOR U/C CHILLER. WITH LOCKABLE CASTOR WHEELS (2 Nos.WITH BREAK INFRONT & 2 Nos. WITHOUT BREAK) & HEATING ELEMENT FOR DRAIN .	BLUE STAR-UC2100GC	1365 x 700 x 850	1	1PH	1.00	1.0	5 / 15 Amp	Switch Socket
18	CK-17	SPEED OVEN	MERRYCHEF-E1S	400 x 550 x 600	1	1PH	3.00	3.0	32	Metal Clad
19	CK-18	TEA & COFFE MAKER MACHINE- GEMINI	GEMINI	600 x 270 x 470Ht.	1	1PH	2.30	2.3	5 / 15 Amp	Switch Socket
20	CK-19	VISI COOLER	BLUESTAR-SC300F	576 x 686 x 1454Ht.	1	1PH	1.00	1.0	5 / 15 Amp	Switch Socket
Total Kw								29.3		
SOE										
1	SO-01	INSECT KILLERS	SOE		1	1PH	0.50	0.50	5 / 15 Amp	Switch Socket
2	SO-02	FIRE EXTINGUISHER ABC-4KG	SOE		1					
3	SO-03	FIRE EXTINGUISHER CO/2-4.5KG	SOE		1					
4	SO-04	FIRE EXTINGUISHER KTYPE - 6KG	SOE		1					
5	SO-05	FIRE BLANKET - 6' X 4'	SOE		1					
Total Kw-SOE								0.5		
Total Kw								29.8		

CURRY KITCHEN @ FRENCH LOAF - CHENNAI-19-08-24
DRY OUTLET



INHOUSE DESIGN

CURRY KITCHEN @ FRENCH LOAF CHENNAI

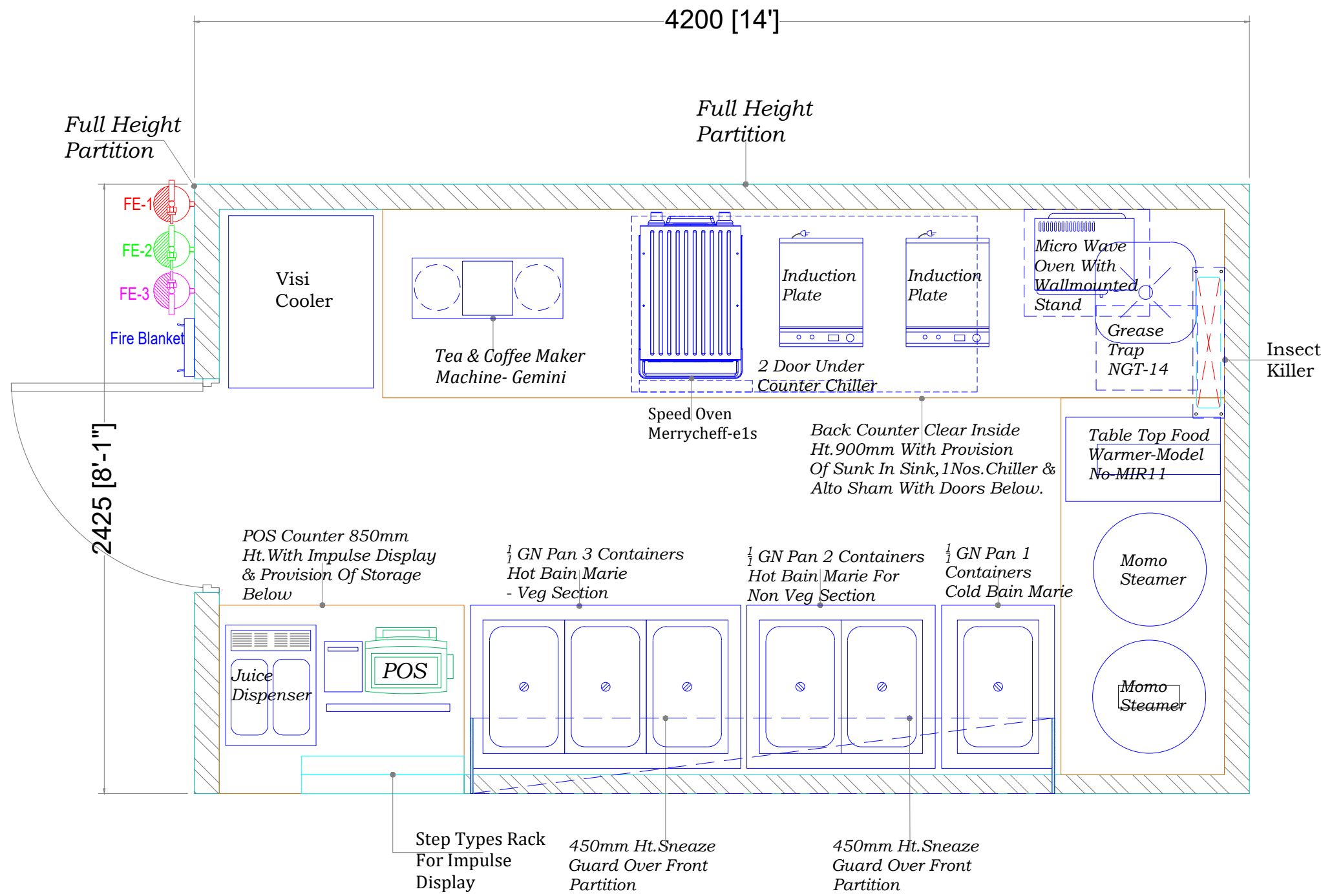

SYMBOL	DESCRIPTION	QTY.
FE-1	Fire Extinguisher ABC-4Kg	01 No.
FE-2	Fire Extinguisher CO ₂ -4.5Kg	01 No.
FE-3	Fire Extinguisher KType - 6Kg	01 No.
	Fire Blanket - 6' X 4'	01 No.

PROJECT	LOCATION	DRAWN BY	DATE	CHK BY	DATE	REVISION No.	FINAL APPROVED	DRAWING	DRAWING NAME	SHEET NUMBER
CURRY KITCHEN	FRENCH LOAF-CHENNAI	FAHEEM	19-08-2024						EQUIP NAMING LAYOUT	01 OF 03
		DWG.No.		SCALE			DATE			
		----		NTS.						

TRAVEL FOOD SERVICES

Eq.No :- CK-03

JUICE DISPENSER
(UGOLININ-DELUX 12/2)

Over All Size:- 360 x 480 x 570Ht,

Qty:- 1 No.

DRAWING

Dimensons Are In MM



ARCTIC DELUXE

	← cm	↑ cm	↘ cm	Kg	Kg	ℓ
Arctic Deluxe 12/1	18	57	47	17	19	12
Arctic Deluxe 12/2	36	57	47	23	26	24
Arctic Deluxe 12/3	54	57	47	37	40	36
Arctic Deluxe 12/4	72	57	47	50	55	48
Arctic Deluxe 20/1	18	67	47	18	20	20
Arctic Deluxe 20/2	36	67	47	26	29	40
Arctic Deluxe 20/3	54	67	47	42	45	60
Arctic Deluxe 20/4	72	67	47	53	56	80



Arctic Deluxe 12 / 2 "AA"



Arctic Deluxe 20 / 2 "P"

White line



20 / 1 20 / 2 20 / 3 20 / 4



agitatore ("AA")
stirring paddle ("AA")
mélangeur ("AA")
Rührwerk ("AA")
agitador ("AA")



pompa a fontana ("P")
fountain pump ("P")
pompe à effet fontaine ("P")
Fontänenpumpe ("P")
bomba de fuente ("P")



rubinetto a gravità
gravity tap
robinet à gravité
Schwerkraft-Hahn
grifo por gravedad

TITLE :	JUICE DISPENSER (UGOLININ-DELUX 12/2)	REV. NO :	---	DESIGN BY	Sign
		DATE :	10-09-2024	DWN. BY : FAHEEM	
		SCALE :	N.T.S.	CHKD BY: VD	
PROJECT :	CURRY KITCHEN @ FRENCH LOAF - CHENNAI			APRVD BY:	



TRAVEL FOOD SERVICES

Eq.No :- CK-05

SS 2 CONTAINER HOT BAIN MARIE 1/1x150Deep GN PAN WITH EXTERNAL PANEL & REMOVABLE PATTI FOR ADJUSTABLE GN PAN

Over All Size:- 750 x 650 x 850

Qty:- 1 No.

DRAWING

Dimensons Are In MM

3KW HEATER & CUTOFF VALVE FIXED IN TANK

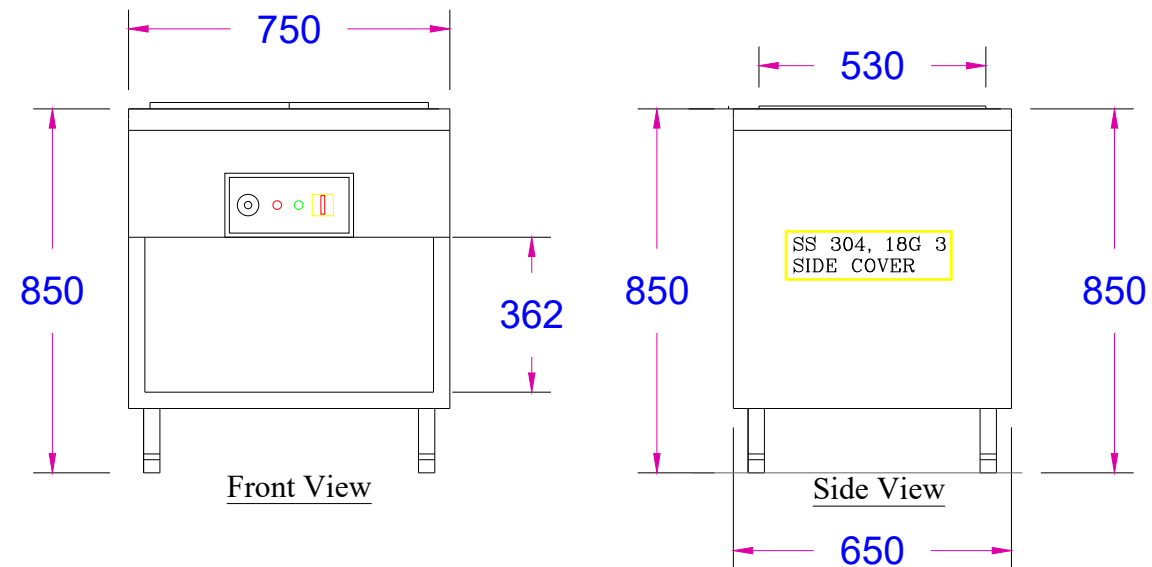
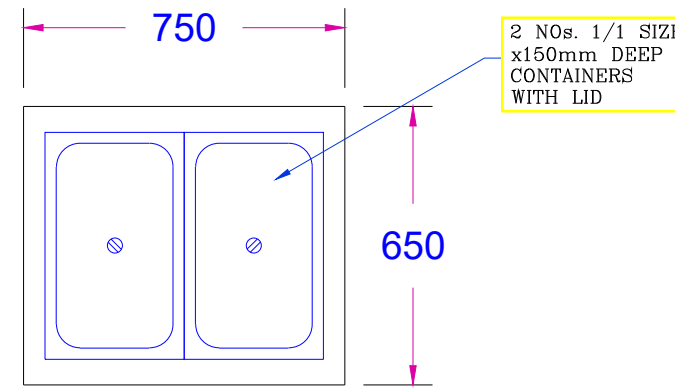
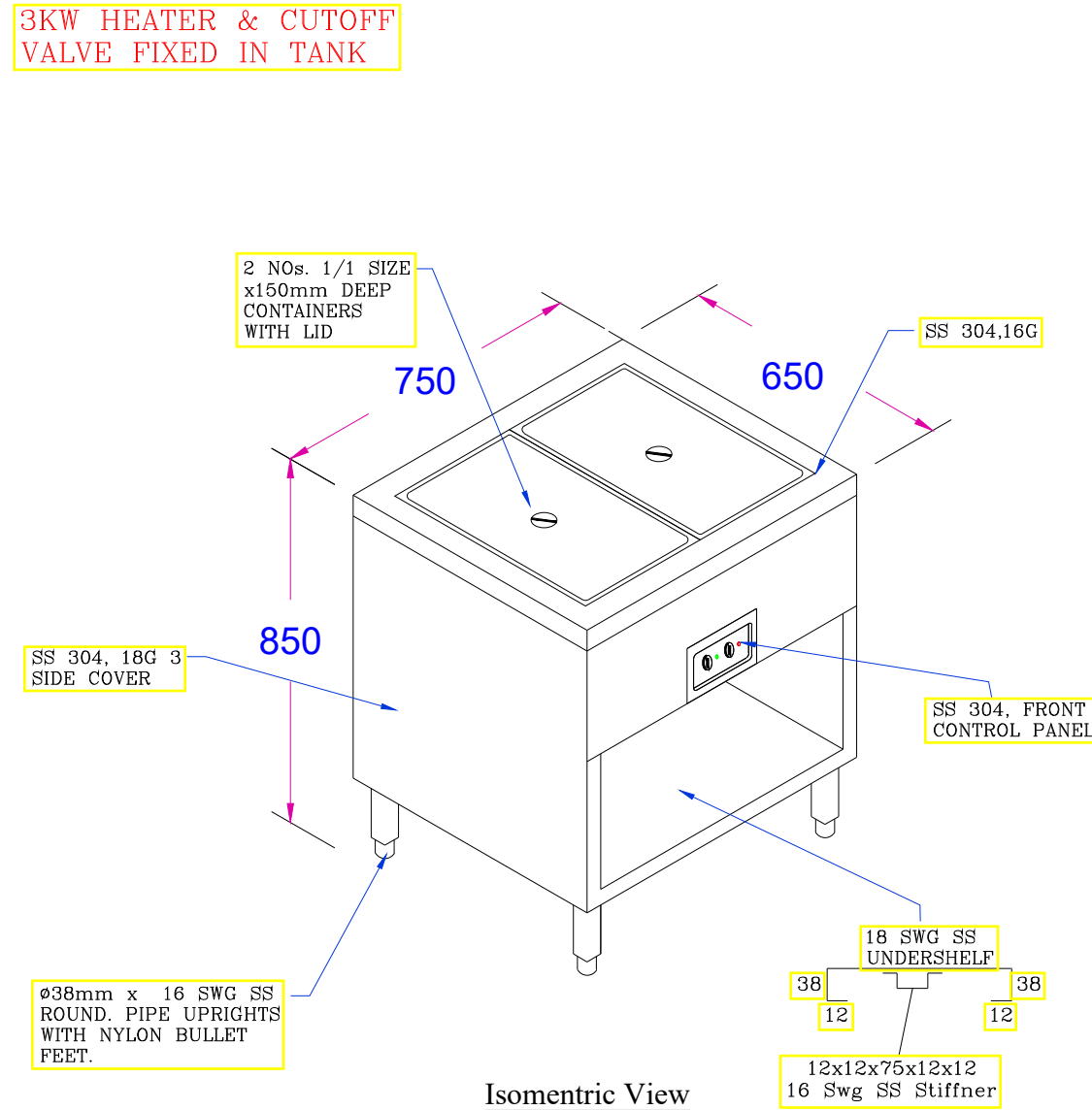

TITLE :	SS 2 CONTAINER HOT BAIN MARIE 1/1x150Deep GN PAN WITH EXTERNAL PANEL & REMOVABLE PATTI FOR ADJUSTABLE GN PAN	REV. NO :	---	DESIGN BY	Sign
		DATE :	10-09-2024	DWN. BY : FAHEEM	
		SCALE :	N.T.S.	CHKD BY: VD	
PROJECT :	CURRY KITCHEN @ FRENCH LOAF - CHENNAI			APRVD BY:	



TRAVEL FOOD SERVICES

Eq.No :-CK-06

SS 3 CONTAINER HOT BAIN MARIE 1/1x150Deep GN PAN WITH EXTERNAL PANEL & REMOVABLE PATTI FOR ADJUSTABLE GN PAN

Over All Size:- 1075 x 650 x 850

Qty:- 1 No.

DRAWING

Dimensons Are In MM

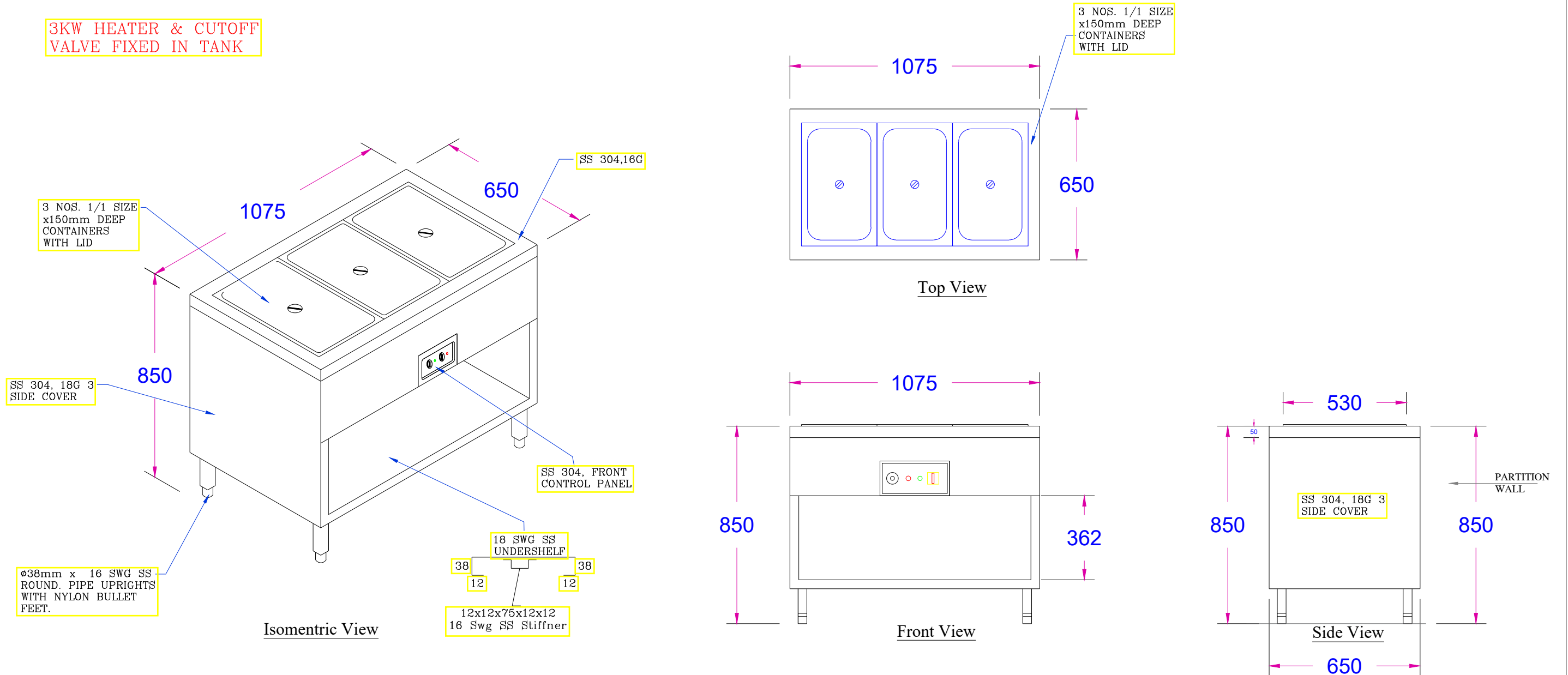

TITLE :	SS 3 CONTAINER HOT BAIN MARIE 1/1x150Deep GN PAN WITH EXTERNAL PANEL & REMOVABLE PATTI FOR ADJUSTABLE GN PAN	REV. NO :	---	DESIGN BY	Sign
		DATE :	10-09-2024	DWN. BY : FAHEEM	
		SCALE :	N.T.S.	CHKD BY: VD	
PROJECT :	CURRY KITCHEN @ FRENCH LOAF - CHENNAI			APRVD BY:	



TRAVEL FOOD SERVICES

Eq.No :- CK-07

SS COLD BAIN MARIE WITH 1 NO, GN PAN 1/1 x 150mm DEEP &
REMOVABLE PATTI FOR ADJUSTABLE GN PAN

Over All Size:- 450 x 650 x 850

Qty:- 1 No.

DRAWING

Dimensons Are In MM

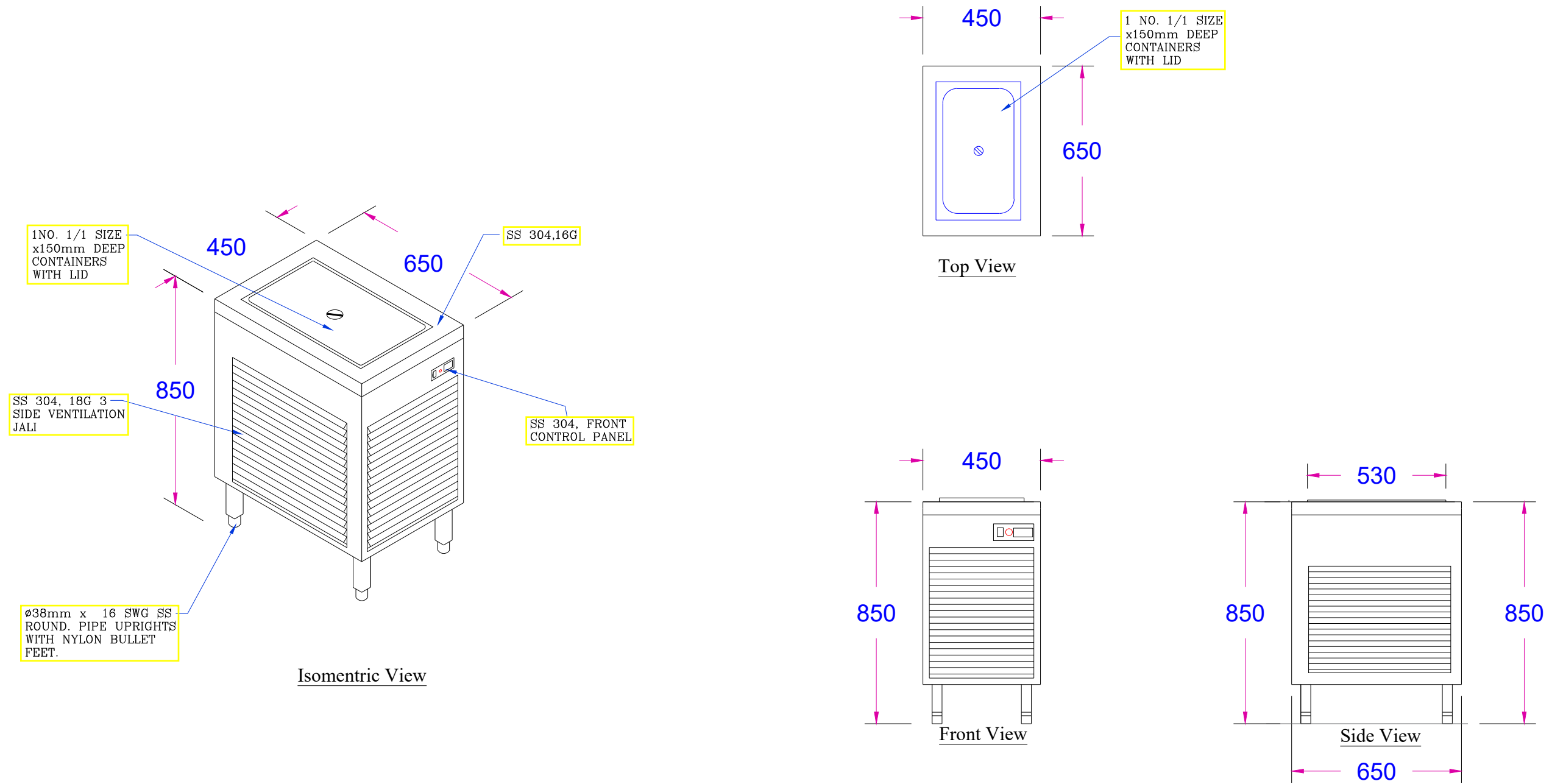

TITLE :	SS COLD BAIN MARIE WITH 1 NO, GN PAN 1/1 x 150mm DEEP & REMOVABLE PATTI FOR ADJUSTABLE GN PAN	REV. NO :	---	DESIGN BY	Sign
		DATE :	10-09-2024	DWN. BY : FAHEEM	
		SCALE :	N.T.S.	CHKD BY: VD	
PROJECT :	CURRY KITCHEN @ FRENCH LOAF - CHENNAI			APRVD BY:	



TRAVEL FOOD SERVICES

Eq.No :- CK-09

TABLE TOP MOMOs STEAMER
(SR-WA18H-SS)

Over All Size:- 256 x 256 x 360Ht.

Qty:- 2 Nos.

DRAWING

Dimensons Are In MM



TITLE :	TABLE TOP MOMOs STEAMER (SR-WA18H-SS)	REV. NO :	---	DESIGN BY	Sign	
		DATE :	10-09-2024	DWN. BY : FAHEEM		
PROJECT :	CURRY KITCHEN @ FRENCH LOAF - CHENNAI	SCALE :	N.T.S.	CHKD BY: VD		
				APRVD BY:		

TRAVEL FOOD SERVICES

Eq.No :- CK-10

TABLE TOP FOOD WARMER
(MODEL NO:- MIR11)

Over All Size:- 335 x 615 x 420

Qty:- 1 No.

DRAWING

Dimensons Are In MM



Product name: Food warmer

Model : MIR11

Brand : Berjaya

Voltage: 220-240 / 1 / 50Hz

Power (W): 510

Device size (mm) : 615 x 335 x 420

Packing size (mm) : 657 x 380 x 257

Food tray size: FP1/1-2.5

Device weight (Kg) : 6.5

TITLE :	TABLE TOP FOOD WARMER (MODEL NO:- MIR11)	REV. NO :	---	DESIGN BY	Sign	
		DATE :	10-09-2024	DWN. BY : FAHEEM		
PROJECT :	CURRY KITCHEN @ FRENCH LOAF - CHENNAI	SCALE :	N.T.S.	CHKD BY: VD		
				APRVD BY:		

TRAVEL FOOD SERVICES

Eq.No :- CK-11

SS CIVIL COUNTER
FITTED SINK

Over All Size:- 400 x 400 x 150

Qty:- 1 No.

DRAWING

Dimensons Are In MM

SS 304 ,16 SWG SS SINK
OF SIZE:400x400x150HT.
WITH ϕ 38 BSP DRAIN
COUPLING

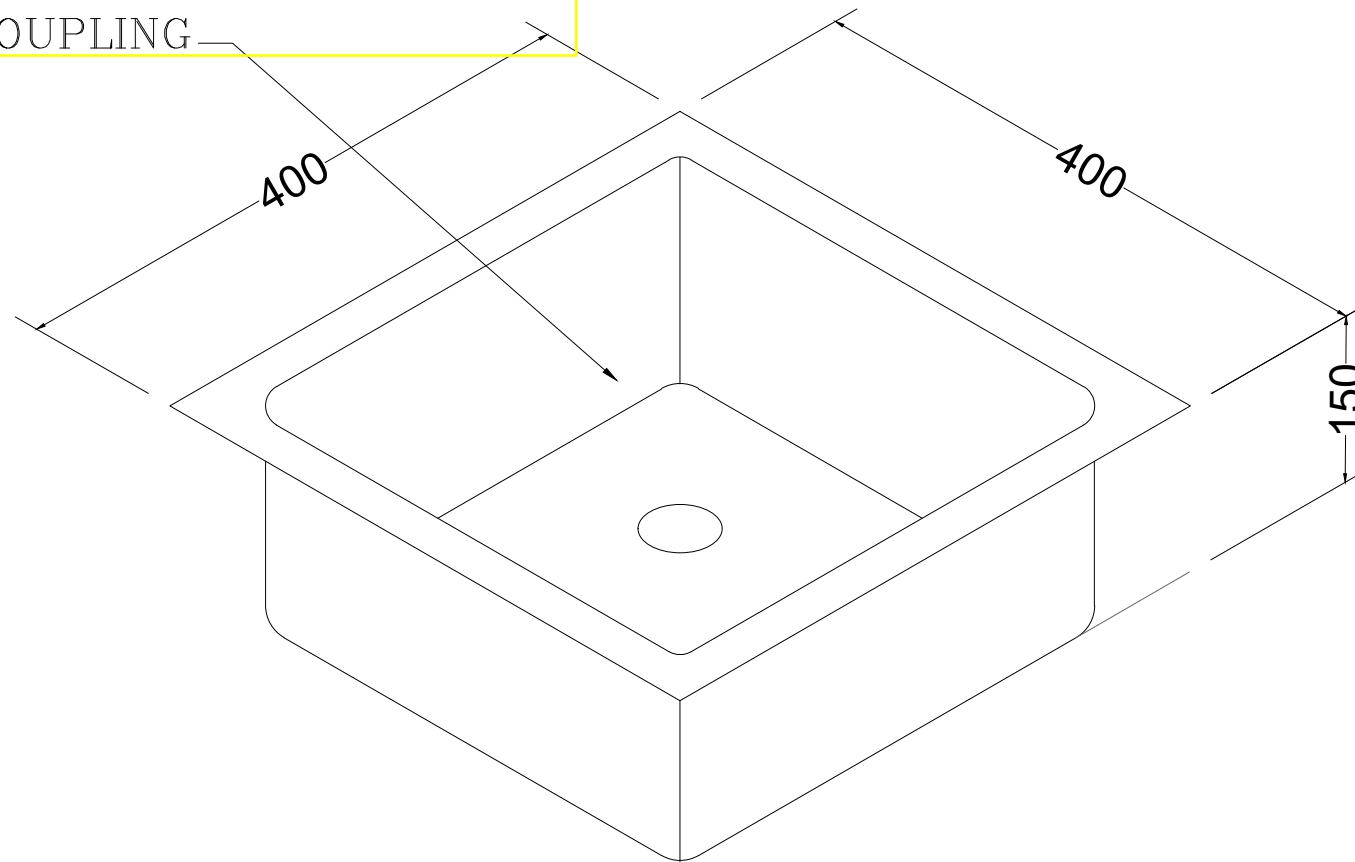

Front View

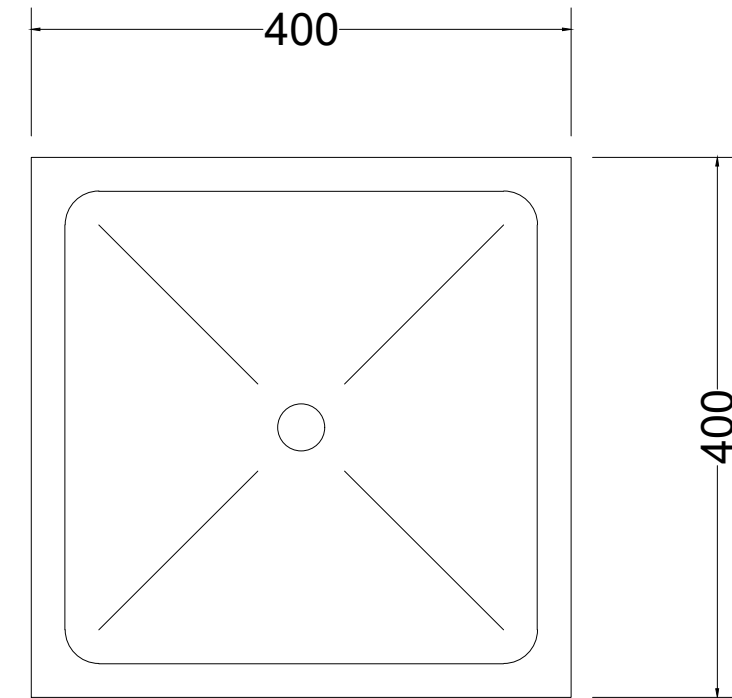

Top View

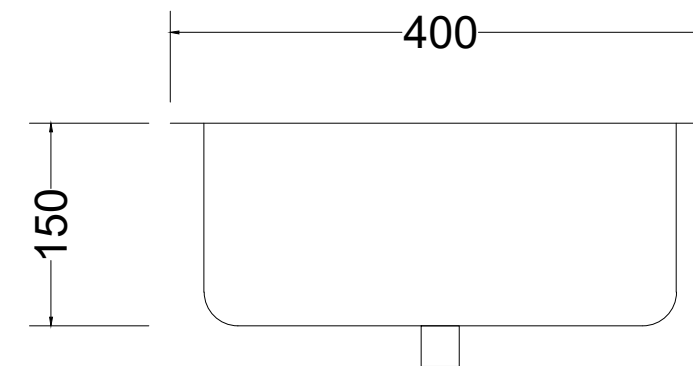

Front View

TITLE :	SS CIVIL COUNTER FITTED SINK	REV. NO :	---	DESIGN BY	Sign
		DATE :	10-09-2024	DWN. BY : FAHEEM	
PROJECT :	CURRY KITCHEN @ FRENCH LOAF - CHENNAI	SCALE :	N.T.S.	CHKD BY: VD	
				APRVD BY:	



TRAVEL FOOD SERVICES

Eq.No :- CK-12

GREASE TRAP (NUGREEN-NGT-14)

Over All Size:- 337 x404 x 303

Qty:- 1 Nos.

DRAWING

Dimensions Are In MM

NUGREEN
Building Technologies Pvt. Ltd.

SS Grease Trap

Are you one of these facilities!

Have you seen pipes that look likethis?

NUGREEN
Building Technologies Pvt. Ltd.

Nugreen Grease separator " NGT 8/14/20/30/40/50/70/100 "									
Grease Trap SS 304	Inlet/Outlet (mm)	Holding Capacity (Litre)	Flow (Lit/min)	Bottom to Centre of Inlet (A) (mm)	Bottom to Centre of outlet (B) (mm)	Width (mm)	Length (mm)	Height (mm)	Grease capacity (kg)
NGT 8	50	15.9	18	177	177	262	355	280	3
NGT 14	50	25.5	28	203	193	337	404	303	7
NGT 20	60	34.3	38	203	193	362	503	303	9
NGT 30	75	47.5	57	256	246	400	512	343	13
NGT 40	87.5	57.5	75.5	287	277	400	562	375	18
NGT 50	87.5	72	95	300	290	437	612	412	23
NGT 70	87.5	104	132	353	343	450	712	481	32
NGT 100	112	156	189	406	396	556	762	537	45

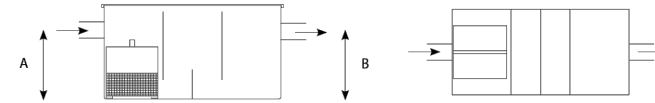

Description:

- For free standing installation in frost free areas, with integrated sludge trap, SS quick release odour-tight covers.
- Inlet and outlet varies from Ø 50mm to Ø 112mm.
- Sludge trap content: _____ Litre.
- Grease trap content: _____ Litre.

Manufacturer:

Nugreen Building Technologies Pvt Ltd, New Delhi

Application:

- Especially suitable in areas in which limited amounts of fat and sludge occur, and above all wherever vegetable oil is used.
- Grease separator system should be emptied on a daily basis.

Nugreen-advantages:

- System made form SS 304 '2 mm' thick for corrosion free compact structure.
- Sturdy and long lasting structure.
- Fast removal of cover for easy maintenance.
- Inlet meets all on-site requirements.
- Innovative & easy to remove SS 304 sieve basket for sludge collection.

NUGREEN

Nugreen Building Technologies (P) Ltd.
C - 6, Basement, Unit D, Rajouri Garden
New Delhi - 110027
Tel : +91 11 45715964
Email: info@nugreen.co.in
Website: www.nugreen.co.in



TITLE :	GREASE TRAP (NUGREEN-NGT-14)	REV. NO :	---	DESIGN BY	Sign	
		DATE :	10-09-2024	DWN. BY : FAHEEM		
PROJECT :	CURRY KITCHEN @ FRENCH LOAF - CHENNAI	SCALE :	N.T.S.	CHKD BY: VD		
				APRVD BY:		

TRAVEL FOOD SERVICES

Eq.No :- CK-13

MICROWAVE OVEN WITH WALL MOUNTED STAND (CELFROST-CMO25)

Over All Size:- 511 x 432 x 311

Qty:- 1 Nos.

DRAWING

Dimensions Are In MM

CMO 34 DD
Celfrost
COMMERCIAL



Double Magnetron

Heavy Volume Commercial Microwave Oven

Power Output

- 1800 watts of power

Boost heats & re-thermfoods in seconds

Features

- Large capacity (1.2 cu.ft / 34 L), accommodates a 14" (356 mm) platter.
- Able to withstand the demands of the Commercial Food Service environment with stainless steel cabinet and oven cavity.

Applications

- Convenience Stores
- Dessert stations
- Nurses stations
- Coffee shops
- Teachers/Staff lounge
- Vending
- Cloud Kitchens
- Dark Kitchen

CMO 25
Celfrost
COMMERCIAL



Easy to Use



- See-through door and lighted interior for monitoring without opening the door
- 25 liter capacity accommodates a 305mm (12") platter, pre-packaged foods and single servings
- Stainless steel cabinet and oven cavity.
- Bottom Energy Feed.
- Time entry option and X2 multiple quantity pad provide flexible operation.
- EZ Grab'n Go door handle for reliable use, no moving parts.
- User-friendly touch control pads and Electronic dial timer with braille navigation

CMO 25 is ideal for...

Applications

- Convenience Stores
- Dessert stations
- Nurses stations
- Coffee shops
- Teachers/Staff lounge
- Vending

Boost heats & re-thermfoods in seconds

Why Commercial Microwave Ovens

You put your business at risk when you use a residential microwave in a food service environment.

Advantages of Commercial Microwave oven:

- Higher standards for added safety
- Peace of Mind
- Built with heavy duty power cords, commercial quality relays
- Heavy Duty Doors tested for many openings
- More powerful for faster heating and better quality results
- Consumes less energy than a Residential Microwave Oven
- No turntable, No hassle
- Control panels are designed for quick and easy operation
- Braille and icons accessible to non-english readers and the visually impaired
- Programmable touch panel, easy to use
- Residential microwaves have smaller keypads, cannot be programmed into multiple stages

	Commercial	Residential
Typical usage	50-250/Day	3-5/Day
Used by	Many Employees	1-2 people
Food type	Variety of menu items	Limited items
Typical kitchen	Variable temp	Controlled temp

Key Pads		Key Pads	
Commercial	Domestic	Commercial	Domestic
Easy to Use	Can't be Programmed	No Turn Table	Turn Table Chance to break by user
		Hassle Free Operation	Waste of Space

Model	Capacity (in Ltr.)	Dimensions (WxDxH mm)	Cavity Dimensions (WxDxH mm)	Microwave Cooking Power (W)	Power Label	No. of Cooking Stage	Programmable Menu Setting	No. of Magnetrons	Maximum Cooking Time (min)	Power Consumption (W)	Volts/Hz
RCS 511 TSI	34	559 x 483 x 352	368 x 381 x 216	1100	5	4	100	1	60	1600	220V/50Hz
RMS 510 TSLA	23	512 x 403 x 310	330 x 330 x 197	1000	5	3	20	1	30	1500	220V/50Hz
CMO 25	25	511 x 432 x 311	327 x 346 x 200	1100	5	1	9	1	60	1550	220V/50Hz
CMO 34 DD	34	574 x 528 x 368	360 x 409 x 225	1800	5	3	99	2	60	2800	220V/50Hz

Commercial Food Service Equipment with World Leading Technologies



MIDDLEBY CELFROST

Middleby Celfrost Innovations (P) Ltd.

Corp. Office : Unit Nos. SF-713 — 716, 7th Floor, JMD Megapolis, Sohna Road, Sector 48, Gurugram - 122 018, Haryana, India.
Tel. : +91 124 482 8500, Fax : +91 124 427 9663, E-mail : corp@middlebycelfrost.com, Web : www.middlebycelfrost.com

Toll Free Customer Service No.: 1800-102-1980 • service.india@middlebycelfrost.com

ONE PARTNER. ONE TEAM. MANY SOLUTIONS.



For sales related queries :-
Call: +91 124 4828500 • Email: sales@middlebycelfrost.com

TITLE :	MICROWAVE OVEN WITH WALL MOUNTED STAND (CELFROST-CMO25)	REV. NO :	---	DESIGN BY	Sign
		DATE :	10-09-2024	DWN. BY : FAHEEM	
PROJECT :	CURRY KITCHEN @ FRENCH LOAF - CHENNAI	SCALE :	N.T.S.	CHKD BY: VD	
				APRVD BY:	



TRAVEL FOOD SERVICES

Eq.No :- CK-15

TABLE TOP INDUCTION PLATE (STELLA-TS-3501)

Over All Size:- 350 x 410 x 95

Qty:- 2 Nos.

DRAWING

Dimensons Are In MM



TS-3501 Table-Top Single

SHORT DESCRIPTION:

- Function
- Smart design, table top design
- Commercial model
- SIZE: 350*410*95mm
- 3500W
- Chinese kanger glass
- 20 Power Setting
- Digital Timer
- Safety Lock
- Stainless steel housing
- Automatic Shut-Off

[Send email to us](#)

● TS-3501



Technical Specifications

Size	350*410*95mm
Power	3500W
Weight	5.5 kg
Dim. (H/W/D)	350*410*95mm
Installation (H/W/D)	Table top
Housing	stainless steel
Article-No.	TS-3501
EAN-Code	

Product Features

- DURABLE & EASY TO CLEAN:** Reliability and durability are guaranteed by the stainless steel construction. has a back turret and a 7-blade fan to burn on the glass cooktop because there is no open flame or heating element, making cleanup simple—just wipe with a wet cloth.
- As cookware on induction stoves is what generates heat, it's important to select items with magnetic bottoms that have a minimum diameter
- SENSOR TOUCH PANEL WITH LED SCREEN:** The sensor touch panel is touch-sensitive and simple to use.
- Constructed to work consistently and robustly in commercial and professional environments, including eateries, commercial kitchens, and oth
- Cooking areas**
There is only one cooking zone on this stove.

TITLE :	TABLE TOP INDUCTION PLATE (STELLA-TS-3501)	REV. NO :	---	DESIGN BY	Sign	 <p>Travel Food Services</p>
		DATE :	10-09-2024	DWN. BY : FAHEEM		
PROJECT :	CURRY KITCHEN @ FRENCH LOAF - CHENNAI	SCALE :	N.T.S.	CHKD BY: VD		
				APRVD BY:		

TRAVEL FOOD SERVICES

Eq.No :- CK-16

2 DOOR U/C CHILLER. WITH LOCKABLE CASTOR WHEELS (2 Nos.WITH BREAK INFRONT & 2 Nos. WITHOUT BREAK) & HEATING ELEMENT FOR DRAIN .

Over All Size:- 1365 x 700 x 850(BLUE STAR-UC2100GC)

Qty:- 1 No.

DRAWING

Dimensions Are In MM





UNDERCOUNTER CHILLERS AND FREEZERS

High performance comes with a heavy-duty build. Blue Star's range of Undercounter Chillers and Freezers is ideal for storing pre-mixes and preparation materials. This range comes with an auto door-close mechanism and uses food grade stainless steel to keep food fresh.

These Undercounter Chillers and Freezers provide precise temperatures, are designed aesthetically and built for heavy-duty use.

Also available in the Undercounters range are Pizza Tables, Saladette Range, Sandwich Stations and Chilled Topping Units.

FEATURES

-  Tropicalised for high ambient temperatures
-  Eco-friendly refrigerant
-  Food grade stainless steel unit
-  Odourless operation due to continuous air circulation
-  Uniform cooling by forced air circulation
-  Self-closing doors





Technical Specifications

Description	Undercounter Chillers			
	UC2100GP	UC3100GP	UC2100GC	UC3100GC
Capacity (Ltrs)	260	400	260	400
Temperature Range	0° ~ - + 12°C	0° ~ - + 12°C	0° ~ - + 12°C	0° ~ - + 12°C
No. of Doors	2	4	2	3
Type of Doors (Int/Ext)	SS-304/201	SS-304/201	SS-201/201	SS-201/201
Shelves Qty	2	3	2	3
Gn Pan	GN2/1	GN2/1	GN2/1	GN2/1
Refrigerant Gas (Type/Charge)	R290/50g	R290/50g	R290/50g	R290/50g
Voltage supply & Frequency (V-Hz)	220-240V/50Hz	220-240V/50Hz	220-240V/50Hz	220-240V/50Hz
Max Input Power	255W	255W	255W	255W
Current Amps	1.3	3.3	1.3	3.3
Defrost	Automatic	Automatic	Automatic	Automatic
Thermostat	Digital	Digital	Digital	Digital
External Dimension (W x D X H) mm	1365 x 700 x 850	1805 x 700 x 850	1365 x 700 x 850	1805 x 700 x 850
Net Weight (kg)	96	116	96	116
Gross Weight (kg)	115	142	115	142

TITLE :	2 DOOR U/C CHILLER. WITH LOCKABLE CASTOR WHEELS (2 Nos.WITH BREAK INFRONT & 2 Nos. WITHOUT BREAK) & HEATING ELEMENT FOR DRAIN .	REV. NO :	---	DESIGN BY	Sign
		DATE :	10-09-2024	DWN. BY :	FAHEEM
		SCALE :	N.T.S.	CHKD BY:	VD
PROJECT :	CURRY KITCHEN @ FRENCH LOAF - CHENNAI	APRVD BY:			



TRAVEL FOOD SERVICES

Eq.No :- CK-17

SPEED OVEN (MERRYCHEF-E1S)

Over All Size:- 400 x 550 x 600

Qty:- 1 No.

DRAWING

Dimensions Are In MM



Develop your menu

The Merrychef **eikon® e1s** is one of the most compact high speed ovens on the market, designed for small businesses looking to add a hot food option to their operation or improve throughput. A single counter-top appliance, styled for front-of-house and programmed to produce high quality results for every order, with a simple touch of an icon. Ideal to rapidly cook, toast and bake a wide choice of dishes from both fresh and frozen foods.

High speed
Reduces waiting time, by cooking up to 10x faster than a conventional oven.

Versatile
Saves space; just one piece of equipment to cook a wide variety of food.



Easy to install
No installation costs, simply plug and play via a single phase 13A (UK), 16A (EU) plug.

Efficient
Excellent return on investment with low power consumption; only uses less than 0.7 kWh on standby. Saves money when not in use.

Expanding your opportunities

www.merrychef.com

eikon® e1s

eikon® e1s

Perfect for small spaces

A compact, stylish counter-top appliance designed to easily fit into small spaces and provide an invaluable resource for food providers. Superior functionality with ventless as standard, means that no extraction hood is needed. This together with an innovative cooling system keeping all exterior walls cool-to-touch, makes it perfect for small spaces, tight corners and for sitting directly alongside other appliances like coffee machines.

Precision Technology

The finely tuned combination of three heating technologies: convection (2200W), tuned impingement and microwave (800W) makes the heat level consistent ensuring even, high quality, repeatable results 10x faster than a conventional oven.

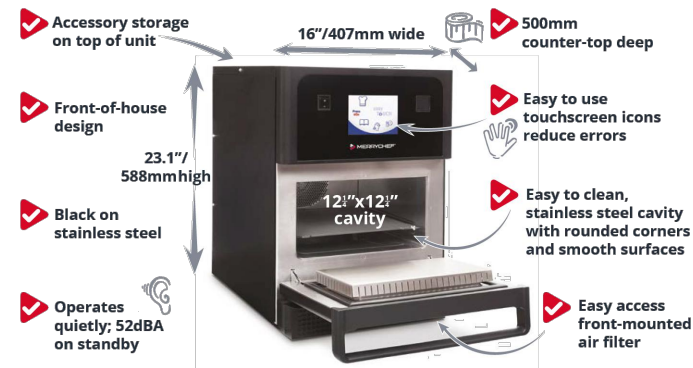

Press & Go

The Merrychef eikon® e1s arrives pre-programmed with menus ranging from paninis and French Fries to pies. Creating your own couldn't be simpler with the easy to follow icon based instructions, or better still the Merrychef Ready Recipe tool allows you to download a wide range of recipes straight to the oven via a USB.



The easytouch® icons allow low-skilled staff to produce professional results whilst minimising training time and overcoming any language barriers.

All cook times may vary depending on food quality and portion size.

Accessories

To get you started, every order includes the following dishwasher-compatible items:



The true versatility of the Merrychef eikon® e1s is realised through our unique Signature range of accessories that are available; from egg moulds to soup bowls.

View the full range at merrychef.com/products/accessories

©2019 Welbilt Inc. All rights reserved. Merrychef_eikon®_e1s_UK_06/19



For further details on where to buy, how to service and for our flagship culinary support please visit www.merrychef.com

Customer satisfaction

Your satisfaction with our products is of paramount importance to us. With almost 70 years of experience you can be assured of a high quality, precision built appliance. The Merrychef eikon® e1s has a built-in self-diagnostic system with full warranty and service support for peace of mind.

TITLE :	SPEED OVEN (MERRYCHEF-E1S)	REV. NO :	---	DESIGN BY	Sign
		DATE :	10-09-2024	DWN. BY : FAHEEM	
		SCALE :	N.T.S.	CHKD BY: VD	
PROJECT :	CURRY KITCHEN @ FRENCH LOAF - CHENNAI			APRVD BY:	



Travel Food Services

TRAVEL FOOD SERVICES

Eq.No :- CK-18

TEA & COFFE MAKER
MACHINE- GEMINI

Over All Size:- 600 x 270 x 470Ht.

Qty:- 1 No.

DRAWING

Dimensons Are In MM



★★★★★ (1 customer review)

Availability: In Stock

Brand: Gemini

Product Code: Filter Coffee Maker

HIGHLIGHTS

Type	Filter Coffee Maker
Beverage Options	Six
Brand	Gemini
Dimension	600 mm * 240 mm * 470 mm
Capacity	110 - 130 Cups
Power Consumption	230 V A/c
Control System	Semi Automatic Controller
Decoction Output	20 Minutes

TITLE :	TEA & COFFE MAKER MACHINE- GEMINI	REV. NO :	---	DESIGN BY	Sign	
		DATE :	10-09-2024	DWN. BY : FAHEEM		
PROJECT :	CURRY KITCHEN @ FRENCH LOAF - CHENNAI	SCALE :	N.T.S.	CHKD BY: VD		
				APRVD BY:		

TRAVEL FOOD SERVICES

Eq.No :- CK-19

VISI COOLER (BLUESTAR-SC300F)

Over All Size:- 576 x 686 x 1454Ht.

Qty:- 1 No.

DRAWING

Dimensions Are In MM



2021_MAR_BLUE STAR LTD_CORP_11495902_MG_A4_VISICOOLER_LEAFLET

Blue Star presents a range of Super Coolers that are high on performance and perfect for heavy-duty applications. Equipped with a ventilated cooling mechanism that ensures both fast and uniform cooling, these visi coolers make sure every shelf and every corner is just as cold as the other.

-  Pre-coated metallic inner and outer cabinet for durability and enhanced cooling
-  Tropicalised for harsh Indian weather conditions
-  Castor wheels for easy movement
-  Corrosion-free aluminium door frame
-  LED lighting for better visibility
-  Self-closing doors
-  Adjustable shelves
-  Locks in all models
-  Eco-friendly refrigerant (R134a)



Technical Specifications:

Description	Units	SC300F	SC375F	SC500F	SC650F	SC1000F
Gross Capacity	L	285	358	448	595	947
Temperature		+2°C to +10°C	+2°C to +10°C	+2°C to +10°C	+2°C to +10°C	+2°C to +10°C
Power Supply		220V/50Hz/1Ph	220V/50Hz/1Ph	220V/50Hz/1Ph	220V/50Hz/1Ph	220V/50Hz/1Ph
Refrigerant		R134a	R134a	R134a	R134a	R134a
No. of Doors	Nos.	1	1	1	2	2
Provision for Locking		Available	Available	Available	Available	Available
Overall Dimensions (including hinge, castor etc.)	mm	576x686x1454	576x686x1724	576x686x2055	739x686x2063	1025x781x2030
Net Weight	kg	71	81	98	108	171
No. of Shelves	Nos.	Wire /4	Wire /5	Wire /5	Wire /5	Wire /10



For more information, please contact BLUE STAR LIMITED - Chennai: XRM Plaza, No. 2, Harrington Road, Chennai - 600031. Tel: (044) 4244000 - Gurgaon: 6th Floor, Vaidya Anand, Golf Course Road, Sector 53, Gurgaon - 122002 (Haryana) Tel: (0120) 4264000 - Kolkata: 1st Floor, Eco Centre Business Tower, Salt Lake, Bidhannagar, Kolkata - 700091. Tel: (033) 4881 5400 - Mumbai: Blue Star House, 9/A Chhatrapati Shivaji Maharaj, Salt Lake, Mumbai - 400072. Tel: (022) 6668000 - Ahmedabad: Tel: (079) 40234000 - Bangalore: Tel: (080) 4188 4000 - Bhubaneswar: Tel: (0674) 2527400/2574000 - Chandigarh: Tel: (0172) 5024000 - Chennai: Tel: (0120) 2821 6000 - Goa: Tel: (0832) 2438171/2427287 - Guwahati: Tel: (0361) 2468496 - Indore: Tel: (0731) 4001211/4001311 - Jaipur: Tel: (0141) 331 3000 - Jammu: Tel: (0191) 222 1530 - Kochi: Tel: (0484) 4499000 - Ludhiana: (Punjab) Tel: (0181) 506 4000 - Lucknow: Tel: (0522) 4034000 - Nagpur: Tel: (0712) 2249000/2430000 - New Delhi: Tel: (011) 4149 4000 - Pune: Tel: (020) 41044000/24167200 - Raipur: Tel: (0771) 428 0000 - Hyderabad: Tel: (040) 4400 4000 - Thane: Tel: (022) 0715 4000 - Thiruvananthapuram: Tel: (0471) 245000 - Vadodra: Tel: (0220) 6614000/2330122 - Visakhapatnam: Tel: (0891) 2746400/2746433 - Vijayawada: Tel: (0866) 2464004.

TITLE :	VISI COOLER (BLUESTAR-SC300F)	REV. NO :	---	DESIGN BY	Sign
		DATE :	10-09-2024	DWN. BY : FAHEEM	
		SCALE :	N.T.S.	CHKD BY: VD	
PROJECT :	CURRY KITCHEN @ FRENCH LOAF - CHENNAI			APRVD BY:	

